

PLAN
N.T.S.

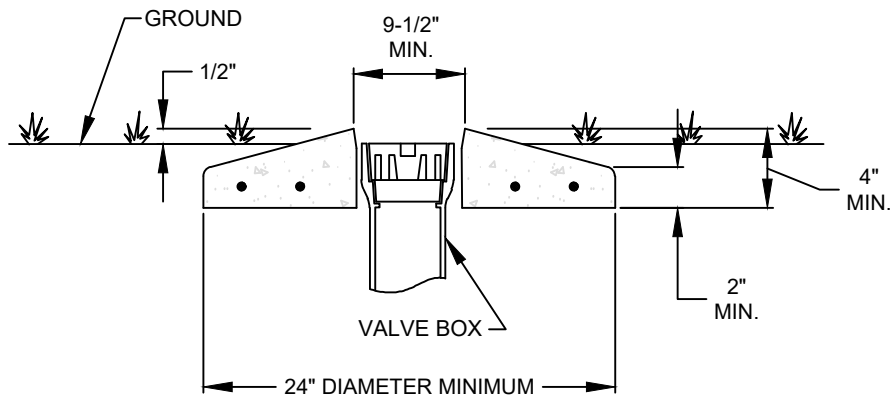

SECTION A-A
N.T.S.

NOTES:

1. CONCRETE PROTECTOR RING SHALL BE 2500PSI PRECAST REINFORCED CONCRETE.
2. VALVE BOX SHALL BE AT GRADE WITH PROTECTOR RING EXTENDING 1/2" ABOVE GRADE.
3. SEE GATE VALVE AND BOX DETAIL.
4. VALVE BOX PROTECTOR RINGS SHALL BE INSTALLED AROUND VALVE BOX IN UNPAVED NON-TRAFFIC AREAS AND SHALL NOT CREATE A HINDRANCE TO MOWING OPERATIONS.

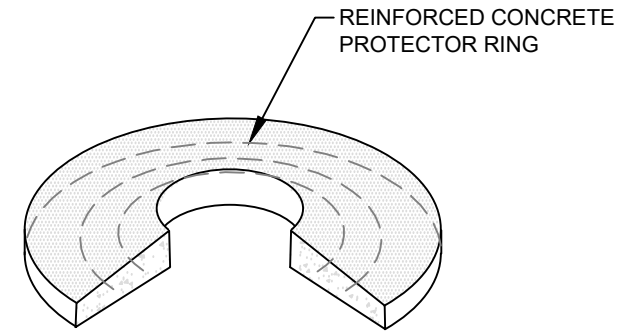

CUT AWAY VIEW
N.T.S.

VALVE BOX PROTECTOR RING
N.T.S.

FAYETTEVILLE
PUBLIC WORKS COMMISSION
FAYETTEVILLE, N.C.



NO.	DATE	REVISION

SHEET NO.
1 OF 1

DWG. NO. **W.8**

DWG. BY: FAYPWC

DATE: JAN. 01, 2025

APPROVED BY: K.A.H.

WATER RESOURCES
ENGINEERING DEPARTMENT