



**TECHNICAL SPECIFICATIONS**

**VOLUME II**

**PWC2324000**

**PHASE V ANNEXATION PROJECT XI AREA 25 LAKE  
RIM ESTATES**

**ISSUED FOR BID**

**JULY 2023**

**Fayetteville Public Works Commission  
Water Resources Engineering  
PWC Administrative Building  
955 Old Wilmington Road  
Fayetteville, NC 28301**

**Moorman, Kizer & Reitzel,  
Inc. 115 Broadfoot Avenue  
Fayetteville, NC 28305  
(910) 484-5191  
NC License F-0106**

## TABLE OF CONTENTS

### DIVISION 2 – SITEWORK

02110 Site Clearing	02110 - 1 to 02110 - 2
02111 Site Clearing for PWC Utilities	02111 – 1 to
02211 Grading, Utilities	02211 - 1 to 02211 - 3
02222 Excavation and Backfilling for Utility Systems	02222 - 1 to 02222 - 5
02272 Erosion Control - General Provisions	02272 - 1 to 02272 - 2
02273 Temporary Silt Fence	02273 - 1 to 02273 - 1
02274 Gravel Construction Entrance/Exit	02274 - 1 to 02274 - 1
02275 Block and Gravel Inlet Protection	02275 - 1 to 02275 - 1
02301 Boring and Jacking	02301 - 1 to 02301 - 3
02302 HDD	02302 – 1 to 02302 - 8
02500 Traffic Control	02500 - 1 to 02500 - 5
02505 Adjustment of Existing Structures	02505 - 1 to 02505 - 2
02573 Permanent Pavement Patch	02573 - 1 to 02573 - 2
02574 Temporary Pavement Patch (Type I-19.0C)	02574 - 1 to 02574 - 2
02575 Driveway Replacement	02575 - 1 to 02575 - 3
02584 Roadway and Parking Lot Marking	02584 - 1 to 02584 - 1
02660 Water Distribution	02660 - 1 to 02660 - 13
02662 Fire Hydrant Painting	02662 - 1 to 02662 - 2
02730 Sanitary Sewer System	02730 - 1 to 02730 - 13
02732 Sewage Force Mains	02732 - 1 to 02732 - 8
02736 HDPE	02736 – 1 to 02736 - 4
02831 Chain Link Fencing	02831 - 1 to 02831- 3
02931 Lawns and Grasses (Sodding)	02931 - 1 to 02931 - 5
02933 Lawns and Grasses (Seeding)	02933 - 1 to 02933 - 4
02934 Seeding Wetlands	02934 - 1 to 02934 - 3
03301 Concrete Construction (Utility)	03301 - 1 to 03301 - 5
09801 Anti-Microbial Additive	09801 - 1 to 09801 - 2
09802 Special Coatings (Ceramic Epoxy)	09802 - 1 to 09802 - 2
09804 Special Coatings (Epoxy Lining Ductile Iron Pipe and Fittings)	09804 - 1 to 09804 - 5

### APPENDICES

Appendix A – Letter of Approval
Appendix B – Permit
Appendix C – Report of Subsurface Exploration and Geotechnical Eval
Appendix D – Erosion and Sedimentation Control Narrative
Appendix E – Certificate of Coverage
Appendix F – Easement Special Requirements
Appendix G – Aqua Water Details
Appendix H – Aqua NC Specifications for Water
Appendix I – Claims Form
Appendix J – Lateral Relocation Release Form

Appendix K- Water Permit  
Appendix L – Sewer Permit

## **SECTION D – TECHNICAL SPECIFICATIONS**

**\*\*\* THIS PAGE WAS INTENTIONALLY LEFT BLANK \*\*\***

**DIVISION 2  
SITE WORK  
02110 - SITE CLEARING FOR PWC UTILITIES**

**SCOPE**

Work described in this section includes clearing and grubbing site, protecting adjoining property and trees as indicated on the drawings or as specified herein. The work shall include the complete removal and satisfactory disposal of all growth including trees, stumps, logs and roots; organic material, and other debris or items that interfere with construction operations. The site clearing operations shall be conducted in a manner to insure minimum interference with roads, streets, walks, and other adjacent occupied or used facilities.

**PROTECTION OF TREES AND VEGETATION**

Trees and vegetation to be left standing shall be protected from damage incidental to clearing, grubbing, and construction operations, by the erection of timber barriers or by such other approved means. Such barriers must be placed and approved by the Engineer before construction operations can proceed. The protection shall include unnecessary cutting, breaking or skinning of roots; skinning and bruising of bark; smothering of trees by stockpiling construction materials or excavated material within the drip lines; excessive foot and vehicular traffic including parking of vehicles within drip line. Trees and vegetation receiving damage shall be repaired or replaced in a manner acceptable to the Engineer.

Trees designated to be left standing within the cleared areas shall be trimmed of dead branches 1½ inches or more in diameter and shall be trimmed of live branches to such heights and such manner as directed. Limbs and branches to be trimmed shall be neatly cut close to the hole of the tree or main branch. Cuts more than 1½ inches in diameter thus made shall be painted with an approved tree wound paint.

**CLEARING AND GRUBBING**

Clearing shall consist of the felling, trimming and cutting of trees into sections, and the satisfactory disposal of the trees and other vegetation designated for removal, including down timber, snags, brush, and rubbish occurring within the areas to be cleared. Trees, stumps, roots, brush, and other vegetation in areas to be cleared shall be cut off flush with or below the original ground surface except such trees and vegetation as may be indicated or directed to be left standing. Clearing operations shall be conducted so as to prevent damage by falling trees to trees left standing, to existing structures and installations and to those under construction, and so as to provide for the safety of employees and others.

Grubbing shall consist of the removal and disposal of stumps, roots larger than 3 inches in diameter, and matted roots from the designated grubbing areas. This material, together with logs and other organic or metallic debris not suitable shall be excavated and removed to a depth of not less than 3 feet below any subgrade shoulder and slope surfaces in excavated areas indicated to be grubbed and in areas indicated as construction areas under this contract such as areas for buildings, roads, streets, shoulder areas, sidewalks. Depressions made by grubbing shall be filled with suitable material compacted to make the surface conform to the original adjacent surface of the ground. The required fill material will not be measured or paid for but should be included as

part of the grubbing cost. Grubbing inside the drip line of trees to be left standing shall be by hand methods.

The combined item of clearing and grubbing shall also include the removal and satisfactory disposal of fences, steps, walls, building foundations, pavement, other rubble and debris.

### **DISPOSAL**

All timber, logs, stumps, roots, brush, rotten wood, and other debris from the clearing and grubbing operations shall be disposed of off-site in an approved disposal pit. Such approval will include the conditions covering the disposal of such logs and stumps without burning, including the disposal area off-site. The contractor will be responsible for compliance with all state and local laws and regulations. Burning of timber and other refuse is not allowed within the City of Fayetteville.

**DIVISION 2  
SITE WORK  
02111 - SITE CLEARING FOR PWC UTILITIES**

**SCOPE**

Work described in this section includes clearing and grubbing, site, protecting adjoining property and trees as indicated on the drawings or as specified herein. The work shall include the complete removal and satisfactory disposal of all growth including trees, stumps, logs and roots; organic material, and other debris or items that interfere with construction operations. The site clearing operations shall be conducted in a manner to insure minimum interference with roads and other adjacent occupied or used facilities.

**PROTECTION OF TREES AND VEGETATION**

Trees and vegetation to be left standing shall be protected from damage incidental to clearing, grubbing, and construction operations. The protection shall include un-necessary cutting, breaking or skinning of roots; skinning and bruising of bark; smothering of trees by stockpiling construction materials or excavated material within the drip line; excessive foot and vehicular traffic including parking of vehicles within drip line. Trees and vegetation receiving damage shall be repaired or replaced in a manner acceptable to the Engineer.

Trees designated to be left standing within the cleared areas shall be trimmed of dead branches 1 -1/2" or more in diameter and shall be trimmed of live branches to such heights and such manner as directed. Limbs and branches to be trimmed shall be neatly cut close to the bole of the tree or main branch. Cuts more than 1-1/2" in diameter shall be painted with an approved tree wound paint.

**CLEARING AND GRUBBING**

Clearing and grubbing shall be performed within the permanent right-of-ways. In the interest of conserving natural resources and protecting the environment, clearing shall be kept to a minimum within the temporary right-of-ways limits. Where permanent and temporary right-of-ways are offset, the additional temporary area may be used as a "buffer" zone to aid in sediment control where possible. Clearing shall consist of cutting trees, with a stump left not more than two inches (2") above natural ground. Saleable timber shall become the property of the Contractor. Reasonable care shall be taken during construction to avoid damage to vegetation not located in the right-of-ways. Ornamental shrubbery and tree branches shall be temporarily tied back, where appropriate, to minimize damage. Trees which receive damage to branches shall be trimmed to improve the appearance. Tree trunks receiving damage shall be treated with approved tree dressing.



Several areas along the main where a temporary easement is indicated on the plans and is located in people's yards, the Contractor shall limit clearing only as absolutely necessary for the sewer installation. Where possible, individual trees shall be worked around and preserved. These particular areas will be noted on the plans.

In the interest of erosion and sediment control, if possible, clearing and grubbing should be staged in ½ mile sections or less. In all cases, the time of disturbance between clearing and grubbing operations and actual sewer line construction should be kept to a minimum, particularly if ditches and temporary roads are utilized for access to the project.

\*\*\* END OF SECTION \*\*\*

**DIVISION 2  
SITE WORK  
02211 - GRADING, UTILITIES**

**GENERAL**

This section covers grading for the roadways and drives including all excavations, formation of embankments, preparation of subgrade for pavements and finishing and dressing of graded earth areas, shoulders, and ditches.

**MATERIALS**

Topsoil, material obtained from excavation suitable for topsoils, is defined as natural, friable soil, characteristics of representative soils in the vicinity that produce heavy growth of crops, grass, or other vegetation. Topsoil shall be free from roots, stones, and other materials that hinder grading, planting, and maintenance operations, and free from objectionable weed seeds.

Satisfactory soil materials are defined as those in accordance with AASHTO Soil Classification Groups, A-1, A-2-4, A-2-5 and A-3 (or in accordance with ASTM D2487 soil classification groups GW, GP, GM, SM, SW, SP, SC.) as determined by the Engineer. Satisfactory material shall be free from roots, organic matter, trash, debris, frozen material or stones larger than three (3) inches in any dimension.

Unsatisfactory soil materials are defined as those in accordance with AASHTO Soil Classification Groups A-2-6, A-2-7, A-4, A-5, A-6, A-7 (or in accordance with ASTM D2487 soil classification groups GC, ML, MH, CL, CH, OL, OH, and PT) as determined by the Engineer.

Materials determined by the Engineer as too wet or too soft to provide a stable subgrade, foundation, or fill will be classified as unsatisfactory regardless of soil classification. The Engineer may require the Contractor to condition the wet and/or soft soils to provide a stable subgrade, foundation, or fill. The Contractor shall recondition the materials at no additional cost to the Owner.

**CONSERVATION OF TOPSOIL**

Areas designated for operations that contain a blanket of soil, which is more satisfactory for the growth of grass than the embankment material to be placed, shall be stripped to a depth of approximately four (4) to six (6) inches and placed in convenient stockpiles as directed in the field, for later use as a topsoil blanket on the new graded areas specified herein, or as designated. The stripping of material for use as topsoil shall be carefully determined and only the quantity required shall be stripped and stockpiled. Material ordered stockpiled shall be placed in a satisfactory manner to afford drainage. When grading operations permit, instead of stockpiling, the topsoil shall be hauled and spread directly on the areas to receive topsoil.

Topsoil shall be placed on all shoulders, slopes, ditches, and other earth areas graded under this contract, excluding borrow areas, unless otherwise specified on the plans. Topsoil shall be uniformly placed on these areas to a compacted depth of not less than three (3) inches or more than four (4) inches. The material shall be free from clods of soil, matted roots greater than ½ inch in diameter, and any other objectionable material which might hinder subsequent grass and mowing operations. The material shall be placed, leveled, and lightly compacted with at least one

pass of a cultipacker, or other approved equipment weighing 100 to 160 pounds per linear foot of roller, to required cross sections, but shall be left one-tenth of a foot below the finished earth grade as specified in the paragraph FINISHED EXCAVATION.

### **BORROW EXCAVATION** (Select Backfill)

Where satisfactory materials are not available in sufficient quantities from the required excavation, approved materials shall be obtained from borrow areas. Borrow excavation material shall be supplied by the Contractor from borrow areas located off-site. The work covered by this section shall consist of the excavation of approved material from borrow sources and the hauling and utilization of such material as required on the plans or directed by the Engineer. The borrow material shall be approved by the Engineer and shall not contain roots, root mats, stumps, highly plastic clay or other unsatisfactory materials. The material shall be a soil material which meets requirements of AASHTO M 45 for soil classification A-i-a, A-i-b, A-2-A, A-3 acceptable for select backfill. All borrow material shall be in accordance with the NCDOT Standard Specification for Roads and Structures, most recent edition. Borrow excavation shall be in accordance with the NCDOT Standard Specification for Roads and Structures, most recent edition. Excess material removed within the work limits, suitable for borrow excavation, during "Unclassified Excavation" operations shall not be considered or paid for as borrow excavation.

### **UNDERCUT EXCAVATION**

When the Owner determines that the natural soil materials in areas where fill is to be placed, or in the finished graded subgrade roadway cross section, or in areas supporting structures or pipes, are determined to have a poor supporting value, the Engineer may require the Contractor to remove the materials and backfill with approved properly compacted material to the finished graded section. The Contractor shall conduct undercut operations in such a way that the Engineer can take the necessary measurements before any backfill is placed. Any material removed and backfilled without the approval of the Engineer, and/or all necessary measurements taken, and/or to a depth, length or width exceeding the dimensions shall not be considered undercut excavation and will not be paid for such. All undercut excavation shall be in accordance with the NCDOT Standard Specification for Roads and Structures, most recent edition. Undercut excavations suitable for backfill on toes of slopes and other approved areas will not be paid for as borrow excavation.

### **FINISHED EXCAVATION**

All areas covered by the project, including excavated and filled sections and adjacent transition areas, shall be uniformly smooth-graded. The finished surface shall be reasonably smooth, compacted, and free from irregular surface changes. The degree of finish shall be that ordinarily obtainable from blade-grader operations, except as otherwise specified. Ditches shall be finished to permit adequate drainage. The surface of areas to be turfed shall be finished to a smoothness suitable for the application of turving materials. Surfaces shall be finished not more than 0.15 foot above or below the established grade and approved cross section. In areas where the bulking of soil as a result of grassing operations will tend to retard surface drainage along the edge of pavements, the finished grades shall be left 0.1 foot below grade prior to grassing.

Newly graded areas shall be protected from traffic and from erosion, and any settlement or washing away that may occur from any cause, prior to acceptance, shall be repaired and grades

re-established to the required elevations and slopes. Embankments and excavations shall be kept shaped and drained. Ditches and drains along subgrade shall be maintained in such a manner as to drain effectively at all times. The finished subgrade shall not be disturbed by traffic of other operations and shall be protected and maintained by the Contractor in a satisfactory condition until subbase, base, or pavement is placed. The storage or stockpiling of materials on the finished subgrade shall not be permitted. No base course or pavement shall be laid until the subgrade has been checked and approved, and in no case shall base, surfacing, or pavement be placed on a muddy, spongy, or frozen subgrade. All work shall be conducted in accordance with the environmental protection requirements of the contract.

**DIVISION 2  
SITE WORK  
02222 - EXCAVATION AND BACKFILLING FOR UTILITY SYSTEMS**

**GENERAL**

Work described in this section consists of the excavation, backfill, compaction, and finish grading required to install the utility systems. The intent and purpose of these specifications is to require a complete and satisfactory installation in every respect and any defect in material or workmanship shall be cause for the replacement and correction of such defect as directed by the Public Works Commission.

**RELATED SECTIONS**

- A. 02305 – Pipe Bursting
- B. 02660 – Water Distribution
- C. 02730 – Sanitary Sewer Systems
- D. 02732 – Sewage Force Mains
- E. Chapter 24 of the City of Fayetteville Ordinance (most recent version)

**MATERIALS**

Suitable soil materials are defined as those in accordance with AASHTO Soil Classification Groups A-1, A-2-4, A-2-5 and A-3 (or in accordance with ASTM D2487 soil classification groups GW, GP, GM, SM, SW, SP, SC) as determined by the Public Works Commission. Suitable material shall be free from roots, organic matter, trash, debris, frozen material or stones larger than three (3) inches in any dimension.

Unsuitable soil materials are defined as those in accordance with AASHTO Soil Classification Groups A-2-6, A-2-7, A-4, A-5, A-6, A-7 (or in accordance with ASTM D2487 soil classification groups GC, ML, MH, CL, CH, OL, OH, and PT) as determined by the Public Works Commission. Unsuitable material as defined above shall be replaced with select material as determined by the Public Works Commission.

Suitable materials determined by the Public Works Commission as too wet or too soft to provide a stable subgrade, foundation, or fill will be deemed as unsuitable regardless of soil classification. Materials deemed unsuitable shall be conditioned or replaced, as directed by the Public Works Commission. The Contractor shall recondition and stockpile the materials at no additional cost to the Public Works Commission.

**EXCAVATION**

All excavation shall be to the lines and grades indicated. The work shall consist of the excavation, placement, and compaction of suitable material as outlined in this Specification and proper disposal of all unsuitable materials. During excavation, suitable material for backfilling shall be stockpiled. The stockpiles shall be protected from contamination by unsuitable excavated material or other material. If any material becomes unsuitable, such material, if directed, shall be removed and replaced with suitable on-site or imported material from approved sources at no additional cost to the Public Works Commission.

Where the line parallels a creek and/or ditch the excavated material shall be stockpiled opposite the creek, with the trench separating the two. Adequate drainage shall be provided for the stockpiles and surrounding areas by means of ditches, dikes, or other approved methods. Grading shall be done to prevent surface water from entering the excavation. Any water within the trench shall be removed.

Suitable excavated material shall be stockpiled or placed in the excavation's backfill. Excavation and filling shall be performed in a manner and sequence that will provide drainage at all times. Unauthorized over excavation shall be backfilled with select bedding material at no additional cost to the Public Works Commission. The Contractor, at their expense, shall properly dispose of all excess excavated material unless directed to place it in another area of the project by the Public Works Commission. The Contractor's obligation to remove and dispose of excess materials shall in no manner convey to him any rights of property in any material taken from any excavation.

It shall be the Contractor's responsibility to investigate the site and existing conditions. No compensation will be allowed due to excavation and/or grading being different than anticipated.

### **TRENCH EXCAVATION**

The trench width shall be in accordance with PWC standard details. All work shall be in accordance with the applicable OSHA regulations.

The subgrade beneath the centerline of the pipe shall provide uniform support for each section of the pipe. Stones three (3) inches or greater in any dimension, or as recommended by the pipe manufacturer, whichever is smaller, shall be removed.

Where unsuitable material is encountered at the elevation established for installation of pipe or structures, additional undercut excavation shall be done as directed by the Public Works Commission. The additional undercut excavated area shall be backfilled with stone bedding material. Unauthorized undercut excavation shall be backfilled with stone bedding material and compacted as directed by the Public Works Commission. The Contractor shall conduct undercut operations in such a way that the Public Works Commission can take the necessary measurements before any backfill is placed. Any material removed and backfilled without the approval of the Public Works Commission, and/or all necessary measurements taken, and/or to a depth, length or width exceeding the dimensions shall not be considered undercut excavation and will not be paid for such.

Where unsuitable material is encountered at the elevation established for installation of roads, parking lots, or other paved areas, additional undercut excavation shall be done as directed by the responsible agency (i.e., City of Fayetteville, Town of Hope Mills, NCDOT, etc.). The additional undercut excavated area shall be backfilled with stone bedding material. Unauthorized undercut excavation shall be backfilled with stone bedding material and compacted as directed by the responsible agency. The Contractor shall conduct undercut operations in such a way that the responsible agency can take the necessary measurements before any backfill is placed. Any material removed and backfilled without the approval of the responsible agency, and/or all necessary measurements taken, and/or to a depth, length or width exceeding the dimensions shall not be considered undercut excavation. All undercut excavation shall be in accordance with

the NCDOT Standard Specification for Roads and Structures (most recent edition), or the responsible agency's specifications.

Excavation for manholes, meter vaults, or similar structures shall leave a minimum of 12-inches clear space around the structure. Removal of unsuitable material shall be as specified above. Preparation of the subgrade shall be in accordance with the applicable detail and as directed by the Public Works Commission.

### **PIPE LAYING**

All pipe shall be installed in accordance with PWC Specification Section 02660 – Water Distribution, Specification Section 02730 – Sanitary Sewer Systems, and/or PWC Specification Section 02732 – Sewage Force Mains.

### **TRENCH SAFETY**

All excavations shall comply with all Federal, State, and local rules and regulations. The Contractor shall have a trenching and shoring "competent" person on the job at all times when there is an open excavation. Under no circumstance shall an employee of the Public Works Commission be considered the "competent" person for the operation.

### **TRENCH STABILIZATION (SHORING)**

The Contractor shall furnish, install, and maintain all necessary shoring to ensure a safe excavation. The method of shoring and excavation shall be in strict accordance with OSHA Regulations. The Contractor shall be responsible for installation, maintenance, and removal of all trench stabilization measures. The Contractor shall be responsible for any damage to adjacent structures resulting from the installation, maintenance, removal, or absence of trench stabilization measures.

### **DEWATERING**

Excavations shall be kept dry at all times. Any required dewatering shall be the Contractor's responsibility. The Contractor shall be responsible for any damage to the adjacent property resulting from the installation, maintenance, discharge, and removal of the dewatering system. All discharge from the dewatering system shall be in accordance with the applicable erosion control rules and regulations.

## **BACKFILL**

Backfill shall consist of suitable material free from debris, stone, etc. The backfill shall be brought up evenly on both sides of the pipe for the full length of the pipe. The backfill operation shall be conducted to prevent damage and/or movement of the pipe.

Backfill material in trenches shall be placed in layers not exceeding six (6) inches loose thickness to a point at least 12-inches above the pipe compacted to 90 percent maximum density. The remainder of the trench shall be backfilled in layers not exceeding six (6) inches in loose thickness compacted as specified in subparagraph COMPACTION. Each layer shall be thoroughly compacted by an approved mechanical tamping device.

Backfill material around structures shall be placed in a manner that the structure will not be damaged. No backfill shall be placed around manholes, thrust blocks, or similar structures until the concrete has been allowed to cure for three (3) days. The backfill material shall be compacted as specified in subparagraph COMPACTION.

No backfilling will be allowed when weather conditions prevent compliance with these Specifications.

## **BORROW EXCAVATION (Select Backfill)**

Borrow excavation material shall be supplied by the Contractor when sufficient quantities of suitable materials are not available within the project limits. The borrow material shall be approved by the Public Works Commission and shall not contain roots, root mats, stumps, highly plastic clay or other unsatisfactory materials. All borrow material shall be in accordance with the NCDOT Standard Specification for Roads and Structures, most recent edition.

## **COMPACTION**

Backfill shall be compacted in accordance with the following table as a percentage of the maximum density at optimum moisture content as determined by the Standard Proctor Test, ASTM D-698.

<u>Area</u>	<u>Percent ASTM D-698 Maximum Dry Density</u>
Around and 1' above top of pipe	95
Remaining trench (within 4' of subgrade)	95
Pavement subgrade and shoulders	
Last 1' of fill (below subgrade)	100
Last 3' of fill to 12" below subgrade	98
Base material	100
Adjacent to structures (Areas not paved)	95
Under structures	98
Utility Outfalls (Cross Country)	95

Compaction testing may be performed at the option of PWC Project Coordinator, or as required by the responsible agency (i.e., City of Fayetteville, NCDOT, etc.). Compaction testing shall be



done in accordance with the responsible agency's requirements. Deficiencies shall be corrected by the Contractor without additional cost to PWC.

**FINISHED EXCAVATION**

All areas covered by the project shall be uniformly graded to the established elevations and approved cross sections. Ditches shall be graded to permit proper drainage. Newly graded areas shall be protected from traffic and/or from erosion, and any settlement or washing prior to acceptance shall be repaired and the required grades re-established. Ditches and drains along the subgrade shall be maintained to drain at all times. The finished subgrade shall be protected and maintained by the Contractor. The storage or stockpiling of materials on the finished subgrade shall not be permitted. No base course or pavement shall be laid until the subgrade has been checked and approved. All work shall be conducted in accordance with the environmental protection requirements of the Contract.

**DIVISION 2  
SITE WORK  
02272 - EROSION CONTROL - GENERAL PROVISIONS**

**GENERAL**

The Contractor shall be responsible for conducting his site grading and drainage operations in such manner as to prevent or lessen excessive soil erosion of the construction site work areas. He shall at all times provide satisfactory means to prevent or minimize the movement and washing of large quantities of soil. The Contractor is expected to review his site grading and drainage operations periodically to determine the areas most susceptible to erosion by excessive rainfall and periodically maintain all installed measures for the project duration. The Contractor shall correct any deficiencies or problem areas as directed by the Owner or the North Carolina Department of Environment and Natural Resources (NCDENR) inspector within 48 hours.

**EXECUTION**

The Contractor's attention is directed to the fact that unless exposed earth areas are properly cared for during construction, they may result in substantial sedimentation damage downstream from the construction area. He shall at all times provide satisfactory means to prevent or minimize the movement and washing of quantities of soil onto pavements or into adjacent ditches, swales, inlets, and drainage pipes, to avoid the possibility of these structures becoming clogged with soil. Should this happen as a result of erosion at the site of this construction, the Contractor will be required to immediately provide means for removal of the soil and/or debris from the structures to restore the proper functioning of these structures. The Contractor shall assume all responsibilities to the affected property owners for correction of all damages. The Contractor is expected to review his site grading and drainage operations periodically with the Owner with the view in mind of determining the areas most susceptible to erosion by excessive rainfall and shall take necessary temporary measures in sufficient time to minimize the washing away of the site soils that would likely occur before the areas are finished graded, topsoiled and planted. The temporary measures to be provided by the Contractor at the critical areas may consist of, but not limited to, any one or a combination of the following, or by other approved means selected by the Contractor:

Silt Fence  
Gravel Construction Entrance/Exit  
Inlet Protection

If any earthwork is to be suspended for any reason whatsoever for longer than 15 days, the disturbed areas shall be seeded with temporary vegetative cover or otherwise protected against excessive erosion during the suspended period. Suspension of work in any area of operation does not relieve the Contractor of the responsibility for the erosion control and temporary measures will not be considered cause for a change in the price bid.

**MAINTENANCE**

The Contractor shall inspect and maintain each erosion control measure until the project is stabilized and accepted. After each significant rainfall, the Contractor shall remove and dispose of silt accumulation from each individual measure. The following maintenance may be required for each specific erosion and sediment control measure:

Silt Fence:	Fabric shall be removed and replaced whenever deteriorated to such an extent the effectiveness is reduced. The toe of the fabric shall be buried a minimum of 6 inches.
Gravel Construction Entrance/Exit:	Periodic top dressing with two inches (2") of graded stone. Remove all objectionable materials spilled, washed or tracked onto public roadways.
Sediment Trap:	Remove sediment and restore trap to original dimensions when accumulated silt volume equals $\frac{1}{2}$ the design depth. Replace the contaminated gravel facing.
Gravel Inlet Protection:	Remove sediment as necessary to provide adequate volume. Replace contaminated gravel facing if required.
Rip-Rap:	Make repairs to dislodged stone and/or supplement as required if erosion occurs during heavy rainfalls.

## **REMOVAL**

After the area has been stabilized and the project accepted, the Contractor shall remove all temporary erosion and sediment control measures. Silt fences shall be removed, sediment traps/pits and/or basins filled with suitable soil, compacted and seeded. The materials removed shall remain the property of the Contractor and shall be disposed of off-site, or may be reused in other locations if approved by the Owner.

**DIVISION 2  
SITE WORK  
02273 - TEMPORARY SILT FENCE**

**GENERAL**

The work covered by this section consists of furnishing, installing, maintaining and removing a water permeable filter type silt fence for the purpose of removing suspended particles from the water passing through it.

The quantity of temporary silt fence to be installed will be affected by the actual conditions which occur during the construction of the project. The quantity of temporary silt fence may be increased, decreased, or eliminated entirely at the direction of the Owner. Such variations in quantity will not be considered as alterations in the details of construction or a change in the character of the work.

**MATERIALS**

Either wood posts or steel posts may be used. Wood posts shall be a minimum of 6 feet long, at least 3 inches in diameter, and straight enough to provide a fence without noticeable misalignment. Steel posts shall be 5 feet long, 1 3/4 inches wide and have projections for fastening the wire to the fence.

Wire fence fabric shall be at least 32 inches high, and shall have at least 6 horizontal wires. Vertical wires shall be spaced 12 inches apart. The top and bottom wires shall be at least 10 gage. All other wires shall be at least 12½ gage.

Burlap shall be at least 36 inches wide and shall weigh at least 6.7 ounces per square yard. Other materials may be used in lieu of burlap, provided those materials have been approved by the North Carolina Department of Environment and Natural Resources (NCDENR).

Wire staples shall be No. 9 staple and shall be at least 1½ inches long.

**INSTALLATION**

The Contractor shall install temporary silt fence as shown on the plans and details. The silt fence shall be constructed at the locations shown on the plans and at other locations directed by the Owner.

Posts shall be installed so that no more than 3 feet of the post shall protrude above the ground and at least 18 inches are driven into the ground. Filter fabric shall be attached to the wire fence fabric by wire or other acceptable means. The fabric shall be continual in length. The fabric shall extend into a 6"x 6" trench along the uphill side of the fence. The trench shall be backfilled and compacted. Place 6 inches of No. 57 stone along the toe of the fence to secure the fabric in place. The single stripe located approximately 6 inches from the silt fence outer edge should not be visible if the fabric and fencing are installed properly.

**DIVISION 2  
SITE WORK  
02274 - GRAVEL CONSTRUCTION ENTRANCE/EXIT**

**GENERAL**

The work covered by this section consists of furnishing, installing, maintaining and removing temporary gravel construction entrance/exits. The entrance/exit shall be located at points where vehicles enter and exit the project and as indicated on the plans to limit sediment "tracked" off the site.

Where there are differences or conflict between this specification and those requirements outlined in an approved Erosion Control Plan, the specifications in the erosion control plan shall take precedence

**MATERIALS**

The stone shall be two inch (2") to three inch (3") washed stone.

**INSTALLATION**

The Contractor shall install the gravel construction entrance as shown on the plans and details. The construction entrance shall be constructed at the locations shown on the plans and at other locations directed by the Engineer.

The area to receive the stone shall be cleared of all vegetation, roots and other objectionable materials. The subgrade shall be graded and properly compacted. Areas yielding shall be covered with engineering fabric or undercut as directed by the Engineer. The stone shall be placed, graded and compacted to a minimum depth of eight inches (8") and as shown on the plans. The minimum construction entrance dimensions shall be 50 feet in length and 12 feet in width. The construction entrance/exit shall be maintained and the stone supplemented throughout the life of the project and shall be removed upon stabilization and disposed of off-site at the Contractor's expense.

**DIVISION 2  
SITE WORK  
02275 - BLOCK AND GRAVEL INLET PROTECTION**

**GENERAL**

The Contractor shall install block and gravel inlet protection when storm drain inlets are to be made operational before permanent stabilization of the disturbed drainage area. The inlet protection applies to areas of heavy runoff and provides for overflow capacity to prevent excessive ponding; however, shallow temporary flooding should be anticipated.

**INSTALLATION**

The Contractor shall install the block and gravel inlet protection as shown on the detail drawing and at the locations indicated. As an option, the concrete blocks may be omitted and the entire structure made of gravel and stone. A structure made entirely of stone is commonly called a "gravel doughnut". In this case, keep the stone slope toward the inlet at 3:1 or flatter. Stone shall be washed stone with minimum 3-inch size on the basin side for stability and 1 inch or smaller (No. 57) on the flow side.

**DIVISION 2  
SITE WORK  
02301 – BORING AND JACKING (ROADWAYS AND RAILROADS)**

**GENERAL**

Installation shall be by dry boring and jacking of a smooth wall steel pipe that is true to line and grade under roadways or where indicated on the plans, all in accordance with these specifications and recommendations of the pipe manufacturer. The Contractor shall notify the Public Works Commission's Project Coordinator a minimum of seven (7) days prior to any contemplated work. All required permits and approvals shall be secured prior to commencing work.

**MATERIALS**

Materials to be used shall be appropriate for the installation method chosen by the contractor. All materials shall be submitted to the Public Works Commission for approval, prior to the Contractor commencing operations.

**Dry Boring & Jacking**

The casing pipe shall be spiral welded or smooth wall steel pipe in accordance with ASTM A53, Grade B having minimum yield strength of 35,000 psi. The carrier pipe installed for water or force main applications, within the casing pipe shall be CL 50 ductile iron restrained joint pipe. Use of pressure class ductile iron pipe for water mains is acceptable, in accordance with Specification Section 02660. Mechanical joint restraint systems (i.e., Mega-Lugs, grip-rings, field-lok gaskets, etc.) are not an acceptable means of restraint within the casing pipe for water mains or force mains.

The material for the gravity sanitary sewer carrier pipe shall be CL 50 ductile iron restrained joint pipe. All carrier pipes in sewer service shall have the appropriate lining and coating. Use of restraining gaskets (i.e., field-lok gaskets) is an acceptable means of restraint for gravity sewer mains. Use of mega-lugs (or equivalent) is not approved for restraint within casings.

The casing pipe minimum size and minimum wall thickness shall be in accordance with the following chart unless indicated otherwise on the drawings.

CARRIER PIPE (dia. in inches)	MIN CASING SIZE (inches)	WALL THICKNESS (inches)	RAILROAD WALL THICKNESS (inches)
4	10	0.188	0.188
6	12	0.25	0.281
8	16	0.25	0.281
12	24	0.25	0.375
16	30	0.312	0.469
18	30	0.312	0.469

24	36	0.375	0.532
30	42	0.5	0.625
36	48	0.5	0.688

The Contractor may substitute larger size casing pipe (particularly for sewer mains where grade and alignment are critical) with the proper wall thickness. A manual steering head or other approved guidance system is recommended for casing pipe 30 inches and larger and/or bores exceeding 100 feet in length.

## **INSTALLATION**

Installation using the selected method shall be true to line and grade, where indicated on the plans, all in accordance with these specifications and recommendations of the pipe manufacturer. The Contractor shall notify all affected parties a minimum of seven (7) days prior to any contemplated work.

It is recommended that the Contractor perform each bore before beginning the sewer line construction. The boring shall be performed from the "upstream" to "downstream" direction maintaining the critical downstream invert elevation. Should the bore termination not be on grade, a revised plan shall be submitted to PWC Water Resources Engineering for approval. No additional payment shall be made for any required corrective actions. The boring operations shall be conducted at all times in such a manner so as not to create a hazard to nor impede the flow of traffic.

The Contractor will be responsible for any repair costs if any settlement or damage to the roadway or railroad bed resulting from the boring operation occurs within one year after completion of the work. The Contractor shall maintain proper insurance as required by the permitting agency.

The Contractor shall submit all requested information as required by the permitting agency.

### **Dry Boring & Jacking**

The alignment and grade of the jacking shall be carefully established prior to beginning the operation. A licensed professional land surveyor shall provide staking to establish the correct alignment and grade. The licensed surveyor (or a licensed professional engineer) shall provide cut sheets to the Public Works Commission and the contractor.

Lubricants such as bentonite may be applied to the outside of the pipe to reduce frictional resistance during jacking. The boring auger shall not be a greater diameter than the outside diameter of the encasement and removal of the excavated material ahead of the pipe will be held to a minimum to prevent the formation of voids.

Voids occurring outside the encasement pipe shall be filled with 1:3 Portland cement grout and the ends of the encasement pipe closed with masonry after the carrier pipe placement. The voids shall be filled with 1:3 Portland cement grout at sufficient pressure to prevent settlement of the roadway or railroad. The method of grouting shall be as approved by the permitting agency.



If the installed casing is deemed to be unusable by the Public Works Commission and/or the permitting agency, the casing shall be abandoned by bricking each end and filling the casing with grout, or as directed by the permitting agency.

The Contractor shall locate all existing utilities in the proposed location of the jack and bore. Design of the casing shall be in accordance with PWC standards, and subject to PWC approval. The casing should have a minimum separation of 12-inches from existing utilities.

In the event two parallel casings are being installed, the minimum separation between the outside edges of each casing shall be five (5) feet, or as directed by the permitting agency. In the event of a conflict between this specification and the permitting agency's requirements, the more stringent shall apply.

The use of "back-taps" is not encouraged. The design engineer shall take all necessary steps to determine the location of existing utilities and evaluate the necessity of a back-tap. Should it be necessary to install a back-tap, the top of casing shall be a minimum of 12-inches below the bottom of the pipe to be tapped. All pipe and fittings from the tap location to the carrier pipe shall be restrained joint. Use of mechanical joint restraint systems (i.e., mega-lugs, grip-rings, etc) are allowed in such instances. The Public Works Commission shall review and approve all proposed back-tap locations.

**DIVISION 2  
SITE WORK  
02302 - HORIZONTAL DIRECTIONAL DRILLING**

**GENERAL**

The Contractor shall furnish all labor, equipment, materials, and incidentals necessary for the construction of a new potable water main by horizontal directional drilling as shown on the Contract Drawings and as specified herein. Horizontal Directional Drilling (HDD) is a method of trenchless pipe installation using a steerable drilling operation which directly installs a pipe along an alignment without a conventional open cut or open face. HDD operations shall be completed so as not to interfere or endanger surface activity. The Contractor shall furnish all labor, materials, equipment, and incidentals necessary to install the potable water main utilizing HDD.

**RELATED SECTIONS**

- A. Section 02222 – Excavation, Trenching and Backfilling for Utility Systems
- B. Section 02272 – Erosion Control – General Provisions
- C. Section 02500 – Traffic Control
- D. Section 02660 – Water Distribution
- E. Section 02737 – Ductile Iron Pipe for Horizontal Directional Drilling

Additionally, the Contractor shall be familiar with the “Horizontal Directional Drilling Good Practices Guidelines” (latest edition), as prepared by the HDD Consortium.

**PROJECT/SITE REQUIREMENTS**

- A. The Contractor is encouraged to perform his own subsurface investigation as they deem necessary to understand the full extent of the drilling conditions and requirements.
- B. HDD operations shall limit vibrations transmitted to surrounding structures so as not to cause damage.
- C. Contractor shall complete a pre-construction survey and video of the existing conditions of the entire site and 50 feet either side of the proposed alignment prior to commencing construction activities.
- D. All disturbed areas shall be restored in accordance with these Contract Documents.
- E. All HDD work within the rights-of-way of the North Carolina Department of Transportation (NCDOT) shall be subject to the requirements of NCDOT, as outlined in the approved encroachment.

**MATERIALS AND EQUIPMENT**

- A. Pipe shall be flexible restrained joint pipe in accordance with specification Section 02737 – Ductile Iron Pipe for Horizontal Directional Drilling.
- B. Fittings shall be of working pressure rating equal to or greater of the pipe to be joined. All fittings shall be in accordance with specification Section 02660 – Water Distribution.

C. Two (2) continuous detection wires shall be installed with any plastic pipe installed with HDD. The detection wire shall be minimum 12 gauge single strand, coated copper or copper clad steel wire that is suitable for underground use. There shall be no splices within the length of pipe installed via directional drill. The detection wire shall be firmly secured to the pipe throughout the installation process. The detection wire shall be installed in accordance with PWC requirements.

D. The lubricant shall be bentonite or polymer based slurry. The proposed drilling fluid shall be specified based on the geotechnical reports(s) and the Contractor's evaluation of the site conditions. The fluid manufacturer shall be on-site for the first batch preparation. The fluid manufacturer should prepare and provide the fluid management plan.

a. The drilling fluids shall be mixed in accordance with the manufacturer's recommendations and be appropriate for the anticipated soil conditions. No hazardous additives may be used.

b. The drilling fluid delivery system shall be leak free and have sufficient capacity for the length and diameter of the bore and soil conditions, to maintain borehole stability and reduce drag.

c. All drill fluids shall be captured, disposed, or recycled in a manner to prevent environmental degradation.

E. The drill rig and associated equipment shall be in good condition and capable of completing the project without significant delays. Drilling equipment shall be capable of a minimum of 150% of the anticipated drilling forces. The Contractor shall be required to have access to a backup drilling rig of similar or greater pulling capacity.

The drilling rig must:

a. Be grounded during operation

b. Be securely anchored to withstand operating forces

c. Maintain a leak free hydraulic powered system that is self-contained with sufficient pressure and volume to power the drilling operation for all HDD activities.

d. Include a guidance system operated by trained personnel who are aware of any magnetic or electromagnetic anomalies, and must consider such anomalies in the operation of the guidance system.

e. Include a steerable drill head compatible with the soil conditions encountered.

f. Include a system to monitor and record maximum pullback pressure during pullback operations.

## **INSTALLATION**

Though the installation process may be licensed or proprietary in nature, the Contractor shall not change any material, thickness, design, values or procedural matters stated in the submittals, without the prior knowledge and approval of the Public Works Commission. The Contractor shall submit, in writing, full details about component materials, their properties and installation procedures and abide by them fully during the entire course of the work.

The Contractor shall take all necessary measures to ensure the specified directional drill pipe is not damaged beyond the manufacturer's specified tolerances during delivery, storage, or installation. All piping materials shall be stored off of the ground and the proper measures shall be taken to protect the specified directional drill pipe from sunlight (as appropriate). Any gouges

or damage to the specified directional drill pipe beyond the manufacturer's tolerances will result in the pipe or section of the pipe, being rejected and replaced with undamaged pipe at no additional cost to the Public Works Commission. Installation guidelines from the pipe supplier shall be followed for all installations. Pipe shall not be installed in a manner that exceeds the recommended bending radius and safe pulling force.

The Contractor shall provide equipment to guard against electrocution and an alarm system on drilling equipment capable of detecting electrical current as it approaches electric lines. The Contractor shall maintain safe conditions and prevent damage at all times.

All excavations shall conform to OSHA requirements. Locations of the entry and exit pits shall be approved by the Public Works Commission prior to beginning construction. The site should be graded or filled to provide a level working area for the HDD rig. Excavating and backfilling entry and exit points shall be in accordance with local conditions and the Contract Documents. Site restoration shall be in accordance with the Contract Documents.

All existing utilities shall be located and protected as necessary. The Contractor shall coordinate any utility protection with the respective utility company. Utility coordination and protection shall be in accordance with these Contract Documents.

The Contractor shall transport and dispose of all waste soils, slurries and other wastes in accordance with applicable regulations at no additional cost to the Public Works Commission. Drilling fluids should be minimized at locations other than entry and exit points. The Contractor shall immediately clean up any drilling fluids that inadvertently surface (i.e., fracouts) in accordance with the approved work plan. No waste shall be left on-site following completion of the work. The Contractor shall dispose of all groundwater generated by dewatering operations and any surface water entering access pits in accordance with applicable regulations and these Contract Documents.

Prior to beginning HDD operations, the wireline tracking shall be installed and calibrated in accordance with the manufacturer's recommendations. In addition, the Contractor shall walk the project site to identify any objects that may interfere with the drilling operations, the proper operation of the receiver and transmitter, and/or pose any other concern with regards to the installation.

### **Horizontal Directional Drill Operations**

The Contractor shall notify the Public Works Commission a minimum of five (5) business days before commencement of work. At least one of the Contractor's field supervisors listed in the work plan shall be at the site at all times when HDD operations are in progress. The Contractor shall maintain operations 24 hours a day, seven days a week during drilling and pullback.

A protective bumper or roller shall be utilized to prevent the pipe from being dragged along the ground, damaged during the pullback operation and to reduce the pullback forces.

The Contractor shall follow the pipeline alignment shown on the Contract Drawings and the tolerances specified herein:

- A. Vertical alignment plus or minus 0.5 foot. Vertical path of the pilot hole shall not establish new high points not shown on the drawings.
- B. Horizontal alignment plus or minus 1.5 foot.
- C. Include electronic monitoring of horizontal and vertical drilling head location. Obtain accuracy range within 1 inch of actual position of pipeline. Record position readings at maximum of 10 foot intervals.

At completion of pilot hole drilling, the Contractor shall furnish the Public Works Commission tabulations of horizontal and vertical alignment. Any adjustments to the pipeline alignment shall be approved by the Public Works Commission before implementation.

The Contractor shall maintain close observation to detect settlement or displacement of surface and adjacent facilities, as well as frac-outs. The Public Works Commission shall be notified immediately if settlement, displacement, or frac-out is detected. The Contractor shall immediately respond to a frac-out and take all necessary measures to control and contain the drilling fluid. The Contractor shall take complete responsibility for all costs related to the clean-up of the frac-out, and shall fully cooperate with the Public Works Commission in responding to and cleaning up the drilling fluid. The Contractor shall have the necessary materials and personnel to respond to a frac-out or other emergency.

The Contractor shall ream the pilot hole to a diameter which is sufficiently sized to reduce forces applied to the pipe during pull back. Table 1 provides recommendations for reamed diameter, based on pipe diameter. Final ream diameters less than 1.5 times the pipe O.D. must be approved by the Public Works Commission prior to initiating pullback.

Table 1. Pipe Diameter and Recommended Ream Diameter

Pipe Diameter	Recommended Ream Diameter
less than 8"	pipe diameter + 4"
8" through 24"	1.5 times pipe diameter
greater than 24"	pipe diameter + 12"

**Pipe Installation**

The Contractor shall install a swivel between the reamer and pipe connection to minimize torsional stresses imposed on the pipe. The Contractor shall protect the pipe during pull back so that it moves freely and is not damaged. The Contractor shall take necessary measures to prevent the specified directional drill pipe from exceeding its maximum allowable stress. Once the pullback operation has started, the operations shall continue to completion. The pullback should be a single uninterrupted operation. If this is not possible a plan shall be submitted to the Public Works Commission for approval, including details of the number of separate pull back operations required. Replace any pipe damaged during installation at no additional cost to the Public Works Commission.

The Contractor shall install the pipe from either a pit which allows the pipe installation along the proposed grade directly or by drilling an initial sacrificial tangent section outside the limits of the proposed pipe segment which is then excavated and cut-off to make the pipe connection at the grades indicated.

The Contractor shall maintain proper lubrication during pipe pullback to reduce the exterior friction and possibility of the pipe seizing in place.

If forward motion or operation is stopped by an obstruction, the Contractor shall abandon the drill in place with drilling fluid, unless otherwise directed by the Public Works Commission. Upon approval from the Public Works Commission, the Contractor shall attempt a second installation at an approved location. Withdrawals, abandonments, restarts and re-drills shall be completed at no additional cost to the Public Works Commission.

After installation, a minimum of 48 hours shall be allowed prior to cutting, in order for the specified directional drill pipe to experience stress relief. When connecting to an adjacent pulled or non-pulled section of pipe, the pulled section of pipe shall extend past the termination point. Sufficient pipe shall remain outside the borehole when pullback is completed, in order to connect to the direct bury portion of the project. After the stress relief, the specified directional drill pipe shall be cut to install the necessary valves, tees, and fittings as indicated on the drawings. All connections between the specified directional drill pipe and the direct bury pipe shall be restrained.

### **POST INSTALLATION CCTV INSPECTION**

The Contractor shall perform post installation internal television inspections to verify that the installation is acceptable as defined herein. The finished DVD shall be continuous over the entire length of the installed water main or as specified by the Public Works Commission. The data and stationing are to be on the video. All such inspections shall be performed by personnel trained in locating breaks, obstacles and service connections by closed circuit color television. All original DVDs remain property of the Public Works Commission.

The CCTV inspection shall be performed after all work is completed, prior to testing. The Public Works Commission may, at its option, conduct an inspection of the new pipe to determine its condition subsequent to the HDD, prior to all work being completed. Any defects, which, in the opinion of the Public Works Commission affect the integrity of the pipe shall be replaced or repaired by the Contractor at no additional cost to the Public Works Commission. All repairs shall be submitted to the Public Works Commission for review and approval prior to commencing any repair work.

The post-installation CCTV inspections shall be performed so that the inner pipe can be clearly seen (not too much or too little light). Pipelines shall be thoroughly cleaned prior to performing the television inspections so that the entire pipe, including the bottom, can be clearly seen. All connections shall be clearly shown. The camera shall be panned, tilted and rotated at all defects and at the service lateral or pressure main connections for a complete video documentation.

The CCTV inspection shall include video documentation and computer generated logs to document the inspection. The final footage of the post-rehabilitation inspection shall be within 1% of the actual pipeline length as measured above ground.

The Contractor shall submit a sample CCTV inspection after the first installation so that the Contractor and the Public Works Commission can agree on the performance and quality of the inspections which must be met throughout the Contract. Pipelines not inspected to the Public

Works Commission's satisfaction shall be re-inspected by the Contractor at no additional cost to the Public Works Commission.

One (1) copy of the DVDs and logs shall be submitted to the Public Works Commission for review and approval. Payment will not be made for any pipe installation until the Public Works Commission has reviewed and approved these videos. The Contractor shall submit the videos at least 10 days in advance of any payment request to provide the Public Works Commission ample time to review the videos.

## **REPORTING**

The Contractor shall maintain and update an operator logbook on a daily basis. The logbook shall include the drill locator's notes and records of the bore from the steering and tracking system. The logbook should also include pipe diameter, depth, pitch, steering commands, drilling fluid circulation/volume and pressure, drilling fluid composition, ground conditions, date, time on-site, footage obtained during that day, pulling forces, torsional forces and any pertinent notes. The logbook shall be legible, accurate, and shall be submitted to the Public Works Commission upon completion of the work and made available throughout the installation process.

## **GROUND SURFACE MONITORING**

Prior to beginning the HDD operation, the Contractor shall visually inspect the ground surface along the centerline and adjacent areas of the proposed bore. Any signs of settlement or heaving should be noted and reported to the Public Works Commission. The Contractor is required to survey and video existing conditions of the entire site and 50 feet either side of the proposed alignment prior to commencing construction activities. Surface elevations shall be surveyed within the prescribed drilling area in a grid pattern. Additional elevations of nearby structures such as roadways, bridges, buildings, slabs, etc. shall also be obtained. The video shall include any structures and their condition that are within the limits of construction or immediately adjacent to the work.

The Contractor shall monitor the ground surface along the centerline of the pipe, to observe any signs of settlement, heaving, or fracout due to the HDD operations. The Contractor shall make a visual inspection of the ground surface along the centerline of the pipe and adjoining areas on an hourly basis during the time of active drilling and backreaming. The Contractor shall record his visual observations for each inspection and provide this report to the Public Works Commission upon completion of the HDD operations.

If deemed necessary by the Public Works Commission, the Contractor shall establish surface settlement monitoring points along the centerline of the pipe and any additional monitoring points at locations deemed necessary. The monitoring points shall be installed in accordance with the following:

- a. Record location of settlement monitoring points with respect to construction baselines and elevations. Record elevations to an accuracy of 0.01 feet for each monitoring point location. Establish monitoring points at locations and by methods that protect them from damage by construction operations, tampering, or other external influences.

- b. Monitor ground settlement directly above and 10-ft before and after any utility or pipeline intersection.

The Contractor shall monitor these points during construction, and submit records of daily readings from the various surface settlement monitoring points. The Contractor shall immediately contact PWC if any loss of ground, roadway cracking, depression or settlement or other unusual activities are noted.

Settlement or heave of the ground surface along the HDD alignment shall not exceed 0.5-inches.

### **TESTING**

Water mains installed by HDD will be hydrostatically tested prior to installation, unless otherwise approved by PWC. Once installed, the water main shall be hydrostatically tested, chlorinated, and bacteriological testing conducted in accordance with Section 02660 – Water Distribution. The Contractor shall fully cooperate with PWC Project Coordinator to schedule and complete all testing.

### **ACCEPTANCE**

Acceptance of the pipe shall be based on conformance with the requirements herein, the Public Works Commission's review of the installation monitoring, CCTV inspection, logbook, and results of all testing.

\*\*\* END OF SECTION \*\*\*



**DIVISION 2  
SITE WORK  
02500 – TRAFFIC CONTROL**

**GENERAL**

The purpose of these specifications is to outline the Contractor's requirements for furnishing, erecting, maintaining, relocating, and removing traffic control devices for the maintenance of traffic during the Contractor's construction operations. The Contractor shall furnish all labor, materials, accessories, equipment and tools for performing all required traffic control operations.

**REFERENCES**

All work shall be in accordance with:

- A. The North Carolina Department of Transportation Standards and Specifications for Roads and Structures (most recent edition)
- B. The North Carolina Department of Transportation Roadway Standard Drawings (most recent edition)
- C. The Manual on Uniform Traffic Control Devices (MUTCD) – most recent edition
- D. The North Carolina Supplement to the MUTCD
- E. Section 01000 – Special Conditions, of these Contract Documents

**REQUIREMENTS**

**TRAFFIC CONTROL PLAN**

The Contractor shall submit a traffic control and phasing plan for the overall project to be reviewed and approved by PWC Project Engineer, prior to starting construction. The Contractor shall obtain an approved copy of the traffic control plan for the overall project area prior to any excavation within roadways. The plan must indicate how traffic will be managed, signage to be used, and potential traffic patterns resulting from plan implementation. The plan shall be submitted to PWC Project Engineer in accordance with Section 01000 "Special Conditions" and Section 01300 "Submittals" of these Contract Documents. Failure of the Contractor to submit the required traffic control plan sufficiently in advance shall not entitle the Contractor to any extension of Contract Time.

**TRAFFIC CONTROL DEVICES**

The Contractor working in public rights-of-way on streets open to vehicular traffic, shall be required to provide, erect, and maintain all necessary traffic control devices throughout the project area to include any connecting streets affected by construction activities. The Contractor shall provide a sufficient number of personnel, and take all precautions for the protection of the work and safety of the public. All traffic control devices in place shall be in accordance with the approved traffic control plan. All traffic control devices and device installation shall be placed and maintained in strict accordance with the resources listed above.

The Contractor shall be liable for any damages resulting from using unapproved and/or inadequate work zone traffic control. Fayetteville Public Works Commission reserves the right to stop any work for non-compliance. The Contractor shall have no claim for delay due to stoppage of work as a result of non-compliance.

## TRAFFIC CONTROL PLAN AND ROAD CLOSURE NOTIFICATION

1. TRAFFIC CONTROL PLAN – The Contractor shall notify PWC Project Engineer, in writing, by 5:00 p.m. Wednesday, indicating which roadways will be affected by the work the following week. The Contractor shall notify NCDOT of work to be done per the terms of the approved encroachment agreement. PWC Project Engineer shall receive copies of all correspondence via fax or email (PWC fax 910-829-0203; email addresses will be provided at the pre-construction meeting).

Traffic cannot be altered without notification and approval from the appropriate agency as outlined in the above paragraph. Failure to do so will result in the Contractor not being able to work within the street the next week.

No work on the individual streets shall start until all the traffic control devices required for the particular work activity have been installed in accordance with the approved traffic control plan.

2. ROAD CLOSURE NOTIFICATION - When deemed to be in the best interest of the public, Fayetteville Public Works Commission and the Contractor, a street may be closed for a duration mutually agreed upon. The Contractor shall submit a request in writing to PWC Project Engineer for approval to have a street closed. PWC Project Engineer will forward the request to the appropriate agency (i.e., City, Hope Mills, NCDOT) for approval of the closure. PWC Project Engineer will include their recommendation regarding approval or disapproval of the request. PWC Project Engineer will respond in writing with any recommendation for approval or disapproval of the request.

The request shall be submitted a minimum of five (5) business days prior to the desired closure date. The request shall include the street name and the limits of the closure based on the points of intersection. The request shall also state the proposed duration the street is to be closed and shall include a traffic control plan showing the detour route, traffic control devices, etc. The traffic control plan submitted shall be in accordance with the requirements listed in this Specification.

Once the street closure has been approved, in writing, by PWC Project Engineer, the Contractor accepts full responsibility for the closure, to include the installation, maintenance, and removal of all traffic control devices and all implied liability.

## STEEL PLATING ROADWAYS

Steel plating shall not be used without the prior written approval of the Project Engineer. The Contractor shall submit their proposed plan to utilize steel plates a minimum of five (5) working days prior to the proposed activity. Plating shall only be considered if the

trench depths are 14 feet or greater. Should plating be approved the Contractor shall adhere to the following:

1. The trench shall be adequately shored to support bridging and traffic loads.
2. The trench box shall be sealed so there are no open voids.
3. Steel plates shall rest on trench box.
4. Steel plates shall extend beyond the outer edges of the trench box on all four sides.
5. There must be a minimum of two (2) feet of compacted backfill above steel plates.
6. Compacted backfill shall match existing street grade.
7. Provide documentation that the plates are capable of supporting potential loads.

Steel plating shall not exceed two (2) consecutive calendar days in any given week. However, provided that work is progressing in that particular section of sewer the Contractor may be allowed to utilize plating for a longer duration as approved in writing by the Project Engineer.

#### **STEEL PLATING ROADWAYS (NCDOT STREETS)**

Steel plating shall not be used without the prior written approval of Fayetteville Public Works Commission Project Engineer. The Contractor shall submit their proposed plan to utilize steel plates a minimum of five (5) business days prior to the proposed activity. Should plating be approved, the Contractor shall adhere to the following:

1. The plates shall be secured against any movement from traffic. Options include "countersinking" the plates to be flush with the existing pavement, or bolting the plates to the pavement.
2. The plates shall overlap the excavation a minimum of two (2) feet on all sides.
3. The plates shall be sufficient to withstand the expected traffic loads.
4. Provide documentation that the plates are capable of supporting potential loads.

Steel plating shall not exceed two (2) consecutive calendar days in any given week. However, provided that work is progressing in that particular section of the project, the Contractor may be allowed to utilize plating for a longer duration as approved in writing by Fayetteville Public Works Commission Project Engineer.

#### **MATERIALS**

- A. The Contractor shall utilize interim pavement marking paint as specified in the North Carolina Department of Transportation Standards and Specifications for Roads and Structures (most recent edition)
- B. Traffic cones may be utilized when approved by Fayetteville Public Works Commission Project Engineer. If approved, traffic cones shall either be double stacked or weighted to prevent movement by traffic.
- C. All traffic control devices furnished by the Contractor shall remain the property of the Contractor, unless otherwise specified in these Contract Documents.

#### **INSTALLATION**

The furnishing, erecting, maintaining, relocating, and removal of traffic control devices shall be in accordance with the MUTCD (most recent edition), the requirements outlined in the approved traffic control plan, and these Contract Documents.

All traffic control devices shall be in place prior to the Contractor beginning work, removed during intervals when work is not on-going, and removed at the end of each business day (unless otherwise approved, as outlined in this specification).

The Contractor shall not obstruct or impede any traffic on adjacent streets, during the installation or removal of the traffic control devices, or during construction.

The Contractor shall not close a lane to through traffic after normal working hours and during periods of construction inactivity, unless otherwise approved in writing by Fayetteville Public Works Commission Project Engineer.

Fayetteville Public Works Commission Project Engineer may restrict the Contractor from placing lane closures during certain hours, holidays, or as deemed necessary for the convenience of the public. All lane closure types, hours of installation, and durations shall be as approved in writing by Fayetteville Public Works Commission Project Engineer.

The use of police and/or trained flaggers to control traffic through the work site shall be provided by the Contractor as required. The Contractor shall be responsible for obtaining trained personnel to direct traffic and contacting local authorities for use of police for traffic control where applicable.

#### **INTERIM PAVEMENT MARKINGS**

The Contractor shall be required to place interim pavement markings (centerlines, lane lines, edgelines, railroad, and school symbols) daily on any street with existing pavement markings that have been obliterated.

#### **THERMOPLASTIC PAVEMENT MARKINGS**

The Contractor shall be required to place thermoplastic pavement marking centerlines, lane lines, and edge lines within three (3) calendar days after the completion of the resurfacing operation.

The Contractor shall be required to place all thermoplastic pavement marking symbols (arrows, crosswalks, stop lines, school symbols, railroad symbols, raised pavement markers, etc.) within seven (7) calendar days of the completion of the project.

#### **NCDOT STREETS**

All traffic control measures for work within NCDOT road rights-of-way shall be in accordance with the approved NCDOT encroachment agreement, and as specified herein. Where there is a conflict between the requirements of this specification and the approved encroachment, the requirements of the approved encroachment shall govern.

\*\*\*END OF SECTION\*\*\*

**DIVISION 2  
SITE WORK  
02505 – ADJUSTMENT OF EXISTING STRUCTURES**

**GENERAL**

The work covered by this specification consists of the raising or lowering of existing manholes and valve boxes encountered within the limits of the project to match the adjacent finished work.

**RELATED SECTIONS**

- A. 02222 – Excavation and Backfilling for Utility Systems
- B. 02660 – Water Distribution
- C. 02730 – Sanitary Sewer Systems

Where conflicts occur between the specifications, the more stringent requirement shall apply.

**MATERIALS**

All materials shall be in strict accordance with the requirements of the Public Works Commission and as set forth in this standard.

Adjustable riser rings are not approved for use within the Public Works Commission water and/or sewer system. All manhole adjustments shall be done utilizing a concrete grade ring. If a concrete grade ring cannot be utilized, the manhole shall be broken down and rebuilt to the proper grade, in accordance with PWC standards.

**INSTALLATION**

Adjustment of structures shall not be performed until after placement of base course and/or any leveling course, and prior to placement of final course. All adjustments of structures shall be accomplished a minimum of 72 hours prior to placing the final surface course. All defective, damaged, or worn castings shall be replaced with new castings provided by the Public Works Commission at no cost to the Contractor. The Contractor shall be responsible for exchanging castings at the Public Works Commission's facility.

The Contractor shall take all necessary precautions to prevent debris from entering the sanitary sewer system. Any debris that falls into the manhole or valve box during adjustment shall be removed immediately.

**Manholes**

For all manholes that need adjustment, the Contractor shall remove all concrete grade rings to the top of the cone section. All loose material shall be removed and properly disposed of. The Contractor shall utilize new concrete grade rings to ensure that the new manhole ring and cover will be at final grade. If no concrete grade rings are required to adjust the structure to final grade, the Contractor shall set the ring and cover in a bed of clean fresh mortar.

If the manhole needs to be lowered, and there are no existing concrete grade rings, then the

Contractor shall tear down the existing manhole and rebuild it, utilizing new riser and cone sections, in order to ensure that the installed ring and cover will be at final grade. The Contractor shall remove all necessary sections of the existing manhole in order to make the adjustment.

If the manhole needs to be raised, and there are 12-inches of concrete grade rings already in place, the Contractor shall tear down the existing manhole and re-build it. The Contractor shall utilize new riser and cone sections, as required, to ensure that the installed ring and cover will be at final grade. The Contractor shall remove all necessary sections of the existing manhole in order to make the adjustment.

### Valve Boxes

In order to adjust valve boxes, the top section of the valve box shall be raised or lowered as required to meet the final grade. If the height of the final grade exceeds the length of the existing top section, the Contractor shall remove the existing valve box and install a new one at final grade.

All adjustments shall be protected for at least 72 hours before the placement of any surfacing material, in order to allow the concrete to properly set. The Contractor shall be responsible for protecting the raised structure from damage due to traffic. After the 72 hours, a temporary asphalt transition shall be placed around the raised structure, to allow vehicular traffic to pass over. The asphalt transition shall extend a minimum of 18 inches from the structure in every direction. The Contractor shall be responsible for maintaining this asphalt transition until such time the final surface course is placed. Immediately prior to paving, the asphalt transition shall be removed. In the event paving is stopped for the day prior to completing the work, the Contractor shall re-install the temporary asphalt transition. The finish surface tolerance shall not vary more than 1/4" (0.25 inch) in any direction. Every effort shall be made to ensure that the surface course and castings provide as smooth a ride as possible.

**DIVISION 2  
SITE WORK  
02573 – PAVEMENT PATCH**

**GENERAL**

Permanent pavement patching shall be completed as indicated on the Contract Plans and in accordance with these Contract Documents. The intent and purpose of these specifications is to require a complete and satisfactory installation in every respect and any defect in material or workmanship shall be cause for replacement and correction of such defect as directed by the Public Works Commission. All materials and workmanship shall be in complete accordance with the standards and specifications of the Public Works Commission and subject to Public Works Commission inspection and approval. The materials and installation shall conform to the North Carolina Department of Transportation (NCDOT) Standards, (latest revision), the NCDOT HMA/QMS Manual (latest revision), and as specified herein. The Contractor shall schedule an on-site pre-paving conference with PWC Project Engineer and Project Coordinator prior to performing any paving operation. The conference should include discussion on the definition and determination of a lot.

**REMOVAL**

The Contractor shall cut the existing pavement to straight uniform widths parallel and perpendicular to the roadway. Jagged saw cuts will not be acceptable. The pavement shall be removed its entire depth. The Contractor shall properly dispose of all removed pavement. If the Contractor elects to mill the asphalt, the millings cannot exceed two (2) inches in size, and shall be swept into the trench and re-compacted. The removal limits shall extend a minimum of six (6) inches into solid undisturbed base course prior to patching or as directed by the Public Works Commission.

Pavement removal shall not exceed 3,000 feet total for the entire project at one time. It shall be the Contractor's responsibility to maintain the trench (swept, wetted, compacted, etc.) until paved.

**PAVEMENT**

Replacing the pavement shall consist of the following:

**Tack Coat**

All existing pavement edges shall be tacked in accordance with the North Carolina Department of Transportation Standard Specifications for Roads and Structures (latest revision).

**Asphalt Surface Course**

The asphalt surface course shall be Type S9.5, placed in accordance with PWC Standard Detail M.2. All asphalt surface course shall be in accordance with the NCDOT HMA/QMS Manual (latest revision) and the North Carolina Department of Transportation Standard Specifications for Roads and Structures (latest revision).

The pavement repair shall be constructed to the line, grade, crown and cross section of the



existing street. The asphalt plant mix shall be compacted to density in accordance with the HMA/QMS Manual (latest revision). The Contractor shall provide a smooth transition from the existing pavement to the top of the backfill, so as to have no vertical drop (in any direction). The transitions shall only be removed the day of patch paving.

The permanent pavement patch shall be made within 30 days of installation of the line. If settlement should occur within one (1) year warranty period, the Contractor shall be required to remove asphalt, re-compact base and sub-base, and re-patch any areas of settlement at no expense to PWC. All repairs shall be in accordance with these Contract Documents.

### Base Course

The base course shall be aggregate base course (ABC) installed to a minimum eight (8) inches thickness (compacted) and extending a minimum of six (6) inches beyond the edge of the trench as indicated on PWC Standard Detail M.2. The base course shall be compacted to 100% maximum dry density at optimum moisture content as determined by the AASHTO T-99 as modified by NCDOT.

The Contractor, with permission of the Public Works Commission, may use asphalt concrete intermediate course, placed in a minimum four (4) inch layer extending a minimum of six (6) inches beyond the edge of the trench as indicated on the Permanent Patch Detail. The Asphalt Concrete Intermediate Course shall be in accordance with the North Carolina Department of Transportation Standard Specifications (latest revision), and the NCDOT HMA/QMS Manual (latest revision).

Prior to patch paving, the Contractor shall remove the upper ten (10) inches of backfill, if ABC is to be used or upper six (6) inches if Asphalt Concrete Intermediate Course is to be used, in the trench. All asphalt edges along the trench shall be cut straight, uniform width, parallel and perpendicular to the road with no jagged edges. The outer six (6) inches (minimum) of the trench adjacent to the newly removed asphalt shall be on undisturbed soil.

The pavement repair shall be constructed to the line, grade, crown and cross section of the existing street. The asphalt plant mix shall be compacted to density in accordance with the HMA/QMS Manual.

Maintenance shall be performed at least weekly, after a rainfall, or at the direction of the Public Works Commission. Maintenance shall include sweeping the adjoining pavement, blading, wetting and compacting the stone to insure smooth drivable surface.

**DIVISION 2  
SITE WORK  
02574 – TEMPORARY PAVEMENT PATCH**

**GENERAL**

Open cutting and replacing existing pavement shall be performed in accordance with these Contract Documents. The materials and installation shall conform to the North Carolina Department of Transportation Standard Specification (most recent edition), the NCDOT HMA/QMS Manual (most recent edition), and as specified herein. Encroachment permits will be obtained by the Public Works Commission, but all necessary insurance as required by NCDOT shall be furnished and paid for by the Contractor.

**REMOVAL**

The Contractor shall cut the existing pavement to straight uniform widths parallel and perpendicular to the roadway. Jagged saw cuts will not be acceptable. The pavement shall be removed its entire depth. The Contractor shall properly dispose of all removed pavement. If the Contractor elects to mill the asphalt, the millings cannot exceed two (2) inches in size, and shall be swept into the trench and re-compacted. The removal limits shall extend a minimum of six (6) inches into solid undisturbed base course prior to patching or as directed by the Public Works Commission.

Pavement removal shall not exceed 3,000 feet total for the entire project at one time. It shall be the Contractor's responsibility to maintain the trench (swept, wetted, compacted, etc.) until paved.

**PAVEMENT**

Replacing the pavement shall consist of the following:

**Tack Coat**

All existing pavement edges shall be tacked in accordance with the North Carolina Department of Transportation Standard Specifications for Roads and Structures (most recent edition).

**Asphalt Surface Course**

Where streets are indicated to be temporarily patched and overlaid with an asphalt surface course, the patch shall be constructed of asphalt intermediate course, Type I-19.0. The Asphalt Intermediate Course, material shall be in accordance with NCDOT Standard Specifications for Roads and Structures (most recent edition) and the NCDOT HMA/QMS Manual (most recent edition).

The pavement repair shall be constructed to the line, grade, crown and cross section of the existing street. The asphalt plant mix shall be compacted to density in accordance with the NCDOT HMA/QMS Manual (most recent edition).

The temporary pavement patch shall be a minimum three (3) inches compacted thickness and extend a minimum of six (6) inches beyond the edge of the trench in accordance with PWC

Standard Detail. No more than 24 hours prior to patch paving, the Contractor shall remove the upper three (3) inches of backfill in the trench. All asphalt edges along the trench shall be cut straight, uniform width, parallel and perpendicular to the road with no jagged edges. The outer six (6) inches (minimum) of the trench adjacent to the newly removed asphalt shall be on undisturbed soil. The Contractor shall provide a smooth transition from the existing pavement to the top of the backfill, so as to have no vertical drop (in any direction). The transitions shall only be removed the day of patch paving.

The temporary pavement patch shall be made within thirty (30) days of installation of the line. If settlement should occur within the one (1) year warranty period, the Contractor shall be required to remove asphalt, re-compact base and sub-base, and re-patch any areas of settlement at no expense to PWC. All repairs shall be in accordance with these Contract Documents.

**DIVISION 2  
SITE WORK  
02575 – DRIVEWAY REPLACEMENT GENERAL**

Removal and replacement of existing driveways is required as indicated in the Contract Drawings and shall conform to the requirements of this Specification and the Contract Documents. The Contractor shall furnish all labor, equipment, materials, and incidentals necessary for the removal and replacement of the driveways disturbed as part of the utility construction. The intent and purpose of these specifications is to require a complete and satisfactory installation in every respect and any defects in material or workmanship shall be cause for the replacement and correction of such defect as directed by the Public Works Commission at no expense to the Public Works Commission.

All work shall be done in accordance with the terms and conditions outlined herein, the Public Works Commission "Manual for the Design and Construction of Water and Wastewater System Extensions" (most recent edition), in accordance with the North Carolina Department of Transportation "Standard Specifications for Roads and Structures" (most recent edition), and subject to final approval and acceptance by the Public Works Commission. In case of conflicting requirements between this Specification and the above referenced documents, this Specification shall govern.

The Contractor shall provide resident's access to their driveways at all times. The Contractor shall coordinate with the resident to provide access to their home during removal and replacement of the driveway. The Contractor shall make every attempt to coordinate their efforts with the schedule and wishes of the resident.

**RELATED SECTIONS**

- A. 02222 – Excavation and Backfilling for Utility Systems

**REMOVAL**

The Contractor shall provide a neat edge along the concrete or asphalt driveway pavement being retained by sawing, straight and true, approximately two (2) inches deep before breaking away. The portion of driveway to be removed shall be as indicated on the Contract Drawings or as directed by PWC Project Coordinator. The concrete or asphalt driveway pavement shall be removed for its entire depth, removed from the site, and disposed of at the Contractor's sole expense.

The Contractor shall remove the existing gravel drive to the limits shown on the Contract Drawings or as directed by PWC Project Coordinator. The driveway shall be removed for its entire depth, removed from the site, and disposed of at the Contractor's sole expense.

**ASPHALT DRIVES**

Replacing the asphalt driveway shall consist of the following:

Base Course:

The stabilized aggregate base course shall be installed to a minimum eight (8) inches compacted thickness as indicated on the Asphalt Driveway Patch Detail. The base course shall be compacted to 100% maximum dry density at optimum moisture content as determined by the AASHTO T-99 as modified by NCDOT. In lieu of utilizing aggregate base course, the Contractor, with approval from the City of Fayetteville, may utilize a minimum of four (4) inches of I-19.0 intermediate course.

In locations approved by PWC Project Engineer, where the stone base course is to remain for a defined period of time prior to asphalt paving, the stone base course shall be maintained by the Contractor. Maintenance shall include sweeping the adjoining pavement, blading and/or leveling the stone, compacting and wetting the stone to insure smooth driveable surface. The Contractor shall have on the project the proper equipment to complete this work. Maintenance shall be performed at least weekly, after a rainfall, or at the direction of PWC Project Engineer.

#### Tack Coat:

All existing pavement edges shall be tacked in accordance with the North Carolina Department of Transportation Standard Specifications for Roads and Structures (most recent edition).

#### Bituminous Concrete Surface Course:

The bituminous concrete surface course shall be Type SF9.5, placed in a two (2) inch minimum thickness or to the existing full depth thickness whichever is greater and in strict accordance with the North Carolina Department of Transportation Standard Specifications for Roads and Structures (most recent edition).

### **CONCRETE DRIVES**

Where new concrete is to be placed against existing concrete, preformed expansion joint filler, three-quarter inches in width and of a depth extending for the full thickness of the slab, shall be used. All concrete shall have a minimum 28 day compressive strength of 3,000 psi and shall be placed to the same thickness as the removed portion except that in no case shall any new slab be less than five (5) inches thick. The concrete shall be accurately screed to produce a uniform surface, floated, and given a broom finish. All work shall be in accordance with PWC standard details and City of Fayetteville requirements.

### **GRAVEL DRIVES**

Gravel driveways shall be restored or replaced in all locations disturbed by construction. The replacement gravel driveway shall consist of six (6) inches thick compacted Number 57 stone or aggregate base course stone, whichever matches or more closely matches the existing gravel driveway.

### **ACCEPTANCE**

Acceptance of the installed driveways shall be based on the conformance with the requirements

outlined herein, the Public Works Commission's review of the installation, and written concurrence from the property owner. The Public Works Commission will not accept any installation without the written release from the property owner. The Contractor shall be responsible for obtaining the written release from the property owner.

**WARRANTY**

If settlement should occur within one (1) year, the Contractor shall repair/re-pave the area to provide a smooth transition between the new and existing driveways. The finished product shall be neat in appearance and of equal or exceeding quality of the surrounding driveway or area.

**DIVISION 2  
SITE WORK  
02584 - ROADWAY AND PARKING LOT MARKING**

**GENERAL**

The pavement markings shall be in strict accordance with both NCDOT Standard Specifications for Roads and Structures (most recent edition) and U.S. Department of Transportation, Federal Highway Administration's Manual for Uniform Traffic Control Devices for Streets and Highways.

**MATERIALS**

The traffic and zone marking paint shall be white, yellow or blue alkyd-chlorinated rubber chlorinated paraffin as manufactured by PPG Industries, General Paint and Chemical Company, Sherwin-Williams or an approved equal. The paint shall be in accordance with AASHTO M248, Type III.

**INSTALLATION**

The Contractor shall lay out all work including traffic lanes, arrows, spaces, handicap aisles, etc and other pavement markings as indicated on the Contract Drawings. Prior to the application of any paint, the pavement surface shall be cleaned of all dirt, trash and the surface shall be free of any material that would prevent adherence of paint. The paint shall be applied to a dry surface using either a template or striping machine. Stripes shall be uniform weight and width. Stripe width shall be 4 inches unless otherwise shown on the Contract Drawings.

**DIVISION 2  
SITE WORK  
02660 - WATER DISTRIBUTION**

**GENERAL**

Water lines and all appurtenant items shall be constructed of materials specified and/or as indicated on the approved drawings. The intent and purpose of these specifications is to require a complete and satisfactory installation in every respect and any defects in material or workmanship shall be cause for the replacement and correction of such defect as directed by Fayetteville Public Works Commission (PWC) at no expense to Fayetteville Public Works Commission.

**RELATED SECTIONS**

- A. 02211 – Grading, Utilities
- B. 02222 – Excavation and Backfilling for Utility Systems
- C. 02301 – Boring and Jacking (Roadways and Railroads)

**MATERIALS**

**MANUALLY OPERATED GATE VALVES**

All manually operated gate valves four (4) inches and larger shall be ductile iron or cast iron body resilient wedge type rated for 250 psig working pressure gate valves and shall conform to American Water Works Association (AWWA) C-509/C-515 and NSF 61. All valves must open counter-clockwise equipped with a two (2) inch square operating nut. The operating nut shall have an arrow cut in the metal, indicating the direction of opening. All valves shall have a non-rising stem. All valves up to and including thirty-six (36) inch diameter shall have triple "O" ring stem seals. The design and machining of valves shall be such as to permit the replacement of the upper two (2) "O" rings without undue leakage while the valve is wide open and in service. The wedge shall be ductile iron encapsulated in nitrile rubber (for four (4) inch through 12 inch) and SBR rubber for 14-inch through 24-inch sizes.. All internal and external surfaces of the valve body and bonnet shall have a fusion bonded epoxy coating complying with ANSI/AWWA C550 applied electrostatically prior to assembly, conforming to AWWA C-550-90. All valves up to and including 36-inch diameter shall have a safe working pressure of 250 psi. Valve connections shall be as required for the piping in which they are installed. Valves shall have a clear waterway equal to the full nominal diameter of the valve. All valves shall be tested for leakage and distortion in strict accordance with the latest revision of AWWA Specification C-500.

Gate valves installed in meter vaults shall have a wheel in lieu of a square operating nut and shall also have a non-rising stem. The wheel shall have an arrow cut in the metal indicating the direction of opening. Flanges shall not be buried. An approved pit shall be provided for all flange connections.

Resilient seated tapping valves shall be furnished with the tapping flange having a raised face or lip designed to engage the corresponding recess in the tapping sleeve flange in accordance with MSS-SP60. Tapping valves without the raised face on the tapping flange are not permitted since they do not assure the proper alignment required to prevent damage by a misaligned shell cutter.



The interior of the waterway in the body shall be a full opening and capable of passing a full sized shell cutter equal to the nominal diameter of the valve.

All valves shall be manufactured in strict accordance with the latest specifications of the American Water Works Association (AWWA). Valves shall be manufactured by: Mueller Company, Clow Corporation, or American Darling Company. Certification shall be furnished to Fayetteville Public Works Commission by the manufacturer that all valves are in accordance with PWC standards. Where specified on the plans and approved by Fayetteville Public Works Commission, resilient wedge gate valves may be furnished with spur gearing for valves installed in a vertical position and bevel gearing for valves installed in a horizontal position. All gate valves shall be installed in accordance with PWC standard details.

## BALL VALVES

For all valves smaller than four (4) inches, ball valves shall be used. Ball valves shall be installed in accordance with PWC standard details.

Ball valves shall be all bronze construction, with tee head operator and having a removable disc. Ball valves shall have threaded connections, in accordance with PWC standard details. Ball valves shall be manufactured and tested in accordance with AWWA/ANSI C800. The valve shall be equipped with packing nut, gland, and packing material. Ball valves shall be of an approved type made from approved materials conforming to ASTM Specifications and shall also meet the approval of the Public Works Commission. The turn required to travel from fully closed to fully open on the ball valve shall be 90 degrees.

## VALVE BOXES

Valve boxes shall be "slip-type" made of close-grained, gray cast iron metal painted with a protective asphaltic coating. Construction shall be in three pieces as follows: The lower of base pieces, which shall be flanged at the bottom, the upper part which shall be flanged on the lower end, and of such size as to telescope over the lower part, the upper end being constructed in the form of a socket to receive the cap or cover; and the cover or cap shall have cast on the upper surface, in raised letters, the word "WATER". All valve boxes shall be equal in quality and workmanship to those manufactured by Sigma Corporation (VB-462), Tyler Union (6855 Series), Star Pipe Products (VB-0004), or an approved equal. The valve box shall be installed in accordance with PWC standard details. The valve box shall have a 3/8-inch hole drilled in the upper part four (4) to six (6) inches from the top of the box to accommodate a 1/4-inch x 1-1/2-inch galvanized bolt for securing tracer wire.

Valve box protector rings shall be installed to protect valve boxes located outside pavement. The ring shall be constructed and installed in accordance with PWC standard details.

## FIRE HYDRANTS

All fire hydrants shall be dry barrel, traffic type and conform to the latest revision of AWWA Specification C-502 except as listed below or as otherwise directed by the Public Works Commission. All working parts shall be bronzed. The size of the fire hydrants (designated by the nominal diameter of the valve opening) shall not be less than four and one-half (4 1/2) inches.

All hydrants shall be able to deliver a minimum of 1,000 gallons per minute with a friction loss of not more than five (5) pounds per square inch (psi) total head loss through the hydrant. Hydrants shall be of compression type (opening shall be of such design that when the barrel is broken off the hydrant valve will remain closed and reasonably tight against leakage). All hydrants shall be mechanical joint to accommodate the spigot end of six (6) inch Pressure Class 150, AWWA Standard, ductile iron pipe. The installation of the fire hydrant shall be in accordance with PWC standard details. Bosses (6") may be substituted for tees in pipe sizes exceeding 24 inches in diameter, with prior approval from PWC. The boss shall be welded to the bottom of the main to provide effective flushing of the system.

All hydrants shall be furnished with two (2) two and one-half (2 ½) inch nozzles and one (1) four and one-half (4 ½) inch pumper nozzle. Outlets shall have American National Standard fire hose coupling thread, in accordance with the City of Fayetteville standard, and shall be provided with nozzle caps securely chained to the body of the hydrant. The base of the hydrant shall have two (2) cast lugs suitable for use in strapping the hydrant to the connecting pipe. The operating nut shall be pentagonal in shape, finished with a slight taper to one and one-half (1 ½) inches from point to flat to conform to the standard wrench used by Fayetteville Public Works Commission. All hydrants shall open left or counter-clockwise. Hydrants shall be suitable for working pressure of 150 psi and a test pressure of twice the working pressure. Fire hydrants shall be specific models manufactured by Mueller Company (Model Centurian 200), Clow Corporation (Medallion), American Darling (Model Mark 73-1) or approved equal. The interior of the hydrant shoe shall be coated with a four (4) mil thickness FDA approved epoxy coating.

#### COMBINATION AIR VALVES ASSEMBLY

Combination air valves shall be of the single housing style that combines the operation features of both an air/vacuum and air release valve. The combination air valve shall have a two (2) inch inlet and one (1) inch outlet connections and an orifice diameter to be determined by the Design Engineer for each project for a maximum working pressure of 300 psi. The assembly shall be equipped with a two (2) inch cut-off valve as shown on PWC standard detail. The combination air valve body shall be constructed of 316 stainless steel or reinforced nylon with the only exception being the Buna-N Rubber seat and gasket. Valves shall be as manufactured by Crispin (Model UX20), ARI (D-020), or approved equal. Combination air valves shall be installed in accordance with PWC standards.

#### WATER DISTRIBUTION PIPE

##### DUCTILE IRON PIPE

The raw material from all ductile iron pipe and fittings shall have an average minimum content consisting of 90% recycled iron and steel. Ductile iron pipe and fittings shall be manufactured in the United States of America in accordance with ANSI/AWWA A21.51/C151. The manufacturer of the ductile iron pipe shall be a member of the Ductile Iron Pipe Research Association (DIPRA).

All ductile iron pipe shall be designated as "Pressure Class", unless otherwise specified. The pipe furnished shall have a minimum thickness calculated in accordance with ANSI A 21.50 (AWWA C-150), with a factor of safety of two (2); a working pressure of 150 psi to 350 psi, plus 100 psi water hammer allowance; and AASHTO H-20 live truck load with 2.5 feet of cover. In no case shall "Pressure Class" pipe's nominal thickness be less than the following:

<u>NOMINAL SIZE</u>	<u>PRESSURE CLASS</u>	<u>THICKNESS (In.)</u>
4"	350	0.25
6"	350	0.25
8"	350	0.25
10"	350	0.26
12"	350	0.28
16"	250	0.30
24"	250	0.37

PUSH-ON JOINTS

Push-on joints shall be as specified and installed in accordance with AWWA C-600 and shall conform to AWWA Standard C-111. Push on joints, rubber gaskets and lubricant shall conform to ANSI A21.11. Pressure rating shall not be less than 200 psi unless otherwise specified. All ductile iron pipe shall be lined with standard thickness cement mortar lining and asphaltic seal coat in accordance with ANSI A21.4 (AWWA C-104). The pipe shall have an outside asphaltic coating as specified in AWWA Standard C-151.

## RESTRAINED JOINTS

### Factory Restrained Joints

Factory restrained joint pipe shall be utilized for all pipe greater than 12-inches in diameter, unless otherwise approved by Fayetteville Public Works Commission. Factory restrained joint pipe shall be furnished for the locations shown on the approved drawings. The pipe, joints, and gaskets shall be in accordance with ANSI/AWWA Standards as specified for ductile iron pipe. Factory restrained joints shall be rated for a working pressure of 350 psi for sizes up to 12-inches and 250 psi for larger sizes.

All factory restrained joint pipe shall have the restraints internal to the pipe (i.e., "boltless"). All restrained joint ductile iron pipe and fittings larger than 12-inches shall be as manufactured by U.S. Pipe's TR-Flex, Griffin Pipe Products SNAP-LOK, American Cast Iron Pipe Company's Flex-Ring Joint, or approved equal. The method of restraining the valves to the factory restrained ductile iron pipe shall be reviewed and approved by PWC on a case by case basis. The valves shall have the same working pressure as the pipe.

### Flanged Joints

Flanges shall be specifically designed for each application. The flange pipe shall be in accordance with ANSI/AWWA C-115/A21.15. Threads for threaded flange pipe shall be in accordance with ANSI B2.1, shop fabricated as outlined by AWWA 115 with serrated faces furnished on the pipe, completely factory installed. Welding of flanges to the body of the pipe will not be acceptable.

Ductile iron fittings and flanges shall be in accordance with ANSI/AWWA C-110/A21.10 with a minimum working pressure of 250 psi. Gaskets shall be full faced SBR rubber per ANSI/AWWA C-111/A21.11 with a minimum 1/8 inch thickness. Linings and coatings shall be as previously outlined for all ductile iron pipe and fittings.

### Mechanical Joints

Mechanical joints shall be as specified and installed in accordance with AWWA C-600 and shall conform to AWWA Standard C-111. Mechanical joints shall be of the stuffing box type and shall conform to ANSI A21.11 for four (4) inch pipe through 12-inch pipe. Mechanical joints, rubber gaskets and lubricant shall conform to ANSI A21.11. Pressure rating shall not be less than 200 psi unless otherwise specified.

Special accessories such as mechanical joint retainer glands or mega-lugs are acceptable on pipe 12-inches and less in diameter, upon approval from Fayetteville Public Works Commission.

Mega-lug and/or grip-ring restraint mechanisms will not be an acceptable method of restraint for pipe, fitting and/or valves on sizes larger than 12-inches in diameter. For mains larger than 12-inches and at locations specified by Fayetteville Public Works Commission, factory restrained joints shall be utilized, in accordance with these Specifications.

### Field Lok Gaskets

Special accessories such as US Pipe's Field-LOK gasket, Ford's Uni-Ring, or Romac's Grip-Ring are acceptable on pipe 12-inches and less in diameter, upon approval from Fayetteville Public Works Commission. Mega-lug and/or grip-ring restraint mechanisms will not be an acceptable method of restraint for pipe, fitting and/or valves on sizes larger than 12-inches in diameter. For mains larger than 12-inches and at locations specified by Fayetteville Public Works Commission, factory restrained joints shall be utilized, in accordance with these Specifications.

### FITTINGS

#### Mechanical Joint

All fittings shall be ductile iron and shall be manufactured in accordance with AWWA Standard C-110 (ANSI A21.11). Compact fittings shall be mechanically restrained, ductile iron in accordance with ANSI A 21.53 (AWWA C-153) for four (4) inch through 12 inch sizes only. Where thrust blocking is utilized, fittings shall be full body ductile iron in accordance with ANSI A 21.53 (AWWA C110).

All ductile iron fittings shall be lined with standard thickness cement mortar lining and asphaltic seal coat in accordance with ANSI A21.4 (AWWA C-104). All fittings shall have an outside asphaltic coating as specified in AWWA Standard C-151 and C-110, respectively.

#### Factory Restrained

Factory restrained joint fittings shall be utilized for all pipe greater than 12-inches in diameter, unless otherwise approved by Fayetteville Public Works Commission. Factory restrained joint fittings shall be furnished for the locations shown on the approved drawings. The fittings, joints, and gaskets shall be in accordance with ANSI/AWWA Standards as previously specified for ductile iron pipe. Factory restrained joints shall be rated for a working pressure of 350 psi for sizes up to 12-inches and 250 psi for larger sizes. All factory restrained joint fittings shall have the restraints internal to the fitting (i.e., "boltless"). All fittings shall be compatible with the factory restraint system. All restrained joint ductile iron fittings larger than 12-inches shall be as manufactured by U.S. Pipe's TR-Flex, Griffin Pipe Products SNAP-LOK, American Cast Iron Pipe Company's Flex-Ring Joint, or approved equal.

#### Bosses

Tangential welded on outlets (i.e., bosses) shall only be utilized on pipe 24-inches and larger, as approved by PWC. All bosses shall be factory welded; field fabrication is not allowed. The pipe shall be in accordance with these specifications. Bosses shall be of the size and location indicated on the approved drawings.

### AERIAL CROSSINGS

For aerial crossings, the ductile iron pipe shall be thickness class, as specified on the plans and standard details. All thickness class pipe shall be in accordance with ANSI A21.51 and AWWA C-151, with a minimum working pressure of 200 psi.

For aerial crossings which are four (4) inches to 12 inches in diameter, Class 53 manufactured factory restrained joint or Class 53 flanged ductile iron pipe shall be used in accordance with PWC standard details. No other means of restraint are allowed for aerial crossings. For aerial crossings larger than 12 inches, or as noted specifically on the plans, Class 53 flanged ductile iron pipe shall be used in accordance with PWC standard details.

All aerial crossings shall be designed and installed in accordance with PWC standard details.

### PIPE IN CASINGS

All ductile iron pipe (regardless of diameter) within casings shall be factory restrained, in accordance with these specifications and the applicable PWC standard details. The use of any other restraints (i.e., mega-lugs, grip-rings, etc.) shall not be utilized on pipe within casings.

All restrained joint ductile pipe in casings shall be in accordance with PWC standard details.

### TRENCHLESS APPLICATIONS

All ductile iron pipe (regardless of diameter) utilized for trenchless installations (i.e., horizontal directional drilling, pipe-bursting, etc.) shall be factory restrained, in accordance with these specifications and the applicable specification section for the trenchless technology. The use of any other restraints (i.e., mega-lugs, grip-rings, etc.) shall not be utilized.

### PVC PIPE

Two (2) inch water main pipe shall be manufactured using Grade 1 PVC compound material as defined in ASTM D-1784 and shall be SDR21, pressure class 200 in accordance with ASTM D 2241. Fittings for two (2) PVC pipe shall be solvent weld Schedule 80 PVC. Brass FIP x pack joint for PVC fittings shall be used to transition from PVC to brass. The pipe shall be plainly marked with the manufacturer's name, size, material (PVC) type and grade or compound, NSF seal, date of manufacture, pressure rating and reference to appropriate product standards.

All PVC pipe (4-inches through 12-inches diameter) shall be manufactured using virgin compounds as defined in ASTM D-1784, with a 4,000 psi HDB rating and designated as PVC 1120 to be in strict accordance with AWWA C-900. The pipe shall be Class 150 and conform to the thickness requirements of DR18. The pipe shall be manufactured to withstand 755 psi quick burst pressure tested in accordance with ASTM D-1599 and withstand 500 psi for a minimum of 1,000 hours tested in accordance with ASTM D-1598. The pipe joints shall be of the integral bell type with rubber gaskets and shall conform to the requirements of ASTM D-3139 or ASTM F-477.

PVC fittings are not acceptable for water mains four (4) inches or greater. Fittings and specials shall be ductile iron, bell end in accordance with AWWA C-110, 150 psi pressure rating unless otherwise shown or specified. Ductile iron fittings to PVC pipe shall be adequately supported on

a firm trench foundation. Ductile iron fittings and specials shall be cement mortar lined (standard thickness) in accordance with ANSI A21.4.

**Mechanical restraining systems (i.e. mega-lug, grip-ring) shall not be used on PVC pipe.**

#### TRACING WIRE

For the purpose of locating non-metallic pipes, a continuous "detectable" tracing wire shall be installed. The wire shall be a minimum 12 gauge, single strand, coated copper or copper clad steel wire that is suitable for underground use. Splices shall be accomplished utilizing a corrosion proof wire connector. The connectors shall "lock" the wires in place and contain a dielectric sealant to prevent corrosion. The connector shall be the "Snake Bite" connector manufactured by Copperhead Industries, LLC, or approved equal. The wire shall be buried continuously along the pipe. The wire shall be secured into valve boxes such that a direct/conductive metal detector may be used to trace the pipe location. Bolts shall be used to secure the wire and the attachment location shall be readily available from finished grade without special equipment.

#### POLYETHYLENE PLASTIC WATER TUBING

Polyethylene (PE) plastic water tubing shall be installed in accordance with PWC standard details. All services installed in new construction shall be one continuous run of pipe with no splices from the corporation stop to the meter. The PE water tubing shall meet the requirements of ASTM D2737, AWWA C901, and NSF Standards 14 and 61. Pipe dimensions shall meet Iron Pipe Size (IPS) standards.

The PE tubing material shall be high density polyethylene conforming to the minimum requirements of cell classification 445574E, as defined and described in ASTM D3350. The resin shall have a material designation code of PE4710 by the Plastic Pipe Institute.

The PE water tubing shall be SIDR 7, with a minimum pressure rating of 250 psi. Fittings for the PE water pipe shall be cast brass compression fittings, made to the PE water pipe dimension. All brass fittings shall have a 300 psi minimum pressure rating.

For the purpose of locating plastic water services during trenching, a continuous tracing wire shall be installed. The wire shall be a minimum 12 gauge, single strand, coated copper or copper clad steel wire that is suitable for underground use. The wire shall be buried along the water service lateral from the main to the meter box. The wire shall extend a minimum of 12 inches into the meter boxes.

#### COPPER WATER TUBING

Copper water tubing shall be installed in accordance with PWC standards. All services installed shall be one continuous run of pipe with no splices from the corporation stop to the meter.

Copper water tubing shall be Type K, soft copper manufactured in accordance with ASTM B88. The minimum pressure rating for the copper water pipe shall be 655 psi. Fittings for the copper water pipe shall be brass compression fittings, made to the copper water pipe dimensions. All brass fittings shall have a 300 psi minimum pressure rating.

#### TAPPING SLEEVES

Tapping sleeves shall be ductile iron mechanical joint or stainless steel and have a minimum working pressure of 150 psi for all tapping of mains up to and including 24-inch diameter with a branch less than or equal to 12-inches diameter. Branch diameter greater than 12-inches on a 16-inch diameter pipe and larger shall require full body ductile iron mechanical joint tapping sleeve.

Ductile iron mechanical joint tapping sleeves shall be as manufactured by Clow, M&H, Mueller, American, or an approved equal and shall be furnished with complete joint accessories. The mechanical joint sleeve shall be compatible with type and class of pipe being tapped. The outlet flange shall be class 125 per ANSI B16.1 compatible with approved tapping valves.

Stainless steel tapping sleeves shall be as manufactured by Romac, Smith-Blair, or approved equal, and shall be furnished with all accessories. The sleeve, lugs, bolts and nuts shall be 18-8 type 304 stainless steel, as provided by the manufacturer. The outlet flange shall be ductile iron or stainless steel. The gasket shall be a grid pattern design and shall provide full circumferential sealing around pipe to be tapped. The sleeve shall include a 3/4 NPT test plug. All welds shall be passivated. The outlet flange shall be class D per AWWA C-207-ANSI 150 lb. drilling compatible with approved tapping sleeves.

The tapping sleeve and valve shall be in accordance with PWC standard details.

All tapping sleeves shall be hydrostatically pressure tested prior to the tap being accomplished. **Use of air to complete the pressure test is not acceptable.** The tapping sleeve shall be tested to 150 psi. PWC Project Coordinator shall witness and approve the testing.

## WATER SERVICE SADDLES

All water service saddles for use on two (2) inch PVC shall be one (1) inch brass saddles as manufactured by Ford, McDonald, or Mueller.

Water service saddles for one (1) and two (2) inch taps on four (4), six (6), eight (8), 12-inch and larger size PVC and asbestos-cement (AC) and also four (4) inch and larger size iron pipe shall be ductile iron with stainless steel strap(s), bolts, nuts and washers. Ford Models FS 101, FS 202; Romac Models 101S, 202S; or Smith-Blair Model 315.317 shall be used. Stainless steel straps must be pre-formed at the factory to the specified outside diameters of the pipe.

Water service saddles with a two (2) inch outlet shall be double strap.

Water service saddles for pipe sizes 12-inch through 24-inch shall be double strap.

Water service saddles for pipe sizes exceeding 24-inches shall be as specified by PWC Water Resources Engineering Department.

## **INSTALLATION**

### GENERAL



Pipe installation shall be in strict accordance with Specification Section 02222 – Excavation and Backfilling for Utility Systems and as outlined herein.

### PIPE INSTALLATION

Pipe installation shall be in accordance with the manufacturer's instructions. All pipes and fittings shall be handled to prevent damage to the protective coatings and linings.

All dust, dirt, oil, tar, or other foreign matter shall be cleaned from the jointing surfaces, and shall be lubricated with lubricant recommended by the manufacturer.

All pipe shall be installed in accordance with the approved drawings and cut sheets, unless otherwise directed by PWC.

All dead ends on new mains shall have a two (2) inch blow-off assembly as indicated on the approved drawings. The blow-off assembly shall be in accordance with PWC standard details.

For pipe sizes up to 12-inches, mechanical equipment should not be utilized to assemble the pipe. For pipe sizes over 12-inches, mechanical equipment may be utilized, in accordance with the pipe manufacturer's instructions. Any damage resulting from the use of mechanical equipment shall be replaced as directed by PWC.

Adjustments in grade by exerting force on the barrel of the pipe with excavating equipment shall not be allowed. The Contractor shall verify line and grade after assembling each joint.

When pipe installation is not in progress, the open ends of the pipe shall be closed by a water tight plug or other means approved by PWC Project Coordinator. If water is present, the plug shall remain in place until the water is lowered to a level that allows for proper installation. No pipe shall be laid in water or where in PWC Project Engineer's and/or PWC Project Coordinator's opinion trench conditions are unsuitable. Every precaution shall be taken to prevent material from entering the pipe while it is being installed.

### ALIGNMENT AND GRADE

The Contractor shall be responsible for installing the pipe and appurtenances to proper line and grade.

All ductile iron pipe and fittings shall be installed in accordance with ANSI/AWWA C-110/A21.10. All C-900 pipe shall be installed in accordance with ASTM D-2774. The amount of deflection in the PVC or ductile iron pipe shall not exceed the applicable AWWA standards and the manufacturer's recommendations. If the required deflection exceeds the specified limitations or as determined by the Public Works Commission, mechanical joint bends shall be utilized.

Pipe passing through walls of NCDOT bridges, retaining walls, and other concrete structures shall be factory restrained joint ductile iron and be installed in casings/sleeves in accordance with NCDOT specifications. Annular space between walls and sleeves shall be filled with an approved cement mortar that meets NCDOT specifications. The annular space between the sleeve and the pipe shall be filled with an approved mastic.

Pipe passing through the walls of meter vaults, valve pits, and storm drainage structures shall be restrained joint ductile iron, as specified by PWC. Pipe shall be installed in a casing/sleeve if determined to be necessary. Annular space between walls and sleeves shall be filled with an approved cement mortar. Annular space between pipe and sleeves shall be filled with an approved mastic. Proposed conflict boxes with storm and water shall be reviewed by PWC Water Resources Engineer and approved on a case by case basis.

All ductile iron pipe (regardless of diameter) within casings shall be factory restrained, in accordance with these specifications and the applicable PWC standard details. The use of mechanical restraints (i.e., mega-lugs, grip-rings, etc.) shall not be utilized on pipe within casings.

When pipe is field cut, the cut end shall be smooth and at right angles to the axis of the pipe. All sharp edges shall be removed. All field cut pipe shall be beveled. The beveled end of PVC pipe shall be removed, when installing into mechanical joint ductile iron fittings.

When connecting unlike (class, material, etc.) pipe, an approved PWC fitting shall be used. All pipe shall be installed in accordance with AWWA C-600 or C-605 as applicable, for buried lines and the manufacturer's recommendations. For mechanical joint pipe and fittings, all nuts shall be torqued to the manufacturer's recommendations.

Concrete thrust blocking shall be utilized on all PVC water mains. The concrete thrust blocking shall be in accordance with PWC standard details. When thrust blocking is to be utilized, backfilling shall not occur until the concrete has time to set. No hydrostatic pressure testing shall occur until the concrete thrust blocking has cured for a minimum of five (5) calendar days.

## FIRE HYDRANTS

Fire hydrants shall be installed as shown on the approved drawings. Each fire hydrant shall be connected to the main with a six (6) inch branch line and shall have a minimum of 42-inches of cover. Fittings between the valve and fire hydrant may be utilized, with prior approval from PWC. The valve shall be located at the main unless otherwise approved by PWC. Hydrants shall be set plumb with pumper nozzle facing the roadway. The hydrant branch shall not be backfilled until inspected and approved by PWC Project Coordinator. Fire hydrants shall be installed in accordance with PWC standard details.

## HYDROSTATIC TESTS

All mains and laterals shall be subjected to a hydrostatic pressure test. Each valved section maybe tested individually.

The Contractor shall furnish all labor and material, including test pumps, taps, and corporations, necessary to complete the work. Any taps which are not to be utilized shall be killed out at the main. If any taps are to be used for irrigation laterals they shall be installed in accordance with PWC standard details. A PWC Project Coordinator shall be present and observe all valve operation by the Contractor. Under no circumstances shall a Contractor operate any PWC-owned valves unless it is an emergency.

The duration of the pressure test shall be at least one hour or longer, as directed by PWC Project Coordinator. The hydrostatic pressure shall be 200 psi. The pipe to be tested shall be slowly filled with water and the specified test pressure shall be applied. Before applying the specified

test pressure, all air shall be expelled from the pipe. If hydrants or blow offs are not located to properly expel the air, taps shall be made as approved by PWC.

Damaged or defective materials discovered as a result of the pressure test shall be removed and replaced with new material, and the test shall be repeated until the test results are satisfactory to the Public Works Commission.

All replacement, repair or retesting shall be accomplished by the Contractor at no additional cost to the Public Works Commission. All repairs shall be reviewed and approved by PWC prior to backfill. The use of couplings, fittings, sleeves, etc. shall be reviewed and approved by PWC prior to use. The main must successfully pass the hydrostatic test prior to sterilization.

### STERILIZATION

Sterilization shall be in accordance with the requirements of NCDEQ, the North Carolina Rules Governing Public Water Supply, AWWA C651, and AWWA C655 (most recent editions). The Contractor shall furnish all chlorinating equipment, sterilization solution, materials, excavation, barricades, backfilling, and any taps and corporations necessary to complete the work. The Contractor shall fully cooperate with PWC Project Coordinator, furnish any needed assistance, and schedule the testing.

Prior to performing the hydrostatic test, water mains, laterals, and appurtenances shall be flushed to remove air, sediment, contaminants, and/or foreign matter. After completion of a successful hydrostatic test, the water system shall be disinfected by the thorough dispersion of a chlorine solution. The chlorine level shall be between 50 parts per million (ppm) and 100 ppm throughout the water system. In no case shall the chlorine level exceed 300 ppm. If the chlorine level is over 300 ppm, the system shall be completely flushed and re-chlorinated. **In no case shall chlorine be introduced into the water system in a dry solid state.**

The chlorine solution shall remain in contact with the interior surfaces of the water system for a minimum period of 24 hours and shall result in not less than 10 ppm of chlorine throughout the system. Then the water system shall be flushed with water from the existing PWC water system until the chlorine solution is dispelled. The Contractor shall take all necessary measures to prevent downstream erosion caused by flushing the lines. All erosion/damages shall be repaired at no additional expense to the Public Works Commission. All environmental regulations governing the release and/or disposal of chlorinated testing water shall be met by the Contractor. AWWA C655 defines "highly chlorinated" water as water having more than four (4) ppm. Any water with a chlorine level greater than four (4) ppm shall be de-chlorinated by the Contractor prior to being released to the environment.

If any disruption to the disinfection process occurs, or if any repair procedure is necessary then the disinfection process shall start over.

After disinfection, the water supply shall not be accepted or placed into service until bacteriological tests results or representative water samples analyzed in the Public Works Commission's laboratory are found to be satisfactory. The disinfection shall be repeated until tests indicate the absence of pollution for at least two (2) full days. PWC Project Coordinator shall be responsible for taking the sample(s) and transporting them to PWC laboratory.

If the initial sample taken after disinfection and flushing does not indicate that the water main is sterilized, the Contractor shall, in conjunction with PWC Project Coordinator, flush the lines. Once flushing is complete, another sample will be taken to the Public Works Commission's laboratory for analysis. Should this second sample also fail to indicate that the main is sterilized; the Contractor shall repeat the disinfection process. This process shall be repeated until the samples are satisfactory. The Contractor shall fully cooperate with PWC Project Coordinator, furnish any needed assistance, and schedule the testing.

**DIVISION 2  
SITE WORK  
02662 – FIRE HYDRANT PAINTING**

**GENERAL**

The object of these specifications is to provide the material and workmanship necessary to produce a first class job.

The Contractor shall paint all exposed exterior fire hydrant surfaces. Minor items not specifically specified, but necessary for proper completion of the work, shall be painted as directed by the Owner.

Painting shall be done at such times the Contractor and Engineer may agree upon in order that a dust free and neat work may be obtained. All painting shall be done in strict accordance with the paint manufacturer's recommendations and shall be satisfactory to the Engineer. Protective covering shall be utilized, as necessary and extreme care taken for protection of adjacent areas, equipment, shrubbery, or other items while painting is in progress. After painting is complete, all spilled paint drops, or other defects shall be removed from surfaces and the entire area thoroughly cleaned up. The Contractor shall submit to the Engineer, upon completion of the painting, certification from the paint manufacturer indicating that the quantity of paint, purchased for each item, was sufficient to properly coat all surfaces.

**PAINT**

All paint materials shall be first quality and shall be delivered on the job in the original sealed containers bearing the manufacturer's name and trademark. Paint shall conform to the requirements of Federal Spec. TT-V-51 or Military Spec. MIL-C450 or equal. The prime coat from the ground line up shall conform to Federal Spec. TT-P-86 (Type IV), Federal Spec. TT-P-636 or equal.

Thinners: Where thinning is necessary, only the products of the manufacturer furnishing the paint, and for the particular purpose, shall be allowed and all such thinning shall be done strictly in accordance with the manufacturer's instructions as well as with the full knowledge and approval of the Engineer.

**SURFACE PREPARATION**

All surfaces to be painted shall be prepared in a workman-like manner with the objective of obtaining a smooth, clean and dry surface. All painted surfaces shall be prepared and finished in accordance with the following specifications and shall be approved by the Engineer.

Metal: All exposed surfaces of fire hydrant and other ferrous metal items generally are to be shop primed and shall have all rust, scale, dust, grease or other deleterious substances removed by sandblasting or pickling in accordance with SSPC-SP-6. Cleaned metal shall be immediately primed to prevent new rusting. All ferrous metal items, not shop primed, shall be field cleaned by wire brushing (if approved by the Engineer) or sandblasting and immediately primed. Non-ferrous metals shall be solvent cleaned just prior to the application of prime coat or pre-treatment. Equipment not shop finished to the Engineer's satisfaction shall also be painted.

Application: Paint shall be applied evenly. Where necessary to obtain a smooth finish, the surface shall be sanded after application of the prime coat. Paint shall be applied, for each coat, at the rate specified by the manufacturer. Any difficulties in film thickness shall be corrected by the application of additional coats until the recommended thickness is obtained. If material has thickened or must be diluted for application by a spray gun, the coating shall be built-up to the same film thickness achieved with un diluted material. Additional coats of paint shall not be applied nor shall units be returned to service until paints are thoroughly dry. Paint shall not be applied in rain or damp weather or when the temperature is lower than 50°F. Painting shall be suspended when relative humidity exceeds 85% or when air temperature will drop to below 40°F within 18 hours of application.

### **PAINING SCHEDULE**

Schedule of colors and coating requirements are as follows: Acceptable dry mil thickness will be 4-6 for each coat. Bonnet of hydrant shall be Acrylic Enamel, Dark Green paint or approved equal. Fire hydrant barrel, caps, chain and other exterior surfaces shall be Quick Drying Acrylic Enamel Yellow Paint or approved equal.

**DIVISION 2  
SITE WORK  
02730 - SANITARY SEWER SYSTEMS**

**GENERAL**

Sanitary sewer lines and all appurtenant items shall be constructed of materials specified or indicated on the drawings. The intent and purpose of these specifications is to require a complete and satisfactory installation in every respect and any defect in material or workmanship shall be cause for the replacement and correction of such defect as directed by the Public Works Commission.

**RELATED SECTIONS**

- A. 02211 – Grading, Utilities
- B. 02222 – Excavation and Backfilling for Utility Systems
- C. 02732 – Sewage Force Mains

**MATERIALS**

**SEWER MAINS**

Prior to shipment each joint of pipe shall be stamped by an independent testing laboratory, certifying compliance with the specifications stated therein. Pipe sizes indicated shall be understood to be nominal inside diameter of the pipe. All sewer pipe materials shall be either PVC (as specified herein) or ductile iron (as specified herein), unless otherwise approved in writing by the Public Works Commission. Written approval shall be obtained prior to installation.

**DUCTILE IRON PIPE**

The raw material from all ductile iron pipe and fittings shall have an average minimum content consisting of 90% recycled iron and steel. Ductile iron pipe and fittings shall be manufactured in the United States of America in accordance with ANSI/AWWA A21.51/C151. The manufacturer of the ductile iron pipe shall be a member of the Ductile Iron Pipe Research Association (DIPRA).

All ductile iron pipe and fittings shall be in strict accordance with ANSI A21.51 and AWWA C151, Class 50 or Class 51, as applicable, in every respect. The working pressure shall be a minimum of 200 psi. Pipe shall be furnished in 18 or 20-foot lengths. All pipe joints used in open trench construction shall be furnished with "push-on" joints, unless otherwise indicated on the drawings or specified. All joints and fittings shall be in accordance with ANSI A21.11 and AWWA C111. All ductile iron interior surfaces shall be lined with two (2) coats of ceramic epoxy to produce a total minimum dry film thickness of 40 mils (Protecto401 or approved equal). The exterior pipe surfaces shall be protected with asphaltic coating as specified in AWWA C151 and C110. Specifications for the ceramic epoxy can be found in Specification Section 09802.

For aerial crossings which are 4 inches through 12 inches in diameter, manufactured restrained joint ductile iron pipe Class 53, or Class 53 flanged ductile iron pipe shall be utilized in accordance with the standard Public Works Commission detail for aerial crossings. Mega-lugs, field-lok, and gripper rings are not an allowable means of restraint for aerial crossings. For aerial crossings larger than 12 inches, or as noted specifically on the plans, flange joint ductile iron pipe, Class 53, shall be utilized in accordance with the standard Public Works Commission details. The location

of flanges shall be specifically designed for each application. The flange pipe shall be in accordance with ANSI/AWWA C-115/A21.15. Threads for threaded flange pipe shall be in accordance with ANSI B2.1, shop fabricated as outlined by AWWA 115 with serrated faces furnished on the pipe, completely factory installed. Welding of flanges to the body of the pipe will not be acceptable. Ductile iron fittings and flanges shall be in accordance with ANSI/AWWA C-110/A21.10 with a minimum working pressure of 250 psi. Gaskets shall be full faced SBR rubber per ANSI/AWWA C-111/A21.11 with a minimum 1/8" thickness. Linings and coatings shall be as outlined for ductile iron pipe.

If the Public Works Commission determines that an expansion coupling is required, it shall be installed as indicated on the drawings. The expansion coupling shall not be buried.

For subsurface water crossings (i.e., streams, wetlands), restrained joint ductile iron pipe shall be utilized. No mechanical restraint systems (e.g., mega-lugs, field-lok gaskets, etc.) shall be utilized. The pipe shall be installed in a casing, in accordance with the approved Public Works Commission detail, unless otherwise specifically approved by the Public Works Commission.

#### PVC PIPE

PVC sewer pipe and fittings 4 inches thru 15 inches shall be in accordance with ASTM D-3034 with a standard dimension ratio (SDR) of 26 for sewer mains and laterals. Larger diameter pipe (18 inches through 27 inches) shall be in accordance with ASTM F-679, with a SDR of 26. Both pipe and fittings shall be made of PVC plastic having a cell classification of 12454 as specified in ASTM D-1784.

Pipe joining shall be push on elastomeric gasket joints only and the joints shall be manufactured and assembled in accordance with ASTM D-3212. Elastomeric seals shall meet the requirements of ASTM F-477. The pipe shall be furnished with integral bells and with gaskets that are permanently installed at the factory and in accordance with ASTM D-3212 and contain a steel reinforcing ring. PVC sewer pipe shall be made by continuous extrusion of prime green unplasticized PVC and contain identification markings as required by the applicable ASTM standard.

#### SEWER FITTINGS

##### Ductile Iron Push-on Fittings:

Ductile iron sewer fittings on PVC mains shall be deep bell, gasketed joint, and air test rated. Gasket grooves shall be machined in the factory. Material shall be ductile iron, in accordance with ASTM A536, Grade 65-45-12 and ASTM F1336. Wall thickness shall meet the requirements of AWWA C153. Gaskets shall have a minimum cross sectional area of 0.20 square inches, and conform to ASTM F477. All ductile iron fittings shall have an interior coating of Protecto 401, or approved equal. All ductile iron fittings on PVC pipe shall provide a flow line that provides a smooth transition between the materials. Ductile iron fittings shall be as manufactured by the Harrington Corporation (Harco), or approved equal.

##### Mechanical Joint Fittings:

Joints shall be installed in accordance with AWWA C-600 and shall conform to AWWA Standard C-111. Mechanical joints shall be of the stuffing box type and shall conform to ANSI A21.11 for four inch (4") pipe and larger. Fittings and specials shall be ductile iron and shall be manufactured



in accordance with AWWA Standard C-110 (ANSI A21.11). Compact fittings shall be ductile iron in accordance with ANSI A 21.53 (AWWA C-153) for 4" thru 24" sizes only. Note: mechanical joint wyes are not included in the AWWA C-153 specification. Pressure rating shall be not less than 200 psi unless otherwise specified. All ductile iron fittings shall have an interior coating of Protecto 401, or approved equal. Mechanical joint fittings shall be utilized on ductile iron mains and ductile iron laterals. Mechanical joint fittings shall not be utilized on PVC mains, unless otherwise approved by the Public Works Commission.

#### PVC Fittings:

PVC fittings shall be manufactured in accordance with ASTM D-3034, F-1336, and F-679. Molded fittings shall be utilized in sizes from 4" to 8" (or larger, if available). Fabricated fittings shall only be utilized with prior approval from the Public Works Commission. Fabricated fittings are defined as those fittings that are made from pipe or a combination of pipe and molded components. All PVC fittings shall contain identification markings as required by the applicable ASTM standard. All PVC fittings shall be gasketed joint, except as indicated for interior drop structures. Plastic fittings shall be as manufactured by GPK Products, Inc., Plasti-Trends, the Harrington Corporation (Harco), or approved equal.

#### Ductile Iron Pipe Size x SDR26 Transition Adapter:

All ductile iron x PVC transition adapters shall be one (1) piece, bell x bell (gasket x gasket). Transition adapters shall range in size from four (4) inches through 12 inches. Transition adapters for pipe larger than 12-inches shall be as specified by the Public Works Commission. All transition adapters shall have a flow way tapered to allow a smooth transition between the ductile iron and PVC. Transition adapters shall be either PVC or ductile iron, in accordance with the following:

PVC – All PVC transition fittings shall be made from DR 18 C900 pipe stock. The C900 pipe stock shall meet the requirements of AWWA C900/C905, and have a minimum cell classification of 12454 as defined in ASTM D1784. The wall thickness shall meet or exceed DR 18. PVC transition fittings shall have SBR gaskets in accordance with ASTM F477. All six (6) inch and eight (8) inch adapters shall be molded. Molded fitting joints shall be 235 psi rated, in accordance with ASTM D3139, and shall have SBR rubber gaskets. Four (4) inch, ten (10) inch and 12 inch transition adapters shall have SBR Rieber style gaskets meeting ASTM F477. Joints shall be 235 psi rated, in accordance with ASTM D3139 for the C900 (ductile iron) bell, and in accordance with ASTM D3212 for the sewer (SRD26) bell. Molded C900 bell depths shall comply with AWWA C907. Fabricated (4-inch, 10-inch and 12-inch) bell depths and molded sewer (SDR26) bell depths shall be in accordance with ASTM F1336. PVC transition adapters shall be manufactured by the Harrington Corporation (Harco), GPK Products, or approved equal.

Ductile iron – Ductile iron transition fittings shall be deep bell, push-on joint, and air test rated. The ductile iron material shall comply with ASTM A536, Grade 65-45-12 or 80-55-06. The bell depth shall be in accordance with ASTM F1336. Gaskets shall be of SBR rubber, in accordance with ASTM F477. Transition gaskets are not allowed. All ductile iron transition fittings shall have an interior coating of Protecto401 or approved equal. Ductile iron transition fittings shall be manufactured by the Harrington Corporation (Harco) or approved equal.

#### Saddles:

Sewer service saddles may be utilized for sewer lateral installations. All sewer service saddles shall be ductile iron with stainless steel straps, bolts, nuts, and washers. The nuts shall be coated

to prevent galling. The saddle body shall be ductile iron, in accordance with ASTM A536, Grade 65-45-12. The gasket material shall be SBR, in accordance with ASTM D2000. Saddles for PVC or DI laterals shall have an alignment flange. Sewer service saddles shall be as manufactured by Geneco, or approved equal. All stainless steel straps shall be pre-formed at the factory, to the specified outside diameters of the pipe.

**SEWER LATERALS**

Ductile iron laterals – For ductile iron mains, utilize mechanical joint fittings or an approved saddle with an alignment flange (Geneco or approved equal). For PVC mains, utilize an approved saddle with an alignment flange (Geneco or approved equal) or ductile iron fittings as specified above.

PVC laterals – utilize a saddle with an alignment flange (Geneco or approved equal) on PVC or ductile iron mains; utilize a mechanical joint tee with SDR 35 transition gaskets on ductile iron mains; or utilize PVC fittings as specified above on PVC mains.

The following table summarizes the materials to be utilized for sewer main to lateral connections:

	<b>PVC Main</b>	<b>DI Main</b>
DI Lateral	DI fitting or approved saddle	MJ fitting or approved saddle
PVC Lateral	PVC fitting or approved saddle	MJ fitting with transition gasket or approved saddle

Sewer laterals shall be in accordance with these Specifications and PWC standard details S.10, S.11, and S.12.

**PRECAST CONCRETE MANHOLES**

Pre-cast circular reinforced concrete manhole units shall be in accordance with ASTM C-478. The tongue and groove ends of the manhole sections shall be manufactured for jointing with rubber gaskets (i.e., con-seal). An eccentric cone shall be utilized on all manholes, unless otherwise approved by the Public Works Commission.

Manhole steps shall be placed in all manholes and shall be steel reinforced (1/2" grade 60) copolymer polypropylene plastic steps in accordance with ASTM C-478 for material and design. The steps shall be spaced 16" on center with serrated treads and wide enough to stand on with both feet.

Manhole frames and covers shall be made of gray cast-iron, and the iron shall possess a tensile strength of not less than 18,000 psi. Cast iron shall conform to ASTM Specification A 48-83 Class 35. The frame and cover shall be manufactured by the same manufacturer. All castings shall be in accordance with Public Works Commission standard details. Any defective castings shall be removed and replaced.

Any special linings and coatings that are specified for a manhole and installed at the production facility, in the field, or during repairs, shall be applied in accordance with the applicable special coatings specification and the manufacturer’s specifications for that material.

Camlock ring and covers shall be in accordance with Public Works Commission standard details. Camlock bolt head shall be compatible with PWC standard tool for turning camlock mechanism. Camlock ring and covers shall be installed as indicated on the drawings, in accordance with PWC standard details.

#### **SELECT BEDDING MATERIAL**

Select bedding material shall be crushed stone (No. 57 or No. 5), in accordance with Public Works Commission standard details. Bedding material shall be provided for all pipe materials.

#### **INSTALLATION**

Pipe installation shall be in strict accordance with Specification Section 02222 – Excavation and Backfilling for Utility Systems and as outlined herein.

#### **PIPE LAYING**

Pipe installation shall be in accordance with the manufacturer's instructions. Proper equipment shall be utilized to perform the work in a manner satisfactory to PWC. All pipes and fittings shall be carefully lowered into the trench in such a manner to prevent damage to the protective coatings and linings. Under no circumstances shall pipe materials be dropped or dumped into the trench. Pipe shall be carried into position and not dragged.

All dust, dirt, oil, tar (other than standard coating), or other foreign matter shall be cleaned from the jointing surfaces, and the gasket, bell, and spigot shall be lubricated with lubricant recommended by the manufacturer.

The pipe shall be laid upgrade, beginning at the lower end with the tongue or spigot ends pointing in the direction of the flow to the correct line and grade, unless otherwise approved by PWC. The pipe section to be installed shall be aligned by batter board or laser beam with the last installed pipe section. Mechanical equipment should not be used to assemble the pipe. Pipe shall be assembled in accordance with the pipe manufacturer's instructions. Any damage resulting from the use of mechanical equipment shall be replaced as directed by PWC.

Adjustments in grade by exerting force on the barrel of the pipe with excavating equipment shall not be allowed. The Contractor shall verify line and grade after assembling each joint.

At any time when pipe laying is not in progress, the open ends of the pipe shall be closed by a water tight plug or other means approved by PWC Project Coordinator. If water is in the trench, the plug shall remain in place until the trench is pumped completely dry. No pipe shall be laid in water or where in PWC Project Engineer's and/or PWC Project Coordinator's opinion trench conditions are unsuitable. Every precaution shall be taken to prevent material from entering the pipe while it is being installed.

#### **ALIGNMENT AND GRADE**

All pipe shall be installed to the required lines and grades. Structures shall be installed at the required locations. The lines and grades of the pipe will generally be indicated by stakes parallel to the line of the pipe. The Contractor shall be responsible for installing the pipe to proper line and grade.

Pipe shall be visually inspected by shining a light between structures and /or by closed circuit television inspection. Any defects discovered, including poor alignment, shall be corrected as directed by the Public Works Commission.

The bottom of the trench shall be excavated to a minimum of four inches (4") below the outside bottom of the pipe being installed to allow adequate placement and compaction of bedding material prior to installation.

Select bedding material shall be placed a minimum of four inches (4") and a maximum of six inches (6") under the pipe for full width of the trench and halfway up the pipe on the sides. Bedding material shall be placed in layers not exceeding six inches (6") loose thickness for compacting by vibratory mechanical tamps under the haunches and concurrently on each side of the pipe for the full width of the trench. The final result shall be "Class B" bedding for rigid pipe. If the existing material under the pipe bedding material is unsuitable, the unsuitable material shall be removed and replaced with select bedding material (No. 57 or No. 5 stone), as authorized and approved by the Public Works Commission Project Coordinator.

The same material pipe shall be utilized from manhole to manhole, unless otherwise approved by PWC. If the section of pipe between manholes is 250 feet or less, no transitions will be allowed (either all PVC or all ductile iron). Should the length between manholes exceed 250 feet, only one transition will be allowed. Use of a C900 x SDR 26 adaptor shall be used to accomplish the transition. A transition is defined as the use of one C900 x SDR26 adaptor. No more than one (1) adaptor shall be utilized in any given manhole to manhole segment.

All manholes shall be constructed to Public Works Commission's standards. Installation shall be in accordance with ASTM C-891 and PWC standards.

Manholes shall be constructed of precast reinforced concrete circular sections installed on a base riser section with integral floor and shall be cored to accommodate the various pipe connections, as indicated on the drawings. Pipe connections to a manhole shall be by gasketed flexible watertight connections (boot for small diameter and A Loc for larger diameter pipe) or as approved by the Public Works Commission. The manhole size shall be in accordance with the following table, unless otherwise specified:

<u>Pipe Size</u>	<u>Manhole Diameter</u> **
24" and less	48" *
27" - 36"	60"
42" 72"	

\* Where interior drop structures are required, use 60" diameter as required in the Public Works Commission standard details.

\*\* Where multiple connections or acute angles are required, larger diameter manhole may be required as indicated on the plans.

The invert channel shall be constructed of brick and mortar, in accordance with Public Works Commission standard details. **Precast inverts are not allowed.** The invert channel shall be smooth and semicircular in shape conforming to the inside of the connecting sewer section. Changes in direction of flow shall be made with a smooth curve as large as a radius as the size of the manhole will permit without a decrease in flow velocity. Changes in size and grade of the channel shall be made gradually and evenly. The invert channel walls shall be constructed to

three quarters (3/4) of the height of the crown of the outlet sewer and in such a manner not to obstruct maintenance, inspection or flow in the sewers. The inverts shall have a minimum slope of one (1) percent across the bottom of the manhole. A shelf shall be provided on each side of any manhole invert channel. Inverts in manholes with standing water will not be acceptable. The shelf shall be sloped not less than 1:12 (min) and no more than 2:12 (max). The bottom of the boot for the new sewer main or lateral shall be set one inch above existing shelf unless otherwise indicated.

When used in a paved street, the ring and cover shall be set in suitable mortar surrounded by a concrete collar in accordance with Public Works Commission standard details. When used in places other than in a paved street, the ring and cover shall be set to the grade shown on the plans or directed by the Public Works Commission. In unpaved areas cam-lock ring and cover shall be used. Camlock ring and cover shall be installed in accordance with Public Works Commission standard details.

The interior manhole riser joints, lift holes and grade adjustment rings shall be sealed with non-shrinking mortar to provide a watertight manhole. Lift holes sealed by the manufacturer with plastic caps do not require mortar seal. The hardened mortar shall be smooth to rub with no sharp edges. Use of grade rings with cam-lock ring and cover are not allowed, unless approved by PWC Project Coordinator. **Use of grade rings is not allowed for above grade adjustments.**

All exterior manhole riser joints, including the joint at the cone, shall be sealed with an external rubber sleeve. The sleeve shall be made of stretchable, self-shrinking rubber, with a minimum thickness of 30 mils. The back side of each wrap shall be coated with a cross-linked reinforced butyl adhesive. The butyl adhesive shall be a non-hardening sealant, with a minimum thickness of 30 mils. The seal shall be designed to stretch around the manhole joint and then overlap to create a fused bond between the rubber and butyl adhesive. The application shall form a continuous rubber seal for the life of the application. The sealing system shall be as manufactured by Concrete Sealants, Inc. (Con-Seal), Sealing Systems, Inc., or approved equal. The wrap shall be a minimum of six (6) inches in width, and shall be centered on the joint. All manhole joints (including the cone section to the last riser) shall be wrapped and sealed. Care shall be taken to prevent damage to the wrap during backfill operations. The manhole surface shall be prepared in accordance with manufacturer's specifications, prior to installing the joint wrap.

Materials shall not enter the sewer line during construction of the manhole. The manhole shall be kept clean of any and all debris or materials. Any debris or material that entered the manhole shall be immediately removed. This condition shall be maintained until final acceptance of the work.

#### CONNECTION TO EXISTING MANHOLES OR LIFT STATIONS

All connections to existing manholes and/or lift stations shall be approved by the Public Works Commission. Where new mains are to be connected to existing active sanitary sewers, the active sewers shall remain in service. Unless otherwise indicated, where new lines are connected into existing manholes, all or such portion of the manhole invert as is necessary shall be removed and a new invert shall be constructed to accommodate both new and existing flows. All work shall conform to the requirements specified for new manholes. The existing structure connection shall be cored and a flexible watertight connection (i.e., boot) installed. The boot shall be installed in accordance with Public Works Commission standard details and requirements. The Contractor shall coordinate and cooperate with the Public Works Commission's Project Coordinator.

## PIPE TO MANHOLE CONNECTOR (BOOT)

A watertight, flexible pipe-to-manhole connector shall be utilized on all pipe to manhole connections, for both new and existing manholes and pipes, unless otherwise specifically authorized in writing by the Public Works Commission.

The connector assembly shall be the sole element to provide a watertight seal of the pipe to the manhole or other structure. The connector shall consist of a rubber gasket, an internal compression sleeve, and one or more external take-up clamps. The connector shall consist of natural or synthetic rubber and Series 300 non-magnetic stainless steel. No plastic components shall be allowed.

The rubber gasket shall be constructed of synthetic or natural rubber, and shall meet or exceed the requirements of ASTM C-923. The connector shall have a minimum tensile strength of 1,600 psi. The minimum cross-sectional thickness shall be 0.275 inches.

The internal expansion sleeve shall be comprised of Series 300 non-magnetic stainless steel. No welds shall be utilized in its construction.

Installation of the connector shall be performed utilizing a calibrated installation tool furnished by the connector manufacturer. Installation shall require no re-tightening after the initial installation. Installation shall be done in accordance with the manufacturer's instructions.

The external compression take-up clamps shall be Series 300 non-magnetic stainless steel. No welds shall be utilized in its construction. The clamps shall be installed utilizing a torque-setting wrench furnished by the connector manufacturer. Installation shall be done in accordance with the manufacturer's instructions.

The Contractor shall utilize the proper size connector in accordance with the connector manufacturer's recommendations. All dead-end pipe stubs shall be restrained in accordance with ASTM C-923.

The finished connection shall provide a sealing to a minimum of 13 psi, and shall accommodate a minimum pipe deflection of seven (7) degrees without the loss of seal.

The pipe to manhole connector shall be PSX: Direct Drive as manufactured by Press-Seal, or approved equal.

## INSIDE DROP MANHOLE STRUCTURE

Inside manhole drop structures shall be constructed and installed in accordance with Public Works Commission standard details.

## CLEANING

Prior to final inspection, all sanitary sewer laterals, mains, and manholes newly installed on the collection system shall be flushed and cleaned. During the flushing operation, the downstream manhole shall be closed with a watertight plug to protect the existing sewer main. All water and debris shall be removed and properly disposed of by the Contractor. This condition shall be maintained until the Public Works Commission issues final acceptance for the project.

## TESTING

Completed sewers shall be tested in accordance with the provisions outlined below. The Contractor shall furnish all equipment, labor, materials, and pay all costs associated with the tests performed. The Contractor shall schedule all testing with the Public Works Commission's Project Coordinator, a minimum of 48 hours in advance. The Contractor shall cooperate with the Public Works Commission's Project Coordinator and furnish any needed assistance necessary to complete the required testing.

For annexation and/or retrofit projects: No testing shall be conducted prior to successful completion of the compaction testing.

For all other projects: No testing shall be completed until all utilities are installed, prior to preparation of the road subgrade. The Contractor may elect to perform testing to satisfy them that the sewer utility is installed properly prior to commencing installation of other utilities. However, such testing shall not be construed as acceptance by PWC.

The deflection/mandrel test shall not be performed until a minimum of thirty (30) calendar days after backfill operations are completed and the area graded to final contours. In lieu of waiting thirty (30) calendar days, the Contractor has the option to have an independent testing laboratory verify that compaction has been completed to achieve the maximum density as shown in the detail. The location and elevation of the compaction testing shall be determined reviewed and approved by the Public Works Commission's Project Coordinator. The Contractor shall provide the Public Works Commission with a copy of the density testing results.

Compaction testing shall be done in accordance with Specification Section 02222 – Excavation and Backfilling for Utility Systems.

### Vacuum Testing Manholes:

All precast sanitary sewer manholes installed by the Contractor shall be vacuum tested for leakage. This test shall be done in accordance with ASTM C-1244 and in the presence of a Public Works Commission Project Coordinator. The Contractor shall be responsible for providing all the necessary labor, materials, equipment, testing apparatus, and all other incidentals necessary to complete the vacuum test. All testing equipment utilized shall be approved for use in vacuum testing manholes.

Each manhole shall be tested after assembly. All lift holes shall be plugged with an approved non-shrink grout. All lines, including laterals, entering the manhole shall be temporarily plugged. The Contractor should take care to ensure that the pipes and plugs are secure in place to prevent them being drawn into the manhole. The test head shall be placed directly on top of the concrete surface of the manhole following the manufacturer's recommendations, rather than to the cast iron seating ring.

Manholes may be tested either prior to backfill or post backfill at the contractor's option. For pre-backfill testing, a vacuum of 10 inches of Mercury (inches Hg) shall be drawn on the manhole, the valve on the vacuum line of the test head closed, and the vacuum pump shut off. The time shall be measured for the vacuum to drop to 9 inches of Mercury (inches Hg). The manhole is acceptable if the time for the vacuum reading to drop from 10 inches of Mercury to 9 inches of Mercury meets or exceeds the values indicated below:

#### **Diameter of Manhole**

<b><u>Manhole Depth</u></b>	<b><u>4' Diameter</u></b>	<b><u>5' Diameter</u></b>	<b><u>6' Diameter</u></b>
<b>10' or less</b>	<b>25 sec</b>	<b>33 sec</b>	<b>41 sec</b>
<b>11' to 15'</b>	<b>38 sec</b>	<b>49 sec</b>	<b>62 sec</b>
<b>16' to 20'</b>	<b>50 sec</b>	<b>65 sec</b>	<b>81 sec</b>
<b>21' to 25'</b>	<b>62 sec</b>	<b>82 sec</b>	<b>101 sec</b>
<b>25' to 30'</b>	<b>74 sec</b>	<b>98 sec</b>	<b>121 sec</b>

Vacuum testing backfilled manholes is not recommended in the presence of groundwater. Vacuum testing a backfilled manhole that is subjected to hydrostatic pressure may exceed the design limits of the flexible connectors and could lead to failure of the structure, joints, and/or connectors. Where groundwater is present a reduction in the vacuum pressure applied to the manhole will be required. The vacuum shall be reduced by 1 inch of Mercury for every 1 foot of hydrostatic head between 12 feet and 21 feet. A vacuum test should not be performed when the hydrostatic head exceeds 22 feet. See the chart below:

Hydrostatic Head (ft)*	12	13	14	15	16	17	18	19	20	21	22
Vacuum Pressure (in Hg)	10	9	8	7	6	5	4	3	2	1	**

\*Hydrostatic head above the critical connector (critical connector is bottom most flexible connector)

\*\*Do not perform vacuum test

If the manhole fails the initial test, the manhole shall be repaired by an approved method until a satisfactory test is obtained. All repair methods shall be approved by the Public Works Commission prior to being utilized. Retesting shall be performed until a satisfactory test is accomplished.

#### Mandrel Testing:

Deflection tests shall be performed on all PVC pipe installations. PVC pipe's maximum deflection after backfilling shall not exceed five (5) percent. The rigid ball or mandrel used for the deflection test shall have a diameter not less than 95 percent of the base inside diameter or average inside diameter of the pipe depending on the type of pipe manufactured and the applicable ASTM Standard. The PVC pipe shall be measured in compliance with ASTM D2122 "Standard Test Method of Determining Dimensions of Thermoplastic Pipe and Fittings". The Contractor shall supply all labor, equipment and materials necessary to perform the test in the presence of the Public Works Commission's Project Coordinator. The test shall be performed without mechanical pulling devices. The mandrel shall be constructed so as to preclude any yield in diameter, and with a pull line on each end to facilitate withdrawal. If the deflection exceeds the allowable, the Contractor shall remove and replace the pipe.

#### Air Testing:

Air testing shall be performed on all mains and laterals to determine acceptability. The length of sewer subject to an air test shall be the distance between two adjacent manholes. The tests shall be conducted in accordance with the appropriate ASTM standard. The air test shall be coordinated with the Public Works Commission. The Contractor is required to supply all equipment, labor, materials and pay all costs associated with the test performed.



## Air Test for PVC Pipe

The low pressure air test on PVC pipe shall be performed with satisfactory results in accordance with ASTM F1417 "Standard Test Method for Installation Acceptance of Plastic Gravity Sewer Lines Using Low-Pressure Air". The pipe, including lateral assemblies, shall be plugged and air added slowly until the internal pressure of the line is raised to 4.0 psi. After the pressure of 4.0 psi is obtained, regulate the air-supply so that the pressure is maintained between 3.5 and 4.0 psi for at least two (2) minutes, depending on air/ground temperature conditions. The pressure will drop slightly until equilibrium is obtained; however, a minimum of 3.5 psi is required. Once the 3.5 psi is maintained, the test will begin. If the pressure drops 1.0 psi within the time indicated below, the test fails.

<b>Pipe Dia. (in)</b>	<b>Minimum Time (minutes)</b>	<b>Length for Min Time (ft)</b>	<b>Time for Longer Length (sec)</b>
4	3:46	597	0.380L
6	5:40	398	0.854L
8	7:34	298	1.520L
10	9:26	239	2.374L
12	11:20	199	3.418L
15	14:10	159	5.342L
18	17:00	133	7.692L
21	19:50	114	10.470L
24	22:40	99	13.674L
27	25:30	88	17.306L
30	28:20	80	21.366L
33	31:10	72	25.852L
36	34:00	66	30.768L

The Contractor shall observe all safety precautions to include allowing no one in the manholes during testing, securing all plugs and providing additional plug bracing. The Contractor shall be required to furnish, install and remove after testing at no additional cost, a temporary glue cap/plug to be airtight for all cleanout stacks to accomplish air testing. The air pressure shall never exceed 8 psi. All gauges shall be accessible outside of the manholes.

## HYDROSTATIC TESTS

After the ductile iron sewer pipe has been laid within the "protected" area and backfilled to finished grade, the pipe shall be subjected to a hydrostatic pressure test. All laterals within the "protected" area shall be ductile iron. All sewers subject to hydrostatic testing shall include (1) sewers entering or crossing streams, (2) sewers located less than 100 feet from any public or private water supply source including any WS-I waters or Class I or Class II impounded reservoirs, (3) where the minimum 18 inch vertical and 10 feet horizontal separation cannot be maintained between sewers and water mains (see NC DENR Regulations), or (4) as specified and/or indicated on the drawings. The Contractor will furnish all labor and material, including test pumps, plugs, and all other incidentals for making hydrostatic tests. Hydrostatic pressure testing shall be conducted on the completed main, including the laterals.

The duration of the pressure test shall be at least one hour or longer, as directed by the Public Works Commission. The hydrostatic pressure shall be 150 psi. Each section of pipe shall be

slowly filled with water and the specified test pressure based on the elevation of the lowest point of the line or section under test and corrected to the elevation of the test gauge, shall be applied by means of a pump connected to the pipe in a manner satisfactory to the Public Works Commission. Before applying the specified test pressure, all air shall be expelled from the pipe.

All joints showing visible leaks shall be made tight. Cracked or defective pipe, joints, laterals, and fittings discovered in consequence of the pressure test shall be removed and replaced with sound material, and the test shall be repeated until the test results are satisfactory. The requirement for the joints to remain exposed for the hydrostatic test may be waived by the Public Works Commission in certain situations. The test shall be repeated until satisfactory to the Public Works Commission.

The results of the pressure tests shall be satisfactory as specified. All replacement, repair, or retesting shall be accomplished by the Contractor. All repairs shall be reviewed and approved by the Public Works Commission prior to backfill. The use of couplings, sleeves, etc. shall be reviewed and approved by the Public Works Commission prior to use.

**DIVISION 2  
SITE WORK  
02732 – SEWER FORCE MAINS**

**GENERAL**

Sewage force mains and all appurtenant items shall be constructed of materials as specified or indicated on the drawings. The intent and purpose of these specifications is to require a complete and satisfactory installation in every respect and any defect in material or workmanship shall be cause for replacement and correction of such defect as directed by the Public Works Commission and at no expense to the Public Works Commission. All materials and workmanship shall be in complete accordance with the standards and specifications of the Public Works Commission and subject to Public Works Commission inspection and approval.

**RELATED SECTIONS**

- A. Section 02222 – Excavation and Backfilling for Utility Systems
- B. Section 02660 – Water Distribution
- C. Section 02730 – Sanitary Sewer System
- D. Section 02736 – High Density Polyethylene Pipe
- E. Section 02753 – Submersible Lift Stations
- F. Section 02754 – Self-Priming Lift Stations
- G. Section 09801 – Special Coatings – Anti-Microbial Admixture
- H. Section 09802 – Special Coatings – Ceramic Epoxy

**MATERIALS**

**PVC PIPE**

In order to prevent the sanitary sewer force main from being mistaken for a water main, **all force main PVC pipe shall be green in color.**

Two (2) inch PVC pipe shall be manufactured using Grade 1 PVC compound material as defined in ASTM D-1784 and shall be SDR21, pressure class 200 in accordance with ASTM D 2241 or SDR-17 with a pressure rating of 250 psi, in accordance with ASTM D-2241. Fittings for two (2) inch PVC shall be solvent welded Schedule 80 PVC. The pipe shall be plainly marked with the manufacturer's name, size, material (PVC) type and grade or compound, NSF seal, pressure rating and reference to appropriate product standards.

All PVC pipe four (4) inches through 12 inches and couplings shall be manufactured using virgin compounds as defined in ASTM D-1784, with a 4000 psi HDB rating and designated as PVC 1120 to be in strict accordance with AWWA C-900. The pipe shall be Class 150 and conform to the thickness requirements of DR18. The pipe and fittings shall be manufactured to withstand 755 psi quick burst pressure tested in accordance with ASTM D-1599 and withstand 500 psi for a minimum of 1,000 hours tested in accordance with ASTM D-1598. Couplings shall be compression, twin gasket type in accordance with ASTM D-3139 for push-on joints and ASTM F-477 for elastomeric seals (gaskets). PVC fittings are not acceptable for mains other than two (2) inch. The pipe joints shall be of the integral bell type with rubber gaskets shall conform to the requirements of ASTM D-3139 or ASTM F-477. Fittings and specials for mains four (4) inches and larger shall be ductile iron, bell end in accordance with AWWA C-110, 200-psi pressure rating unless otherwise shown or specified, except that profile of bell may have specials of the

same material as the pipe with elastomeric-gaskets, all in conformance with the requirements of AWWA C-900. Ductile iron fittings to PVC pipe shall be adequately supported on a firm trench foundation. Fittings shall be for bell and spigot pipe or plain end pipe, or as applicable.

**Mechanical restraining systems shall not be used on PVC pipe.**

## DUCTILE IRON PIPE

The raw material from all ductile iron pipe and fittings shall have an average minimum content consisting of 90% recycled iron and steel. Ductile iron pipe and fittings shall be manufactured in the United States of America in accordance with ANSI/AWWA A21.51/C151. The manufacturer of the ductile iron pipe shall be a member of the Ductile Iron Pipe Research Association (DIPRA).

All ductile iron pipe and fittings (six (6) inches and above) shall be in strict accordance with ANSI/AWWA C-150/A21.50 and ANSI/AWWA C-151/A21.51, Class 50 in every respect. Four (4) inch ductile iron pipe shall be Class 51. Joints shall be mechanical joint or push on joint as specified and installed in accordance with AWWA C-600 and shall conform to AWWA Standard C-111. Mechanical joints shall be of the stuffing box type and shall conform to ANSI A21.11 for four (4) inch pipe through 12-inch pipe. Push on joints, rubber gaskets and lubricant shall conform to ANSI A21.11. Fittings and specials shall be ductile iron and shall be manufactured in accordance with AWWA Standard C-110 (ANSI A21.11).

Compact fittings shall be mechanically restrained, ductile iron in accordance with ANSI A 21.53 (AWWA C-153) for four (4) inch through 12-inch sizes only. Where thrust blocking is utilized, fittings shall be full body ductile iron in accordance with ANSI A 21.53 (AWWA C110). Pressure rating shall be not less than 200 psi unless otherwise specified. All ductile iron interior surfaces shall be lined with two (2) coats of ceramic epoxy to produce a total minimum dry film thickness of 40 mils (Protecto401 or approved equal). The exterior pipe surfaces shall be protected with asphaltic coating as specified in AWWA C151 and C110. Specifications for the ceramic epoxy can be found in Specification Section 09802.

All pipe joints within an encasement shall be furnished with manufactured restrained joints, and as specified in the standard Public Works Commission detail for encasements.

For aerial crossings which are four (4) inches through 12 inches in diameter, manufactured restrained joint ductile iron pipe Class 53, or Class 53 flanged ductile iron pipe shall be utilized in accordance with the standard Public Works Commission detail for aerial crossings. Mega-lugs, field-lok, and gripper rings are not an allowable means of restraint for aerial crossings. For aerial crossings larger than 12 inches, or as noted specifically on the plans, flange joint ductile iron pipe, Class 53, shall be utilized in accordance with the standard Public Works Commission details. The location of flanges shall be specifically designed for each application. The flange pipe shall be in accordance with ANSI/AWWA C-115/A21.15. Threads for threaded flange pipe shall be in accordance with ANSI B2.1, shop fabricated as outlined by AWWA 115 with serrated faces furnished on the pipe, completely factory installed. Welding of flanges to the body of the pipe will not be acceptable. Ductile iron fittings and flanges shall be in accordance with ANSI/AWWA C-110/A21.10 with a minimum working pressure of 250 psi. Gaskets shall be full faced SBR rubber per ANSI/AWWA C-111/A21.11 with a minimum 1/8" thickness. Linings and coatings shall be as outlined for ductile iron pipe.

If the Public Works Commission determines that an expansion coupling is required, it shall be installed as indicated on the drawings. The expansion coupling shall not be buried.

For subsurface water crossings (i.e., streams, wetlands), restrained joint ductile iron pipe shall be utilized. No mechanical restraint systems (e.g., mega-lugs, field-lok gaskets, etc.) shall be utilized. The pipe shall be installed in a casing, in accordance with the approved Public Works Commission detail, unless otherwise specifically approved by the Public Works Commission.

Transition between ductile iron pipe and HDPE shall be accomplished utilizing mechanical restraints as approved by PWC.

### HDPE PIPE

All high density polyethylene (HDPE) pipe and fittings shall be in accordance with PWC Standard Specification Section 02736, most recent edition.

### COMBINATION AIR RELIEF AND VACUUM VALVE ASSEMBLIES

All sewer force mains shall have automatic air release valves installed as indicated on the plans, and in accordance with Public Works Commission requirements. The automatic air release valve shall be a combination air release valve. Combination air release valves shall be heavy duty "universal" style, single body units, incorporating the functions of an air and vacuum valve within a single housing.

The tap size shall be a minimum of two (2) inches, however if a larger tap is needed it shall be sized accordingly. The valve body, cover flange, and all internal parts shall be 316 stainless steel. The air release orifice shall be as specified by the Design Engineer. The air release valve shall have a maximum working pressure of 200 psi.

All air and vacuum combination release valves shall be Crispin Model UX20, ARI D-020, H-Tec Model 986, or approved equal. All air release valves shall be installed in accordance with the manufacturer's recommendations.

Air relief and vacuum valve manholes shall be 60 inch diameter precast concrete units conforming to ASTM C-478. The combination air relief vacuum valve manhole shall be cast with an anti-microbial admixture, in accordance with manufacturer's instructions. The manholes and valves shall be installed in accordance with the standard PWC detail. The force main shall consist of one full joint of PVC C-900 (DR18) pipe centered at the air relief valve and a minimum of four (4) feet deep.

Combination air relief and vacuum valves shall be installed using stainless steel double strap service saddles, a two (2) inch ball valve, and a two (2) inch x one (1) inch brass tee with a quick connect attachment as shown in PWC standard detail.

Service saddles for two (2) inch taps on four (4) inch and larger size iron pipe shall be ductile iron with stainless steel double straps, bolts, nuts and washers

Ball valves shall be all bronze construction, with a handle operator. Ball valves shall be manufactured and tested in accordance with AWWA/ANSI C800. The valve shall be equipped with packing nut, gland, and packing material. Ball valves shall be of an approved type made from approved materials conforming to ASTM specifications and shall also meet the approval of PWC. The turn required to travel from fully closed to fully open on a ball valve shall be 90 degrees.

## AIR RELEASE VALVE MANHOLE RING AND COVER

Cast iron manhole frames and covers shall conform to the drawings in all essentials of design with vent holes. The frames and covers shall have a combined weight of not less than 310 pounds and shall conform to ASTM A-48, Class 30 frame and Class 35 cover. Lettering on the cover shall conform to the City of Fayetteville Public Works Commission standards and shall be stamped or cast into all covers so as to be plainly visible. Unless otherwise shown on the drawings, the frames and covers shall be so set that the top of the cover will be flush with finished grade or as directed by PWC.

## BY-PASS PUMPING ASSEMBLIES

By-pass pumping assemblies shall be installed in accordance with PWC standard detail S.21. The bypass pumping assembly shall be constructed of ductile iron pipe which meets the requirements of this specification.

## INSTALLATION

Pipe installation shall be in strict accordance with Specification Section 02222 – Excavation and Backfilling for Utilities Systems, and as outlined herein.

## PIPE LAYING

Pipe installation shall be in accordance with the manufacturer's instructions. Proper equipment shall be utilized to perform the work in a manner satisfactory to PWC. All pipes and fittings shall be carefully lowered into the trench in such a manner to prevent damage to the protective coatings and linings. Under no circumstances shall pipe materials be dropped or dumped into the trench. Pipe shall be carried into position and not dragged.

All dust, dirt, oil, tar (other than standard coating), or other foreign matter shall be cleaned from the jointing surfaces, and the gasket, bell, and spigot shall be lubricated with lubricant recommended by the manufacturer.

Mechanical equipment should not be used to assemble the pipe. Pipe shall be assembled in accordance with the pipe manufacturer's instructions. Any damage resulting from the use of mechanical equipment shall be replaced as directed by PWC.

Adjustments in grade by exerting force on the barrel of the pipe with excavating equipment shall not be allowed. The Contractor shall verify line and grade after assembling each joint.

At any time when pipe laying is not in progress, the open ends of the pipe shall be closed by a water tight plug or other means approved by PWC Project Coordinator. If water is in the trench, the plug shall remain in place until the trench is pumped completely dry. No pipe shall be laid in water or where in PWC Project Engineer's and/or PWC Project Coordinator's opinion trench conditions are unsuitable. Every precaution shall be taken to prevent material from entering the pipe while it is being installed.

## ALIGNMENT AND GRADE

All pipe shall be installed to the required lines and grades. Structures shall be installed at the required locations. The lines and grades of the pipe will generally be indicated by stakes parallel to the line of the pipe. The Contractor shall be responsible for installing the pipe to proper line and grade.

Threaded PVC and cemented joints will not be permitted. The ends of push on joints shall be beveled to facilitate assembly. Pipe shall be marked to indicate when the pipe is fully seated and the gasket lubricated to prevent displacement. Care shall be exercised to insure that the gasket remains in proper position in the bell or coupling while marking the joint.

All pipe installations shall be properly restrained, utilizing either thrust blocks or approved restraint systems. The thrust blocking shall be in accordance with PWC standards, and as designed by the Engineer. The approved restraint system shall be installed in accordance with the manufacturer's instructions. For the purpose of identification of buried pipes during future trenching or location, a continuous "detectable" identification wire shall be installed as well as green, "Sanitary Sewer Force Main" marking tape. The wire shall be a minimum 12 gauge single strand, coated copper wire or copper clad steel wire that is suitable for underground use. The wire shall be buried continuously along the pipe. The wire shall be "stubbed" into marker posts and air release valve manholes and secured such that a "direct"/conductive metal detector may be used to trace the pipe location.

The marker posts shall be Rhino TriView TracerPeds which are green with a "Sewer Force Main" warning decal (GD-5314K) and have internal terminals. The marker posts shall utilize the TriGrip Anchor system for direct bury installations. The identification wire shall be attached to the marker posts in accordance with PWC standards. Tracing wire marker posts shall be located no more than 500 feet apart.

When the force main is located in unpaved areas such as easements the marker posts shall be installed along the centerline of the force main. When the force main is located in paved areas the marker posts may be offset from the centerline of the force main in a uniform manner. The wire shall be installed with all non-metallic pipelines.

The "Sanitary Sewer Force Main" marking tape shall be green and labeled to warn of the presence of the sewer main. The tape shall be manufactured for durability and resistance to the elements. The marking tape shall be installed with both PVC and ductile iron force mains.

### **CONNECTION TO EXISTING MANHOLES**

Where new mains are to be connected to existing active sanitary sewers, the active sewers shall remain in service by the Contractor. Unless otherwise indicated, where new lines are connected into existing manholes, all or such portion of the manhole invert as is necessary in the opinion of PWC Project Coordinator shall be removed and a new invert shall be constructed to accommodate both new and existing effluent pipes and flows. Where force mains enter manholes, pipe and fittings shall be restrained as indicated on the plans with the force main outlet directed toward invert out.

All work shall conform to the applicable requirements specified for new manholes including all necessary concrete works, brick work, cutting, shaping and pipe fitting. Existing manhole walls, inverts, and shelves shall be coated with cement mixed with an anti-microbial additive in accordance with Specification Section 09801. New manholes that contain a force main discharge shall be cast with an anti-microbial admixture, in accordance with Specification Section

09801. The Contractor shall coordinate and cooperate with the Public Works Commission Project Coordinator on all connections. Connections to any manhole shall be made using the core and boot method. If necessary, drop or slide structures shall be installed, in accordance with PWC standards.

### **HYDROSTATIC TESTS**

After the pipe has been laid, the valves installed, the taps made and the system has been partially backfilled as specified, all newly laid pipe shall be subjected to a hydrostatic pressure test. Where any section of a force main is provided with concrete thrust blocking for fittings, the hydrostatic test shall not be made until at least five (5) days after installation of the blocking unless otherwise approved. The Contractor will furnish all labor and material, including test pumps, taps, and corporations, for making hydrostatic tests. Cost for said tests shall be included in the Proposal. A PWC Project Coordinator shall be present for all testing. The Contractor shall coordinate with PWC Project Coordinator for disposing of the test water from the system.

The duration of the pressure test shall be at least one hour or longer, as directed by PWC Project Coordinator. The hydrostatic pressure shall be 200 psi. The pipe shall be slowly filled with water and the specified test pressure based on the elevation of the lowest point of the line or section under test and corrected to the elevation of the test gauge, shall be applied by means of a pump connected to the pipe in a manner satisfactory to PWC Project Coordinator. Before applying the specified test pressure, all air shall be expelled from the pipe. If blow offs are not available at the high places, taps shall be made to provide blow offs.

The results of the pressure test shall be satisfactory as specified. All replacement, repair or retesting shall be accomplished by the Contractor at no additional cost to PWC. All materials and methods used to make repairs shall be approved by PWC. PWC Project Coordinator shall be present while all repair work is taking place.



**DIVISION 2  
SITE WORK  
02736 HIGH DENSITY POLYETHYLENE PIPE**

**GENERAL**

The purpose of this specification is to outline the requirements to furnish, install, and test high density polyethylene pipe and fittings. The Contractor shall furnish all labor, materials, equipment, and incidentals necessary to install the HDPE pipe in accordance with the Contract Drawings and as specified herein.

**REFERENCES**

The following ASTM Standards are incorporated by reference into this specification. The latest edition of the reference shall be used.

- A. D 1248 Standard Specification for Polyethylene Plastics Molding and Extrusion Materials
- B. D 1603 Standard Test Method for Carbon Black in Olefin Plastic
- C. D 2122 Standard Test Method for Determining Dimensions of Thermoplastic Pipe and Fittings
- D. D 2657 Standard Practice for Heat Fusion Joining of Polyolefin Pipe and Fittings
- E. D 3350 Standard Specification for Polyethylene Plastics Pipe and Fittings Materials
- F. F 714 Specification for Polyethylene Plastic Pipe Based on Outside Diameter

In case of conflicting requirements between this specification and these referenced documents, this specification will govern.

**SUBMITTALS**

The Contractor shall furnish prior to use of the materials, satisfactory written certification of his compliance with the manufacturer's standards for all materials, conformance with the methods of the manufacturer, and accordance with all standards specified and referenced herein.

**RELATED SECTIONS**

- I. Section 02302 – Horizontal Directional Drilling
- J. Section 02660 – Water Distribution
- K. Section 02730 – Sanitary Sewer System
- L. Section 02732 – Sewage Force Mains
- M. Section 02750 – Wastewater Flow Control (Bypass Pumping)
- N. Section 02760 – Television Inspection

**QUALITY ASSURANCE**

- A. The HDPE pipe shall be furnished by manufacturers who are fully experienced, reputable, and qualified in the manufacture of the HDPE pipe to be furnished. The pipe shall be designed, constructed, and installed in accordance with the best practices and methods and shall comply with this specification section.
- B. All HDPE pipe and fittings shall be from a single manufacturer. The supplier shall be

responsible for the provisions of all test requirements as specified. In addition, all HDPE pipe to be installed may be inspected at the plant for compliance with these specifications by an independent testing laboratory acceptable to Fayetteville Public Works Commission(PWC). The Contractor shall require the manufacturer's cooperation in these inspections. The cost of the plant inspection shall be the responsibility of the Contractor.

- C. Inspection of the pipe may be made by any representative of PWC after delivery. The pipe shall be subject to rejection at any time on account of failure to meet any of the requirements specified, even though sample pipes may have been accepted as satisfactory at the place of manufacture. Pipe rejected after delivery shall be identified as such, and shall be immediately removed from the job site.
- D. The physical appearance of the HDPE pipe having deformities such as concentrated ridges, discoloration, excessive spot roughness, pitting, varying wall thickness, etc., shall constitute sufficient basis for rejection. The HDPE pipe shall be homogenous throughout and shall be free of visible cracks, holes, foreign inclusions or other defects. Pipe with gashes, nicks, abrasions or any such physical damage which may have occurred during storage and/or handling which are wider or deeper than 10% of the wall thickness, shall not be used and must be removed from the job site.
- E. All polyethylene pipe shall be manufactured in accordance with ASTM F 714. Dimensions and tolerances for pipe outside diameter and minimum wall thickness shall be in accordance with ASTM F 714.
- F. Tests for compliance with this specification shall be in accordance with the applicable ASTM specifications.

#### **DELIVERY, STORAGE AND HANDLING**

- A. Care shall be taken in shipping, handling, and storage to avoid damaging the HDPE pipe. Extra care shall be taken during cold weather construction. Any pipe damaged in shipment shall be replaced as directed by PWC.
- B. Any pipe or fitting showing a crack, or which has received a blow that may have caused damage, even though the damage may not be visible, shall be identified as rejected and immediately removed from the job site.
- C. Ropes, fabric or rubber protected slings and straps shall be used when handling HDPE pipe and fittings. Chains, cables, or hooks inserted into the pipe ends shall not be used. Two slings spread apart shall be used for lifting each length of pipe. Pipe or fittings shall not be dropped onto rocky or unprepared ground.
- D. While stored, the HDPE pipe shall be adequately supported from below at not more than three (3) foot intervals to prevent deformation. Pipes shall be stored on level ground, preferably turf or sand, free of sharp objects which could damage the pipe. Stacking of the HDPE pipe shall be limited to a height that will not cause excessive deformation of the bottom layers of pipes under the anticipated temperature conditions. Where necessary, due to ground conditions, the HDPE pipe shall be stored on wooden sleepers, spaced suitably and of such width as not to allow deformation of the pipe at the point of contact with the sleeper or between supports. Pipe and fittings shall be stored in a manner which will keep them at ambient outdoor temperatures. Temporary shading as required to meet this requirement shall be provided. Simple covering of the pipe and fittings which allows temperature buildup when exposed to direct sunlight will not be permitted.
- E. The handling of the joined pipe shall be in such a manner that the pipe is not damaged by dragging it over sharp and cutting objects. Slings for handling the pipeline shall not be positioned at butt fused joints. Sections of the HDPE pipes with deep cuts and/or

- gouges shall be removed and the ends of the pipe rejoined.
- F. Any HDPE pipe that has been damaged or does not meet PWC's approval shall be replaced at the Contractor's expense.

## **MATERIALS**

- A. Polyethylene (PE) pipe resins shall be high performance, high molecular weight, high density polyethylene conforming to ASTM D 1248 for Type III or Type IV high density polyethylene and ASTM D 3350 Cell Classification PE 345434C, and shall have a PPI recommended designation of PE 3408. The pipe shall be compounded with a minimum of two (2) percent carbon black to withstand outdoor exposure without loss of properties. Pipe supplied under this specification shall be have a maximum standard dimension ratio (SDR) in accordance with the following:
- |   |          |
|---|----------|
| a. Pipe Bursting                        | SDR 17   |
| b. Directional Drill – Gravity Sewer    | SDR 11   |
| c. Directional Drill – Water/Force Main | SDR 9    |
| d. Sewer Sliplining                     | SDR 32.5 |
- B. The polyethylene compound shall be suitably protected against degradation by ultraviolet light as required by ASTM D 1603.
- C. All piping shall be manufactured from virgin material. If rework compounds are required, only those generated in the manufacturer's own plant from resin compounds of the same class and type from the same raw material supplier shall be used.
- D. Compliance with the above requirements must be certified by the pipe supplier.

## **INSTALLATION**

The Contractor shall take all necessary measures to ensure the HDPE pipe is not damaged or scarred in any way during delivery, storage, or installation. Any gouges in the HDPE pipe will result in the pipe, or section of the pipe, being rejected and replaced with undamaged HDPE pipe at no additional cost to PWC.

Pipe Joining: Sections of the HDPE pipe shall be joined into continuous lengths on the job site above ground, prior to installation. Pipes shall be jointed to one another and to polyethylene fittings by thermal butt-fusion in accordance with ASTM D 2657 and the manufacturer's recommendations. Joints between pipe sections shall be smooth on the inside, i.e., the internal bead must be removed. The tensile strength at yield of the butt-fusion joints shall not be less than the HDPE pipe. Butt-fusion equipment used in the joining procedure shall be capable of meeting all conditions recommended by the pipe manufacturer, including, but not limited to temperature requirements, alignment, and fusion pressures. The joint welding shall be performed by the manufacturer's representative or the Contractor shall be certified for the butt-fusion by the manufacturer. Suitable polyethylene adaptors shall be provided as required.

Caution must be taken to prevent stretching of the HDPE pipe beyond the elastic limit of the polyethylene. Once the pullback operation has started, the operations shall continue to completion.

After installation, a minimum of 48 hours shall be allowed prior to cutting flush with the manholes, in order for the HDPE pipe to experience stress relief. When connecting to adjacent pulled or non-pulled sections of HDPE pipe, allow pulled sections of pipe to extend past the termination point. Ensure that sufficient pipe remains inside the borehole when pullback is completed for connection to the direct bury portion of the project. After the stress relief, the HDPE pipe should be cut in

order to install the necessary valves, tees, fittings as indicated on the Contract Drawings. All connections between the HDPE and the direct bury pipe shall be restrained.

### **TESTING**

Testing of the installed HDPE pipe will be done in accordance with the requirements outlined in Section 02302 – Horizontal Directional Drilling and Section 02660 – Water Distribution, as applicable. No payment will be made until the installed pipe has passed the required tests.

**DIVISION 2  
SITE WORK  
02831 - CHAIN LINK FENCING**

**GENERAL**

Where shown on the plans there shall be installed a "chain link" fence with all necessary posts, braces, top rail, gates, fabric, extension arms, and three strand barbed wire.

The erected fence shall meet the following requirements:

The enclosing fence shall have an overall fabric height of six feet (6') and an additional one foot (1') of three strand barbed wire, for a total height of seven (7'). The gates shall be seven feet (7') in overall height.

**MATERIALS**

Fabric: Fencing shall be chain link #9 gauge aluminized continuously woven wire 2" uniform square mesh without knots or ties, except for knuckling and barbing. Both the top and bottom edges of the fabric shall be barbed unless otherwise shown on the plans. The Contractor shall not piece together a number of short pieces of fence fabric.

Tensile Strength Test: Wire pickets of which this fabric is made to stand a tensile strength test of approximately 70,000 pounds per square inch based on the cross-sectional area of the galvanized wire.

Framework: All posts and other appurtenances used in construction shall be hot-dipped, galvanized with a minimum of 1.8 oz. per square foot surface.

Line Posts: Hot dip galvanized "H" column (2" x 2 1/4") weight 4.1 pounds per linear foot, minimum carbon content 0.355. No used or open seam material will be permitted in posts or rails. (Alternate 2 1/2" O.D. galvanized pipe weight 3.65 pounds per linear foot or C-section line posts of the same dimension as H-post, 0.120 in wall thickness and fabricated from steel conforming to ASTM A-570, Grade E.) Intermediate posts shall be evenly spaced no more than 10 feet apart on center.

Top Rail: Hot dip galvanized pipe 1 5/8" O.D., weight 2.27 pounds per linear foot protected with outside sleeve type couplings at least 7 inches long. No used or open seam material will be permitted.

Terminal Posts: End, corner and pull posts hot dip galvanized pipe 3" O.D. - 5.79 pounds per linear foot. Gate posts hot dip galvanized pipe of "H" construction as specified.

Tension Wire: A bottom tension wire 7 gauge, alzd. (0.4 oz./s.f.), 6 inches above grade. Wire shall be fastened to fabric with aluminum rings at 24" on center and to each intermediate post.

Extension Arms: Hot dip galvanized. Line post arms of pressed steel malleable base; end, and corner post arms of malleable iron; gate posts to have ornamental top. Each extension arm to carry three strands of barbed wire approximately 12 inches out from fence line. Barbed wires to be securely fastened in by means of self-locking grooves. The barbed wire shall support a minimum of 400 lbs. vertical dead load from tip of arm. The barbed wire shall be 4-point pattern composed of two strands of No. 12 1/2-gauge galvanized wire.

Gates: Frame to be galvanized pipe 2.0 inches O.D. weighing 2.27 pounds per foot. Each frame to be equipped with 3/8-inch diameter adjustable truss rods. Gateposts and corner posts shall be 3 inches O.D. weighing 5.11 pounds per foot. Gates are to be manufactured using 2" aluminum tubing in lieu of the specified Schedule 40 steel pipe. Gateposts and corner posts shall be 6 5/8" O.D. for swing gates (greater than 20 feet in length and 4" O.D. for slide gates, weighing minimum of 5.11 pounds per foot. Corner fittings to be heavy pressed steel or malleable castings. Fabric to be same as in fence. Gates to be completed with malleable ball and socket hinges, catch, stops and rest. Hinges to permit gate to swing back against fence, 180 degrees if required. Latches shall be arranged for padlocking so that the padlock will be accessible from both sides of the gate regardless of the latching arrangement.

Braces: Brace material to be hot dip galvanized and same as top rail, to be spaced midway between top rail and ground, and to extend from terminal post to first adjacent line post. Braces to be securely fastened to post by suitable connections, and then trussed from line post back to terminal post with 3/8-inch round rod equipped with a turnbuckle for adjusting.

Fittings: Hot dip galvanized. All fittings to be malleable, cast iron or pressed steel.

Fabric-Bands: Fabric to be fastened to line post with (9 gauge) fabric bands spaced approximately 18 inches apart, and to top rail with wires (9 gauge) spaces approximately 24 inches apart.

Locks: Locks will be provided by the Owner.

## **INSTALLATION**

General: Installation shall be made in a workmanlike manner by skilled workers experienced in the erection of this type of fence and in accordance with the manufacturer's recommendations. The fence shall be erected on a previously prepared surface to the lines and grades indicated on the plans.

Post Setting: All posts shall be set plumb and in alignment into a 36-inch concrete footing of proper size and shape so as to furnish sufficient support to withstand any strain or shock ordinarily brought to bear on a fence of this character. The concrete strength shall be 3000 psi (ASTM C-94) and the foundations a minimum of 9 inches in diameter for line post and 12 inches for terminal post.

Concrete shall be thoroughly compacted so as to be free of voids and finished in a dome. Straight runs shall not exceed 500 feet between brace posts. Concrete shall cure a minimum of 72 hours before any further work is done on the posts.

Fabric: The fabric and barbed wire shall be stretched to the proper tension as recommended by the manufacturer and securely fastened to the framework members to result in a straight fence line without sagging. The bottom of the fabric shall be held as uniformly as is practicable to the finished grade.

**DIVISION 2  
SITE WORK  
02931 - SOD**

**GENERAL**

Restoration of existing lawn areas outside of the public right-of-way disturbed by construction activities shall be by installation of new sod. Restoration and sod shall be performed as soon as practical, but the time period between initial disturbance, the utility installation and sod placement shall not exceed 60 days. Sod is defined as blocks, squares, strips of turf grass and adhering soil used for vegetative planting. Sodding and preparation of the sod bed shall be performed by an experienced landscape subcontractor specializing in this type of operation unless otherwise approved by the Public Works Commission in writing.

The Contractor shall adhere to the standards set forth by the American Association of Nurseryman and the Associated Landscape Contractors of America. All personnel shall be appropriately trained with regard to the degree of involvement so to assure the Owner the highest level of workmanship. Sod species suitable in this area are hybrid bermuda, centipede and zoysia; however the sod placed for each individual's lawn shall be the same species of sod as existing. Sodding may be performed at any time of the year except frozen sod shall not be placed nor shall sod be placed on frozen ground. The Contractor shall adapt his operations to variations in weather or soil conditions as necessary for the successful establishment and growth of a vigorous, disease free and weed free sod lawn.

**MATERIAL**

Materials, equipment and products incorporated in the work shall be approved by the Public Works Commission. The Contractor shall submit a list of the proposed materials with samples, if required. Package materials should be delivered in unopened original containers showing weight, analysis and name of manufacturer. The Contractor shall protect the material from deterioration and/or damage

Sod shall contain 95 percent permanent grass; not more than five (5) percent weeds and undesirable grasses, good texture and free from obnoxious grasses, roots, stones and foreign materials. Sod shall be uniformly 1 ½ to 2 inches thick with a well developed fibrous root mat system in topsoil with clean cut edges. The sod shall be sufficiently dense and cut to the minimum required thickness such that if the sod is suspended by one corner, the sod will not tear apart. The sod shall be recently mowed to a height of not more than three (3) inches prior to harvest. The sod shall be supplied and maintained in a healthy condition as evidence by the grass being a normal green color in appearance, dense, and free from insects, pests, disease or injury. Sod shall be delivered to the job site within 24 hours after being cut and shall be installed within 24 hours after delivery. Any sod which is torn, broken or too dry will be rejected.

**SOIL BED PREPARATION**

Before landscape construction is to begin, the site shall be cleaned and disposed of brush, rubbish, stones, gravel and other foreign material within the area to be landscaped. Exposed ground surfaces disturbed during construction activities shall be graded to the original contours (allowing for the thickness of the sod) or as in the case of an altered contour such as a fill slope, graded as directed by the Public Works Commission to finish grade, or typical cross section. The sod bed shall be excavated to such a depth that after sod placement the top of the sod shall

be flush with surrounding grade or contours. Rake areas to be sodded smooth, free from unsightly variations, bumps, ridges or depressions. Do not start work until conditions are satisfactory and do not work during inclement or impending inclement weather.

The surface area to receive sod shall contain a minimum of four (4) inches of good, fertile, friable, organic natural topsoil loam as a base for laying the sod. Topsoil shall be free of clumps, brush, sticks, weeds, stones, roots, trash or other objectionable material. Contractor shall insure all topsoil to be free of plants or plant parts of quackgrass, johnson grass, nut sedge, poison ivy or other noxious weeds. The Contractor shall furnish and supplement the existing topsoil at no additional costs to the Public Works Commission providing a minimum four (4) inch thickness as specified. Soil preparation shall not be performed in frozen or extremely wet conditions. The finished topsoil bed shall be uniform in grade, with a yard like appearance. All changes in grade shall have a smooth, rounded peaks and valleys.

The soil shall be scarified or otherwise loosened to a depth of not less than five (5) inches and all clods shall be broken. The top four (4) inches shall be worked into an acceptable smooth, friable and uniformly fine texture sod bed by use of soil pulverizes, drags, harrows or by other methods approved by the Public Works Commission. Commercial grade fertilizer (8% nitrogen, 8% phosphate, 8% potash) shall be applied at a rate of 20 pounds per 100 square feet, super-phosphate at 12 pounds per 1,000 square feet and lime (dolomite limestone containing not less than 85% total carbamates) shall be applied at a rate of 25 pounds per 1,000 square feet or at a rate recommended for the type of sod being placed. Apply soil amendments within 24 hours after raking topsoil base surface and not more than 48 hours prior to laying sod. Mix thoroughly a minimum depth into the upper four (4) inches of topsoil and lightly water to aid in dissipation. Sod placement shall not begin until the soil preparation is inspected and approved by the Public Works Commission. During application of soil amendment fertilizer etc., adequate precautions shall be taken to prevent damage to existing features such as traffic, structures, landscape, trees, vegetation, utilities or any other appurtenances. The Contractor shall be required to repair or clean any damages.

### **PLACING SOD**

The Contractor and his landscape subcontractor shall coordinate the placing of the sod to begin within 24 hours after the topsoil base preparation is completed and accepted by the Public Works Commission. Sod shall be brought to the site as near to the time of placing as possible. Store sod in the shade, and keep watered particularly in extreme hot and dry condition to insure vitality and to prevent the dropping off of soil during handling. During wet weather, the sod shall be allowed to dry sufficiently to prevent tearing. Handling shall be done in a manner which will prevent tearing, breaking, drying or other damage. Carefully place sod in rows with the longer side perpendicular to slopes and the ends staggered in each successive row in a brick-like pattern. Butt the ends and sides together tightly and do not overlap or stretch the sod. Do not leave any voids or gaps. Unavoidable gaps shall be closed with small pieces of torn or broken sod if kept moist and approved by the Public Works Commission. After the sod is laid, irrigate thoroughly to allow water to penetrate a minimum six (6) inches into the soil below the sod. Sod shall not be placed when the atmospheric temperature is below 32oF.

Tamp and roll completed sod installation with a manual roller or approved equipment to eliminate minor irregularities and to form close contact with the soil bed immediately after placing and watering. The type of rolling and tamping equipment to be used shall be submitted to the Public Works Commission for approval prior to construction. On steep slopes 3:1 (horizontal and vertical) or greater, in drainage ditches or any areas where sod slipping may occur, anchor sod



with approved wooden stakes (½"x ¾" x 12") or staples spaced not over two (2) feet apart in any direction and/or in sufficient number to prevent slippage or displacement. The anchors shall be driven flush with the surface of the sod. The wide flat side of the stake shall be driven parallel to the slope. Staking shall be done concurrently with sod placement and prior to tamping. Sod shall be laid with the long horizontal edge of the strips parallel to the contour starting at the bottom of the slope. The edge of the sod shall be turned slightly in the ground at the top of a slope and a layer of earth placed over it and compacted so as to conduct the surface water over and onto the top of the sod. Upon completion of the above described work, the surface of the sodded areas shall coincide with the finished grade and not exceed ¼" plus or minus variation to adjoining grade or proposed contour. Extreme care shall be taken to prevent the installed sod from being torn or displaced.

## **MAINTENANCE**

The Contractor shall, at no additional cost to the Public Works Commission, make whatever arrangements necessary to supply water of suitable quality and purity to sustain and encourage vigorous plant growth, and supply all equipment for proper delivery and application to planted areas. Water obtained from a PWC fire hydrant shall be metered and properly protected with an approved backflow prevention device. PWC must inspect and approved any connections to their water system to include the proposed water application and storage equipment. The Contractor shall not use private resident's water. The Contractor is solely responsible to provide watering of the sod. The method of application of water shall be approved by the Public Works Commission. Limit watering to early morning or late afternoon to enable to soil the absorb maximum amount of water.

Maintenance shall begin immediately after sodding operation. The Contractor shall maintain all sodded areas until sod is firmly established and as outlined below. Maintenance will include watering, fertilizer, pest control, soil amendments, disease control, erosion repair, mowing, protecting turf area from traffic (i.e. temporary fences, barriers, signs, etc.) and replacement of any dead or damaged sod.

### Watering

- Water lawn areas once a day with a minimum ½ inch water for the first three (3) weeks after area sodded.
- After the three (3) week period, water twice a week with a ¾ inch of water each time unless a comparable amount of rainfall has occurred.
- Make weekly inspections to determine moisture content of soil and supplement the above watering schedule as needed.
- Excessive runoff puddling and wilting shall be prevented.

### Fertilizer and Pest Control

- Evenly spread fertilizer composite at a rate of 40 pounds per 5,000 square feet or as recommended by the manufacturer. Fertilizer shall not be applied until two (2) weeks after initial placement of the sod or prior to the advent of winter dormancy.
- Treat areas of weed and insect infestation as recommended by the treatment manufacturer.

### Mowing

- The Contractor shall do mowing operations, (in yards not being mowed by residents) until provisional acceptance.
- Mowing shall be done only when the grass is dry with a rotary type mower having a blade height set not lower than one and one half (1½) inches nor higher than three (3) inches.
- Mowing operations shall be conducted at intervals, which ensure grass height does not exceed four (4) inches between mowing.
- The Contractor shall complete at least one mowing operation before the work will be considered for acceptance.

The Contractor shall protect and not allow access of vehicular traffic into any newly sodded areas and shall repair any damaged turf to original grade. Maintenance shall continue for a period of 90 days after placement or until provisional acceptance by the Public Works Commission. A written record shall be furnished to the Owner of the maintenance work performed. At least two weeks shall elapse after chemical control is applied before a request of inspection.

### **ACCEPTANCE**

Fifteen (15) days prior to the end of the 90 day maintenance period, the Contractor shall make a written request to the Public Works Commission for an inspection and provisional acceptance of the sod. Failure to notify the Public Works Commission will not relieve the Contractor of the maintenance provisions required and the Contractor will continue to be responsible for the maintenance of the sod.

Replacement of dead sod shall be performed within seven (7) days after notification by the Public Works Commission and the maintenance period for these areas or individual lawns shall be extended for the 90 day maintenance period. Failure to replace dead sod within the specified seven (7) day period will result in the Public Works Commission having the work performed and deducting the cost from the Contract; however, the Contractor shall be responsible for the maintenance.

Final acceptance will be given upon satisfactory contract performance exhibited at final inspection and acceptance. Sodded areas are to be fully rooted prior to acceptance. The Owner shall be the sole judge as to whether or not the lawns are acceptable. Should any deficiencies be disclosed at final inspection, the Contractor shall make the necessary corrections in a timely manner and request re-inspection.

### **GUARANTEE**

The Contractor shall guarantee a dense, vigorous stand of turf free of weeds, disease, pests or any dead areas more than one half of a square foot in size for a period of 90 days from initial placement or replacement whichever is greater. Total dead area shall not exceed one percent (1%) of total square footage for each individual resident's lawn.

**DIVISION 2  
SITE WORK  
02933 - LAWNS AND GRASSES (SEEDING)**

**GENERAL**

All exposed ground surfaces that have been disturbed during construction shall be graded to original contours as practicable, shaped to drain, and free of trash and debris. Grassing shall be accomplished as soon as practicable after sections of work are completed. Seeding and/or planting shall be performed by an experienced subcontractor specializing in this type of operation, unless otherwise approved by the Public Works Commission in writing. Disturbed sections shall not exceed one mile, without prior approval by the Public Works Commission. Grassing shall be in accordance with the Contract Documents.

**PREPARATION OF THE SOIL**

The surface area to receive seed shall contain a minimum of four (4) inches of good, fertile, friable, organic natural topsoil loam as a base for spreading the seed. Topsoil shall be free of clumps, brush, sticks, weeds, stones, roots, trash or other objectionable material. Contractor shall insure all topsoil to be free of plants or plant parts of quackgrass, johnson grass, nut sedge, poison ivy or other noxious weeds. The Contractor shall furnish and supplement the existing topsoil at no additional costs to the Public Works Commission providing a minimum 4-inch thickness as specified. Soil preparation shall not be performed in frozen or extremely wet conditions. The finished topsoil bed shall be uniform in grade, with a yard like appearance. All changes in grade shall have a smooth, rounded peaks and valleys.

The topsoil shall be loosened and mixed to the depth of four inches (4"). Suitable equipment (cultipackers, harrows, drags) meeting the approval of the Public Works Commission shall be used. This operation shall be accomplished by cutting on one (1) foot centers parallel to the contour of the slopes. On slopes that are steeper than 2:1, both depth preparation and degree of smoothness may be reduced, if approved by the Public Works Commission, but in all cases the slope surface shall be scarified groove, trenched or punctured so as to provide a textural plane of cut forming pockets, ridges, or trenches in which seeding material can lodge. Soil preparation shall not be performed when the soil is frozen, extremely wet or in an otherwise unfavorable working condition. The soil shall be free of any substance that might inhibit plant growth. Assistance of the local agricultural agent is recommended.

Lime shall be applied at the rate of 1/2 tons per acre. 10-20-20 commercial fertilizer shall be applied at the rate of 1,000 pounds per acre and well worked in to the top four inches (4") of top soil. If hydroseeding, use 500 pounds of 10-10-10 fertilizer on slopes steeper than 1/2 horizontal to 1 vertical.

**SEED MIXTURE AND SOWING THE SEED**

Seed shall be seed certified to be the latest season's crop and shall be delivered in original sealed packages bearing the producer's guaranteed analysis for percentages of mixtures and pure live seed. The producer's seed label shall indicate it the minimum percent of pure live seed (which shall be 82.45 for Bermuda, 88 for Rye Grain), the minimum percent of germination in hard seed and maximum percent of weed seed (no more than 1 percent for Bermuda, 0.5 percent for Rye Grain). Seed shall be labeled in conformance with U.S. Department of Agriculture rules and regulations under the Federal Seed Act and applicable State seed laws.

Seed that has become wet, moldy, or otherwise damaged will not be acceptable.

The following seed mixture shall be used:

	<u>POUNDS OF SEED PER ACRE</u>				
	K-31 Fescue	Rye	Grain Centipede	Common	
Bermuda					
April 15 - Sept. 1	75	-	60 (hulled)		5
Aug. 15 - Nov. 15	120	-	25 (hulled)		5
Nov. 1 - April 1	120	120	25 (un-hulled)		5

Note: If there are differences in the seed mixture between the mixture stated in these specifications and that which is specified as part of an approved Erosion Control Plan, the seed mixture specified in the erosion control plan shall take precedence.

Where construction crosses a pasture that has been grassed, the Contractor shall re-seed the area with the same type of grass as found on the site. All highway rights-of-way, and private yards disturbed shall also be re-seeded or with the same type of grass previously found. The seed mixture specification shall be used as a guide and the Contractor is charged with the responsibility of seeding areas with the proper type of grass that matches the existing.

Seed shall be broadcast uniformly by hand or by approved sowing equipment. One half of the seed shall be sown in one direction and the remaining shall be sown at right angles to the first. Do not seed when the wind velocity exceeds five (5) miles per hour. Rake lightly into top 1/8 inch of the soil prior to compacting, with a roller not exceeding 100 pounds.

All seeded areas will be mulched with two (2) tons per acre of small grain straw or wood cellulose fiber spread uniformly, approximately 1/4 of ground should be visible to avoid smothering seedlings. Asphalt emulsion (ASTM D-977 and ASTM D-2028) shall be used to anchor the straw applied at 150 gallons per ton of straw, or crimped to stabilize. Asphalt emulsion shall be required from November 1st to March 31st. The Contractor shall take sufficient precautions to prevent mulch from entering drainage structures through displacement by wind, water or other causes and promptly remove any blockage which may occur.

**SPECIAL CONSIDERATIONS**

Shrubbery shall be expertly removed and carefully preserved for replanting, unless otherwise directed by the Public Works Commission adequate earth ball shall be removed to guard against damage to the root system. Shrubbery shall be replanted only after all construction is complete. The excavation made for replanting shall be six inches (6") larger in every dimension than the root ball removed. This additional space shall be filled with a mixture of one half topsoil and one half peat moss. Care shall be taken to set the top of the ball slightly above or flush with the surrounding surface. Any shrubbery damaged or that dies shall be replaced with an equal or better plant material at the Contractor's expense.

## **MAINTENANCE**

The Contractor shall protect and maintain grassed areas as necessary to establish a uniform turf composed of the grasses specified. The Contractor shall re-seed any bare areas and repair all eroded areas.

Watering of seeded areas will be required during periods of dry weather to promote maximum growth. The Contractor shall supplement natural rainfall to insure a minimum of one (1) inch of rainfall weekly.

Maintenance of lawns begins immediately after the area is planted and continues for the period required to establish acceptable lawns, but not less than sixty (60) days after initial seeding, or until provisional acceptance by Owner. Maintain seeded areas by watering, fertilizing, mowing, weeding and other operations such as rolling, re-grading, replanting, aerating, and mulching as required to establish an acceptable lawn free of eroded or bare areas.

## **ACCEPTANCE**

Fifteen (15) days prior to the end of the sixty (60) day maintenance period, the Contractor shall make a written request to the Owner for an inspection and provisional acceptance of the seeded area. Failure to notify the Owner will not relieve the Contractor of the maintenance provisions required and the Contractor will continue to be responsible for the maintenance of the seeded area.

Replacement of dead seed area(s) shall be performed within seven (7) days after notification by the Public Works Commission and the maintenance period for these areas or individual lawns shall be extended for an additional sixty (60) day maintenance period. Failure to replace seeded area(s) within the specified seven (7) day period will result in the Owner having the work performed and deducting the cost from the Contract; however, the Contractor shall be responsible for the maintenance.

Final acceptance will be given upon satisfactory contract performance exhibited at final inspection and acceptance. Seeded areas are to be fully rooted prior to acceptance. The Owner shall be the sole judge as to whether or not the lawns are acceptable. Should any deficiencies be disclosed at final inspection, the Contractor shall make the necessary corrections in a timely manner and request re-inspection.

Payment to the Contractor for seeding areas will be approved once the seed has been established and meets the requirements of this paragraph of this specification.

## **GUARANTEE**

The Contractor shall guarantee a stand of turf is considered acceptable when a live vigorous stand of permanent grass is established with growing sprouts visible at the surface showing not less than 9 seedlings of permanent grass at least 2 inches long in each square foot, and where no gaps larger than 4 inches in diameter occur anywhere in the lawn area. Permanent grass is defined as Common Bermuda, Centipede, and Fescue.

**DIVISION 2  
SITE WORK  
02934 - SEEDING WETLANDS**

**GENERAL**

All exposed ground surfaces that have been disturbed during construction shall be graded to original contours, reasonably smooth, and free of trash and debris. Grassing shall be accomplished as soon as practicable after sections of work are completed. Seeding shall be performed by an experienced subcontractor specializing in this type of operation, unless otherwise approved by the Engineer in writing. Disturbed sections shall not exceed one half mile, without prior approval by the Engineer. Grassing shall be in accordance with the following specifications:

**PREPARATION OF THE SOIL**

The topsoil shall be loosened and mixed to the depth of 4" to 8". Suitable equipment meeting the approval of the Engineer shall be used. The soil shall be free of clay lumps, brush, weeds, stones, roots, stumps or any other substance that might inhibit plant growth. Assistance of the local agricultural agent is recommended.

Provide agricultural lime at rate required to bring soil acidity to slightly acid - ph 6, according to soil test report.

Lime and fertilizer shall be applied uniformly and mixed with the soil during seedbed preparation. Apply 10-20-10 commercial fertilizers at the rate of 20-lbs./1000 s.f. for warm season mix and 10-20-10 commercial fertilizer at a rate of 20 lbs./1000 s.f. for cool season mix.

Apply 10-10-10 commercial fertilizers at the rate of 20-lbs./1000 s.f. for temporary cover crops. In addition, provide 15-lbs./1000 s.f. of superphosphate.

The following is for the warm season mix:

- a. All warm grass seed shall be debarbed or conditioned by brushing to create a product nearly the same as debarbing. This does not apply to Switchgrass.
- b. Disk two times to break-up crop residue and dirt clods prior to seeding.
- c. Pack soil to create a firm seedbed with a cultipacker or roller.
- d. If a rain shower should fall after the seedbed is prepared but before planting break-up any crust formation.
- e. Seeding shall be installed to a depth of 1/4" utilizing a rangeland drill or conventional grass drills. It is extremely important that seed not be planted deeper than 1/2" depth. Do not disc or harrow after seeding. This will put the seed too deep. A Brillion seeder will be acceptable.

The following seed mixture shall be used:

Dates	Types	Rate
April 1 - July 15	<b><i>Warm Season Mix</i></b> Switchgrass, Cave-in-rock, Alamo  Smartweed; and  Japanese Millet or Sorghum Sudan Grass Hybrids (Mow prior to maturity)	8 pls #/acre or 4 oz./1000 s.f.  2 bulk #/acre or 1 oz./1000 s.f.  20-lb/acre or ½ lbs/1000 s.f.
July 16 - Sept 1	Temporary crop of Japanese Millet or Sorghum Sudan Grass Hybrids (To be followed by permanent mixture)	20-lb/acre or ½ lbs/1000 s.f.
Sept 2 - Nov 1	<b><i>Cool Season Mix</i></b> Reed Canary Grass	12 bulk #/acre or 6 oz./1000 s.f.
	Smartweed	2 bulk #/acre or 1 oz./1000 s.f.
Nov 2 - March 31	Temporary Crop of Wheat (To be followed by permanent mixture)	40 lbs/acre

All highway rights-of-way, and private yards disturbed shall also be re-seeded or sodded with the same type of grass previously found. The seed mixture specification shall be used as a guide and the Contractor is charged with the responsibility of seeding areas with the proper type of grass existing.

Seed shall be broadcast uniformly by hand or by approved sowing equipment. One half of the seed shall be sown in one direction and the remaining shall be sown at right angles to the first. Do not seed when the wind velocity exceeds 5 miles per hour. Rake lightly into top 1/8 inch of the soil prior to compacting, with a roller not exceeding 100 pounds.

All seeded areas will be mulched with 75 pounds to 100-lbs./1000 s.f. of clean wheat straw, spread uniformly, approximately 1/4 of ground should be visible to avoid smothering seedlings. If hydro-seeded, use virgin paper mulch only. The Contractor shall take sufficient precautions to prevent mulch from entering drainage structures through displacement by wind; water or other causes and promptly remove any blockage, which may occur.

**MAINTENANCE AND GUARANTEE**

The Contractor shall protect and maintain grassed areas as necessary to establish a uniform turf composed of the grasses specified. The Contractor shall re-seed any bare areas and repair all eroded areas.

Maintain seeded areas by watering, fertilizing, mowing, weeding, and other operations such as rolling, regrading, replanting, aerating, mulching as required to establish an acceptable lawn free of eroded or bare areas.

### **ACCEPTANCE**

The Contractor shall guarantee a stand of turf is considered acceptable when a live vigorous stand of permanent grass is established with growing sprouts visible at the surface showing not less than 9 seedlings of permanent grass at least 2 inches long in each square foot, and where no gaps larger than 4 inches in diameter occur anywhere in the seeded area.



**DIVISION 2  
SITE WORK  
03301 - CONCRETE CONSTRUCTION (UTILITY)**

**GENERAL**

Concrete construction specified in this section shall be applicable to all "site work" and is not intended to cover general building specifications. The concrete work shall include all furnishing, hauling, fine grading and subgrade, form work, etc. and all incidentals necessary for completion of the work as it pertains.

**MATERIALS**

Concrete

The Contractor shall furnish and place concrete in strict accordance with the requirements of ACI 318 (most recent edition). Ready-mixed concrete from an approved mixing plan shall be used throughout the work and conform to the requirements of ASTM C-94 for batch, mixing, and transporting. Concrete shall be in accordance with the following requirements:

- |   |                        |
|---|------------------------|
| A. Under Ground - Regular Weight Concrete                             |                        |
| 28-day compressive strength   | 3000 psi               |
| Coarse aggregate  | 1 ½" max. size stone   |
| Slump   | 2" minimum, 4" maximum |
| Air Entrainment   | No requirement         |
| B. Walls, Slabs, Sidewalks, Curb and Gutter - Regular Weight Concrete |                        |
| 28-day compressive strength   | 3000 psi               |
| Coarse aggregate  | ¾" max. size stone     |
| Slump   | 2" minimum, 4" maximum |
| Air Entrainment   | 5 more or less 1       |

The Contractor shall submit for approval mix designs, designed and tested by an approved testing laboratory, following the requirements of ACI 318 for each class of concrete to be used on this project. Mix designs in excess of one year old shall be verified. The Contractor will be responsible for all costs involved in the mix design. Material suppliers and material proportions incorporated in the mix design and certification shall not change without written permission from the Public Works Commission.

Admixtures used to produce entrained or air shall be sulfated hydrocarbons or neutralized vinsol resins conforming to ASTM C-260. Calcium chloride, other accelerators, or "anti-freeze" shall not be used without written approval by the Public Works Commission.

Reinforcing Steel

Reinforcing bars shall be new billet stock and shall conform to ASTM A-615, Grade 60. Bars shall be deformed to conform to ASTM A-305. The Contractor shall check and submit for approval four (4) sets of shop and erection drawings prepared by the fabricator. Reinforcement detailing and

placement shall conform to ACI 318. All reinforcing bars shall be tied in place according to approved erection drawings, using bar supports and accessories conforming to ACI 315. Laps or splices shall conform to ACI 318, and consist of the following minimum dimensions:

Tension Splices	36 Bar Diameters
Compression Splices	30 Bar Diameters

All reinforcing bars shall be tagged and stored in such manner as to be readily available at the time needed. Tag mark substitutions will not be made.

Welded wire mesh fabric reinforcing shall conform to the requirements of ASTM A-185. Lap splices shall be at least one full mesh plus 2" staggered to avoid continuous laps in either direction and securely wired or clipped.

### **GRADING**

The Contractor shall use every effort to observe any possible misalignments in line or grade of the installed forms and will call such to the attention of the Public Works Commission promptly. The Contractor is cautioned that he shall be responsible for any damage to utility lines caused by his negligence. The Public Works Commission or his representative shall then inspect the forms and if approved, pouring operations may begin. Where unstable material exists, the Contractor shall remove such material to a depth required to provide a stable subgrade at no additional cost to the Public Works Commission.

### **FORM WORK**

Metal forms shall be used throughout the work except for short, odd length sections and in accordance with ACI 301 and ACI 347 (most recent editions). Earth cuts may be used as forms for unexposed vertical surfaces on footings, provided the soil and workmanship allow an accurate and curable excavation. Forms shall be kept in good condition at all times. Any forms which have become out of shape or otherwise unsuitable shall be removed from the work. Forms shall be of such section and design that they will adequately support the concrete and any construction equipment used in the work. Form sections shall be provided with interlocking joints to ensure that the forms are tightly jointed together free from movement. Forms shall be held in place by metal pins, not less than eighteen (18) inches in length, with fastenings of metal and wedges to insure a correct, rigid setting.

Forms shall be of the dimension required for the designed cross-section shown on the plans. Built up sections to attain the required depth will not be permitted. Forms shall be set true to the lines and grades established by the Design Engineer or as indicated on the plans.

Forms shall be held rigidly in position and shall be of sufficient strength to resist springing out of line when concrete is placed.

### **PLACING CONCRETE**

Prior to placing concrete, the subgrade shall be moistened and the contact side of the forms shall be cleaned and coated with a heavy oil. The Contractor shall not place any concrete without the

forms, reinforcing steel and subgrade being inspected and approved by the Design Engineer. Placing of concrete is to be in accordance with ACI 304 (most recent edition). Water shall be removed from the excavation before placing concrete and water shall be diverted to prevent washing over freshly deposited concrete.

Concrete shall be placed as not to disturb concrete already in place and in such a manner as to require the minimum amount of lateral movement. Concrete shall be deposited in the forms without segregation. A tremie shall be used when the fall exceeds five (5) feet. Care shall be taken not to upset any forms during the concrete pouring operations. Any concrete showing misalignment due to form movement shall be removed and replaced at no additional cost to the Public Works Commission.

All concrete shall be consolidated in accordance with ACI 309 (most recent edition). Mechanical vibrators shall be operated by experienced workmen. Spading and rodding may be required to supplement mechanical vibration. Consolidation shall be adequate to remove any voids and after removal of the forms, no honeycomb shall be present. Should any honeycomb be present, the Design Engineer shall determine if the honeycomb is of a minor nature, the voids may be filled with mortar as approved by the Design Engineer.

All concrete within forms shall be brought to true section by the use of an approved straight edge and shall be tamped with straight edge to bring mortar to the surface, after which it shall be floated smooth by means of wood floats. No steel floats will be permitted. After true surface of section has been obtained, and after initial set has taken place, the entire surface shall be brushed with a dampened brush. All joints and all exposed edges shall be rounded off with approved jointing and edging tools. The type of finish required will be specified in the specific item of work specified or indicated on the drawings. All exposed surfaces of retaining walls, structures, etc. shall be given a Class 2 finish with ¼ inch chamfered edges.

No more concrete shall be laid than can be properly finished and covered during the daylight, unless adequate artificial light satisfactory to the Design Engineer is provided.

Immediately after finishing operations have been completed, the entire surface of the concrete shall be sprayed with an approved curing compound. The use of liquid retarding agents shall conform to standards specified by current AASHTO or ASTM Specifications.

Cold weather concreting shall be in accordance with ACI 306 (most recent edition) and hot weather concreting shall be in accordance with ACI 305 (most recent edition). Concreting shall be done when weather conditions are favorable unless otherwise directed by the Design Engineer. Concrete operations shall be discontinued when the temperature of 40 degrees Fahrenheit is reached on a falling thermometer. No concreting shall be attempted when local weather bureaus indicate temperatures below freezing within the ensuing 24 hours unless proper precautions are made to protect concrete by covering with straw or other thermal insulation satisfactory to the Design Engineer. The Contractor shall be responsible for the quality and strength of the concrete laid during cold weather or hot weather and any concrete damaged by frost action or freezing shall be removed and replaced as directed by the Design Engineer and/or the Public Works Commission at the Contractor's expense.

Forms shall not be removed from the concrete for a minimum of 7 days, unless approved by the

Design Engineer. The Contractor shall apply a curing compound or provide measures to maintain moisture for proper curing at his expense, if early form removal is approved. Immediately after the forms have been removed, all honeycomb areas shall be repaired (with one-part cement and two parts sand) and earth backfill material shall be placed adjacent to the finished concrete and smoothed off to prevent an accumulation of standing water, subgrade saturation or under wash in the event of rain.

Both pedestrian and vehicle traffic shall be excluded from crossing the concrete for a period of 14 days by the erection and maintenance of suitable barricades. Contractor shall be responsible for any damage resulting from traffic within the 14-day period and he shall remove and replace any concrete damaged as directed by the Design Engineer and/or Public Works Commission.

### **MASONRY MATERIALS**

Brick shall be in accordance with ASTM C-32 Grade MS laid in full beds of mortar with shove joints.

Concrete masonry blocks shall be in accordance with ASTM C-139. Blocks shall be at least 5", but not more than 8" in thickness nor less than 8" in length and of such shape that the joints can be effectively sealed and bonded with cement mortar.

Cement mortar for brick work shall be in accordance with ASTM C-270, Type M. Use Type IIA cement in accordance with ASTM C-150.

### **TESTING**

The requirements of ACI318 (most recent edition) shall be used to control the evaluation of all concrete strengths. The strength is to be checked during construction by four (4) cylinders at the option and cost of the Public Works Commission, of which 1 shall be broken at 7 days, 2 at 28 days. If the specified strength is not achieved in 28 days, 1 reserved shall be stored and broken as specified by the Design Engineer. Cylinders shall be made and stored in accordance with ASTM C-13. Cylinders shall be for each day concrete is poured in excess of 10 cubic yards of each different type of concrete, as determined by the Design Engineer. All additional expenses required because of the failure of the materials to meet routine testing requirements, or poorly scheduled concrete deliveries, shall be borne by the Contractor.

**DIVISION 2  
SITE WORK  
09801 - ANTI-MICROBIAL ADMIXTURE**

**GENERAL**

All reinforced concrete precast manholes shall include a liquid anti-microbial admixture to render the concrete uninhabitable for bacterial growth. The admixture shall be included in the fabrication of the manhole by an approved concrete precast manhole manufacturer. Coatings applied to the interior walls of the manhole shall not be acceptable.

Further, all field mixed mortar, utilized in concrete precast manholes, shall include the anti-microbial admixture. The intent and purpose of this specification is to render all concrete and/or mortar within sanitary sewer service uninhabitable for bacterial growth. Any defects shall be cause for the replacement and correction of such defect as directed by Fayetteville Public Works Commission (PWC), at no expense to Fayetteville Public Works Commission.

**RELATED SECTIONS**

- A. 02730 – Sanitary Sewer Systems
- B. 02732 – Sewage Force Mains

**REFERENCES**

- A. ASTM C478 – Standard Specification for Precast Reinforced Concrete Manhole Sections
- B. ASTM C1443 – Standard Specification for Precast Reinforced Concrete Pipe
- C. ASTM C1577 – Standard Specification for Precast Reinforced Concrete Pipe

**SUBMITTALS**

All submittals shall be provided in accordance with the Contract Documents, and the requirements outlined herein. The Contractor shall submit, in accordance with the Contract Documents, product data, certifications, and product data, to include the following:

1. U.S. Environmental Protection Agency (EPA) registration number.
2. Documentation that the product has a minimum of 10 years of successful prevention of microbial induced corrosion in sanitary sewers.
3. Documentation that the precast facility is certified by the anti-microbial manufacturer.
4. Documentation from the precast facility stating that the correct amount and correct mixing procedure was followed for all anti-microbial concrete.

**QUALITY ASSURANCE**

A color identifier shall be applied to the interior of each concrete piece fabricated with the anti-microbial admixture. Each piece shall also be plainly stenciled with the name of the anti-microbial admixture on the exterior of each piece.

## **MATERIALS**

All manholes shall conform to PWC standard specifications and details, unless otherwise approved in writing by Fayetteville Public Works Commission. All concrete and mortar utilized in the construction of the manholes shall contain an anti-microbial admixture.

### **Anti-Microbial Admixture:**

The liquid anti-microbial admixture shall be used in accordance with the manufacturer's recommendations. The amount of the admixture shall be included in the total water content of the concrete or mortar mix design. The admixture shall be added to the concrete or mortar mix water, to ensure even distribution of the admixture throughout the concrete or mortar mix. When properly prepared, the anti-microbial admixture shall render the concrete or mortar uninhabitable for bacterial growth.

The anti-microbial admixture shall be ConShield, ConBlock, or approved equal. The ConShield liquid anti-microbial admixture can be obtained from ConShield Technologies, Inc. or an approved precast facility. The ConBlock liquid anti-microbial admixture can be obtained from ConSeal Concrete Sealants, Inc., or an approved precast facility.

### **Field Repairs:**

Field repairs to the precast concrete or mortar shall be in accordance with the admixture manufacturer's recommendations. All field repairs shall be completed in accordance with PWC requirements.

## **ACCEPTANCE**

Acceptance of the concrete and mortar with the anti-microbial admixture shall be based on conformance with the requirements herein, Fayetteville Public Works Commission's review of the installed manhole, and results of all testing.

**DIVISION 2  
SITE WORK  
09802 - SPECIAL COATINGS – CERAMIC EPOXY**

**GENERAL**

The interior surfaces of all ductile iron pipe and fittings shall be full coated with a ceramic epoxy lining. The ceramic epoxy lining shall be applied to ductile iron pipe free of any other interior lining material. The finish coat shall be applied to yield a minimum dry film thickness of 40 mils for a complete lining.

**MATERIALS**

The lining material shall be an amine cured novalac epoxy containing at least 20% by volume of ceramic quarts pigment.

The epoxy material shall meet the following minimum performance requirements:

Permeability Rating: 0.00 perms when tested according to ASTM E-96 Procedure A with a test duration of 30 days.

ASTM 6-95 Cathodic Disbandment: 1.5 volts at 77° F.

ASTM B-117 Salt Spray: 0.00 undercutting after one year.

<u>Immersion Testing ASTM D-714</u>	<u>Duration</u>
20% Sulfuric Acid	1 Year
25% Sodium Hydroxide at 140° F	1 Year
160° F Distilled Water	1 Year
120° F Tap Water	1 Year

The above requirements shall be verified and tested by an approved testing laboratory. Copies of the laboratory test showing that the lining conforms to the specifications shall be furnished to the Public Works Commission, certified by the Supplier.

**APPLICATION OF LININGS**

Surface Preparation: All interior barrel and joint surface areas which will be exposed to the sewer liquids and gases shall be prepared for lining by removing all laitance form oil and other loose, foreign or deleterious materials which would adversely affect the bond of the lining compound of the pipe surface. All areas to receive the protective coating shall be abrasive blasted using compressed air nozzles with sand or grit media. The entire surface to be lined shall be struck with blast media so that all rust, loose oxides, etc., are removed from the surface. Any area where rust appears before lining must be re-blasted.

Qualification of Applicator and Workmen:

The lining shall be applied by a competent firm with a five-year history of lining sewer pipe. The workmen employed by the applicator shall be experienced and competent in the application and inspection of the lining compound to be applied. The Public Works Commission shall have the right to require the applicator to furnish bonds covering proper performance and guaranteeing the payment of all obligations arising as a result of improper materials and workmanship.

Equipment: All application equipment shall be as recommended by the suppliers of the lining compound.

Application Technique: After the surface has been thoroughly prepared for application, the interior of the pipe shall be coated with the ceramic epoxy to a minimum dry film thickness of 40 mils. No lining shall take place when the substrate or ambient temperature is below 40 degrees F. The surface must be dry and dust free. The number of coats of lining material applied shall be as recommended by the lining manufacturer, but in no case shall it be applied above the dry film thickness per coat recommended by the lining manufacturer. The time between coats shall be that specified by the lining manufacturer.

Repair: All damaged areas or test areas shall be repaired in accordance with the manufacturer's recommendation, so that the repaired areas are equal to the undamaged lined areas in all respects.

Inspection: All pipe linings shall be checked for thickness using a magnetic film thickness gauge, the thickness testing shall be done in accordance with the method outlined in SSPC-PA-2 film thickness rating. The interior linings shall also be tested for pinholes with a non-destructive 2,500-volt test. Any defects found shall be repaired as noted above.

Markings: Each joint, manhole unit, or pipe bend special shall be marked with the date of application of the coating system, the date of inspection, and the numerical sequence of application on that date.

Shipping and Handling: Equipment used to handle and transport the lined pipe shall be suitably designed and operated not to damage the lining. Any damage which does occur shall be repaired prior to the installation of the pipe in accordance with the manufacturer's recommendations, so the repaired area is equal to the undamaged lining in all respects.



**DIVISION 2  
SITE WORK**

**09804 - SPECIAL COATINGS –EPOXY LINING DUCTILE IRON PIPE AND FITTINGS**

**GENERAL**

The interior surfaces of all ductile iron pipe and fittings in sanitary sewer service shall be fully coated with a ceramic epoxy lining. The lining system shall be a two component, amine cured novalac epoxy. The ceramic epoxy lining shall be applied to ductile iron pipe free of any other interior lining material. The finish coat shall be applied to yield a minimum dry film thickness of 40 mils for a complete lining. Any defects in the lining shall result in the pipe or fitting being replaced, at no additional cost to the Public Works Commission.

**RELATED SECTIONS**

- A. 02730 – Sanitary Sewer Systems
- B. 02732 – Sewage Force Mains

**REFERENCES**

- A. ASTM B 117 – Standard Practice for Operating Salt Spray (Fog) Apparatus
- B. ASTM C 413 – Standard Test Method for Absorption of Chemical-Resistant Mortars, Grouts, Monolithic Surfacing, and Polymer Concretes
- C. ASTM C 868 – Standard Test Method for Chemical Resistance of Protective Linings
- D. ASTM D 714 – Standard Test Method for Evaluating Degree of Blistering of Paints
- E. ASTM D 870 – Standard Practice for Testing Water Resistance of Coatings Using Water Immersion
- F. ASTM D 1308 – Standard Test Method for Effect of Household Chemicals on Clear and Pigmented Organic Finishes
- G. ASTM D 1653 – Standard Test Methods for Water Vapor Transmission of Organic Coatings
- H. ASTM D 2240 – Standard Test Method for Rubber Property – Durometer Hardness
- I. ASTM D 2370 – Standard Test Method for Tensile Properties of Organic Coatings
- J. ASTM D 2583 – Standard Test Method ofr Indentation Hardness of Rigid Plastics by Means of a Barcol Impressor
- K. ASTM D 2794 – Standard Test Method for Resistance of Organic Coatings to the Effects of Rapid Deformation (Impact)
- L. ASTM D 4060 – Standard Test Method for Abrasion Resistance of Organic Coatings by the Taber Abraser
- M. ASTM D 4400 – Standard Test Method for Sag Resistance of Paints Using a Multinotch Applicator
- N. ASTM D 4541 – Standard Test Method for Pull-Off Strength of Coatings Using Portable Adhesion Testers
- O. ASTM G 8 – Standard Test Methods for Cathodic Disbonding of Pipeline Coatings
- P. ASTM G 95 – Standard Test Method for Cathodic Disbondment Test of Pipeline Coatings
- Q. ASTM G154 – Standard Practice for Operating Fluorescent Ultraviolet Lamp Apparatus for Exposure of Nonmetallic Materials

Unless otherwise specified, references to documents shall mean the documents in effect at the time of bid. If the referenced document(s) have been discontinued by the issuing organization, references to those documents shall mean the replacement documents or the last version of the document before it was discontinued.

Where conflicts exist between the standards and this specification, the more stringent shall apply.

**MATERIALS**

All ductile iron pipe and fittings shall be in accordance with the Public Works Commission standard specification 02730 – Sanitary Sewer Systems, Public Works Commission standard specification 02732 – Sewage Force Mains, and these Contract Documents.

The lining material shall be an amine cured novalac epoxy containing at least 20% by volume of ceramic quartz pigment (no silica fume, fly ash, or alumina dust). The lining shall be both coal tar (polycyclic aromatic hydrocarbons) free and hazardous air polluting solvents (HAPS) free. The lining system shall be 100% solids by volume.

The ceramic epoxy lining system shall be the Perma-Shield PL Series 431 as manufactured by Tnemec Company, Inc., Permox-CTF as manufactured by Permite Corporation, or approved equal.

The ceramic epoxy lining system shall meet the following minimum performance requirements:

- A. Abrasion (ASTM D 4060, CS-17 wheel, 1,000 grams) – 76 mg loss
- B. Adhesion (ASTM D 4541) – not less than 1,860 psi
- C. Severe Wastewater Analysis Test (150oF, 500 ppm H2S, 4,000 ppm NaCl, 10% sulfuric acid, EIS Permeation Analysis) – Initial impedance of 11.2 (log-z). No blistering, cracking, checking, or loss of adhesion. Reduction in electrical impedance of 0.5 after 28 days of exposure.
- D. Cathodic Disbondment (ASTM G 8, 1.5 V, Classification Group A) – no more than 0.000 inch disbonded equivalent circle diameter.
- E. Dielectric Strength (ASTM D 149) – greater than 600 V per mil
- F. Hardness (ASTM D 2240) – Shore D hardness of 79
- G. Impact (ASTM D2794) – No visible cracking or delamination after 160 inch-pounds direct impact.
- H. Chemical resistance by immersion testing, in accordance with ASTM D 714, as outlined in the following table:

20% Sulfuric Acid at 77° F	2 years, no effect
25% Sodium Hydroxide at 140° F	2 years, no effect
5% Sodium Chloride at 77° F	2 years, no effect
Distilled Water at 160° F	2 years, no effect

- I. Salt Spray (ASTM B 117) – No blistering, cracking, rusting, or delamination of film. No rust creepage at scribe after 1,000 hours.
- J. Sag Resistance (ASTM D 4400) – Not less than 90 mills wet film thickness.

- K. Water Absorption (ASTM C 413) – 0.0 percent water absorption
- L. Water Vapor Transmission (ASTM D 1653, Method B, Wet Cup, Condition C) – 1.25 g/m<sup>2</sup> per 24 hour water vapor transmission and 0.09 perms water vapor permeance.

The above requirements shall be verified and tested by an approved testing laboratory. Copies of the laboratory test showing that the lining conforms to the specifications shall be furnished to the Public Works Commission upon written request and certified by the Supplier.

### **QUALITY ASSURANCE**

The manufacturer of the specified coating system shall have a minimum of 10 years' experience in manufacturing high performance epoxy coating systems. The epoxy coating material shall be from a single manufacturer.

Application of the ceramic epoxy lining system shall be in accordance with the manufacturer's requirements. Preparation of the ductile iron pipe to be lined shall be completed by an installer approved by the lining system manufacturer.

### **SUBMITTALS**

In accordance with these Contract Documents, the Contractor shall submit the following:

1. Manufacturer's certification that the coatings comply with the specified requirements and are suitable for the intended application.
2. Product data sheet.
3. Material Safety Data Sheet.
4. Copies of test data for all the physical, chemical, and permeation properties listed within this specification.

### **WARRANTY**

The ceramic epoxy lining manufacturer shall warranty its products as free from material defects for a period of five (5) years. The Public Works Commission will solely determine whether the pipe should be replaced if any defects are discovered in the lining within the warranty period. All costs to replace the pipe or fitting, including but not limited to, bypass pumping, excavation, and traffic control shall be the manufacturer's responsibility.

### **APPLICATION OF LININGS**

Application of the ceramic lining system shall be completed by an installer approved by the manufacturer of the lining system.

Surface Preparation: All interior barrel and joint surface areas which will be exposed to the sewer liquids and gases shall be prepared for lining by removing all laitance, form oil and other loose, foreign or deleterious materials which would adversely affect the bond of the lining compound of the pipe surface. All areas to receive the protective coating shall be abrasive blasted using compressed air nozzles with sand or grit media. The entire surface to be lined shall be struck with blast media so that all rust, loose oxides, etc., are removed from the surface. Any area where rust appears before lining must be re-blasted.

Qualification of Applicator and Workmen: The ceramic epoxy lining shall be applied by a competent firm with a ten (10) year history of lining sewer pipe. The workmen employed by the applicator shall be experienced and competent in the application and inspection of the lining compound to be applied. The Public Works Commission shall have the right to require the applicator to furnish bonds covering proper performance and guaranteeing the payment of all obligations arising as a result of improper materials and workmanship.

Equipment: All application equipment shall be as recommended by the suppliers of the lining compound.

Application Technique: After the surface has been thoroughly prepared for application, the interior of the pipe shall be coated with the ceramic epoxy to a minimum dry film thickness of 40 mils. No lining shall take place when the substrate or ambient temperature is below 40°F. The surface must be dry and dust free. The number of coats of lining material applied shall be as recommended by the lining manufacturer, but in no case shall it be applied above the dry film thickness per coat recommended by the lining manufacturer. The time between coats shall be that specified by the lining manufacturer.

Repair: All damaged areas or test areas shall be repaired by the lining manufacturer prior to shipment, in accordance with the manufacturer's recommendation, so that the repaired areas are equal to the undamaged lined areas in all respects.

Inspection: All pipe linings shall be checked for thickness using a magnetic film thickness gauge. The thickness testing shall be done in accordance with the method outlined in SSPC-PA-2 film thickness rating. The interior linings shall also be tested for pinholes with a non-destructive 2,500 volt test. Any defects found shall be repaired as noted above. All ceramic epoxy lined pipe and fittings shall be visually inspected for any defects, including runs, sags, or debris within the lining. All repairs shall be performed by the manufacturer prior to shipment.

Markings: Each joint, manhole unit, or fitting shall be marked with the date of application of the coating system, the date of inspection, and the numerical sequence of application on that date.

Shipping and Handling: Equipment used to handle and transport the lined pipe shall be suitably designed and operated not to damage the lining. Any damaged pipe or fitting shall be replaced at no cost to the Public Works Commission.

## **INSTALLATION**

Cutting Pipe: The Contractor shall cut the pipe without damaging the pipe or interior ceramic epoxy coating. All cuts shall be at right angles to the pipe axis. All cut ends shall be dressed with a power grinder to remove all sharp edges. The cut ends of push-on joint pipe shall be beveled in accordance with the pipe manufacturer's instructions. All field cuts shall be coated and sealed

prior to installation. Application of the lining shall be done in accordance with the ceramic epoxy lining manufacturer's recommendations.

Handling: All ceramic epoxy lined pipe and fittings shall be handled only from the outside. No forks, chains, straps, hooks, cables, or other equipment shall be placed inside the pipe and fittings for lifting, positioning, or installation. The pipe and fittings shall not be dropped or unloaded by rolling. The pipe and fittings shall not strike sharp objects while moving or unloaded. Ductile iron pipe shall not be placed on grade utilizing hydraulic pressure from machinery or hammers. The use of nylon straps or other similar lifting devices are to be used.

Pipe Installation: All pipe and fittings shall be installed in accordance with PWC standard specifications 02222 – Excavation, Trenching, and Backfilling for Utility Systems, 02730 – Sanitary Sewer Systems, 02732 – Sewage Force Mains, and these Contract Documents.

## **APPENDIX A – LETTER OF APPROVAL**

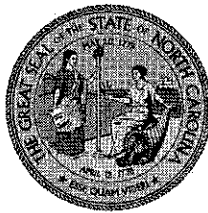

NORTH CAROLINA  
Environmental Quality

ROY COOPER

Governor

ELIZABETH S. BISER

Secretary

BRIAN WRENN

Director

October 20, 2022

## LETTER OF APPROVAL

Fayetteville Public Works Commission  
Misty Manning, Engineering Manager  
Post Office Box 1089  
Fayetteville, NC 28302

RE: Project Name: Fayetteville Annexation PhV Proj. XI Const. Area 25 Lake Rim  
Acres Approved: 17.12  
Project ID: CUMBE-2023-014  
County: Cumberland, City: Fayetteville  
Address: Gooden Drive  
River Basin: Cape Fear  
Stream Classification: Other  
Submitted by: David Vaughn  
Date Received by LQS: September 22, 2022  
Plan Type: Utility

Dear Mrs. Manning:

The subject erosion and sedimentation control plan has been approved by default. The Sedimentation Pollution Control Act (hereinafter "Act") states that this plan must be filed a minimum of 30 days (15 days for revised plans) prior to the activity and the approving authority must approve or disapprove the submitted plan within 30 days (15 days for revised plans) of receipt of G.S. 113A-54.1. The Act further states that if the approving authority fails to approve or disapprove the submitted plan within the 30-day (15 days for revised plans) period, the plan will be deemed approved. The enclosed Certificate of Approval must be posted at the job site. This plan approval shall expire three (3) years following the date of approval, if no land-disturbing activity has been undertaken, as is required by Title 15A NCAC 4B .0129.

As of April 1, 2019, all new construction activities are required to complete and submit an electronic Notice of Intent (NOI) form requesting a Certificate of Coverage (COC) under the NCG010000 Construction Stormwater General Permit. This form **MUST** be submitted and COC issued prior to the commencement of any land disturbing activity on the above-named project. The NOI form may be accessed at [deq.nc.gov/NCG01](http://deq.nc.gov/NCG01). Please direct questions about the NOI form to Annette Lucas at [Annette.lucas@ncdenr.gov](mailto:Annette.lucas@ncdenr.gov) or Paul Clark at [Paul.clark@ncdenr.gov](mailto:Paul.clark@ncdenr.gov). After you submit a complete and correct NOI Form, a COC will be emailed to you within **three business days**. Initially, DEMLR will not charge a fee for coverage under the NCG01 permit. However, on or after June 1,



North Carolina Department of Environmental Quality | Division of Energy, Mineral and Land Resources  
Fayetteville Regional Office | 225 Green Street, Suite 714 | Fayetteville, North Carolina 28301  
910.433.3300

2019, a \$100 fee will be charged annually. This fee is to be sent to the DEMLR Stormwater Central Office staff in Raleigh. Title 15A NCAC 4B .0118(a) and the NCG01 permit require that the following documentation be kept on file at the job site:

1. The approved E&SC plan as well as any approved deviation.
2. The NCG01 permit and the COC, once it is received.
3. Records of inspections made during the previous 30 days.

Also, this letter gives the notice required by G.S. 113A-61.1(a) of our right of periodic inspection to insure compliance with the approved plan.

North Carolina's Sedimentation Pollution Control Act is performance-oriented, requiring protection of existing natural resources and adjoining properties. If, following the commencement of this project, the erosion and sedimentation control plan is inadequate to meet the requirements of the Sedimentation Pollution Control Act of 1973 (North Carolina General Statute 113A-51 through 66), this office may require revisions to the plan and implementation of the revisions to insure compliance with the Act.

Acceptance and approval of this plan is conditioned upon your compliance with Federal and State water quality laws, regulations, and rules. In addition, local city or county ordinances or rules may also apply to this land-disturbing activity. This approval does not supersede any other permit or approval.

Please note that this approval is based in part on the accuracy of the information provided in the Financial Responsibility Form, which you provided. You are requested to file an amended form if there is any change in the information included on the form. This permit allows for a land-disturbance, as called for on the application plan, not to exceed the approved acres. Exceeding the acreage will be a violation of this permit and would require a revised plan and additional application fee. Any addition in impervious surface, over that already noted on the approved plan, would also require a revised plan to verify the appropriateness of the erosion control measures and the stormwater retention measures. (GS 113A-54.1(b)). In addition, it would be helpful if you notify this office of the proposed starting date for this project. Please notify us if you plan to have a preconstruction conference.

Your cooperation is appreciated.

Sincerely,



Chris Baker  
Assistant Regional Engineer  
DEMLR - Fayetteville Regional Office

Enclosures: Certificate of Approval

cc: David Vaughn, P. E., Moorman, Kizer & Reitzel, Inc. – email copy  
Joseph Staton, City of Fayetteville Permit Office – email copy  
Fayetteville Regional Office



## **APPENDIX B – PERMIT**

ROY COOPER  
Governor

MICHAEL S. REGAN  
Secretary

S. DANIEL SMITH  
Director



NORTH CAROLINA  
Environmental Quality

April 17, 2020

DWR # 20-0412  
Cumberland County

Fayetteville Public Works Commission  
Attn: Joe E. Glass  
955 Old Wilmington Road  
Fayetteville, NC 28301

**Subject: APPROVAL OF 401 WATER QUALITY CERTIFICATION WITH ADDITIONAL  
CONDITIONS**

PWC Phase V Area 25 Annex

Dear Mr. Glass:

You have our approval for the impacts listed below for the purpose described in your application dated March 25, 2020, received by the Division of Water Resources (Division) March 25, 2020, additional information provided on April 6, 2020 and payment received on March 26, 2020. These impacts are covered by the attached Water Quality General Certification Number(s) 4133 and the conditions listed below. This certification is associated with the use of Nationwide Permit Number(s) 12 once it is issued to you by the U.S. Army Corps of Engineers. Please note that you should get any other federal, state or local permits before proceeding with your project, including those required by (but not limited to) Sediment and Erosion Control, Non-Discharge, and Water Supply Watershed regulations.

This approval requires you to follow the conditions listed in the enclosed certification(s) or general permit and the following additional conditions:

1. The following impacts are hereby approved provided that all of the other specific and general conditions of the Certification are met. No other impacts are approved, including incidental impacts. [15A NCAC 02H .0506(b)].



North Carolina Department of Environmental Quality | Division of Water Resources  
Fayetteville Regional Office | 225 Green Street, Suite 714 | Fayetteville, North Carolina 28301  
910.433.3300

Type of Impact	Amount Approved (units) Permanent	Amount Approved (units) Temporary
Intermittent Stream	(linear feet)	30 (linear feet)

2. This approval is for the purpose and design described in your application and the additional information provided. The plans and specifications for this project are incorporated by reference as part of the Certification. If you change your project, you must notify the Division and you may be required to submit a new application package with the appropriate fee. If the property is sold, the new owner must be given a copy of this approval letter and General Certification(s)/Permit/Authorization and is responsible for complying with all conditions. [15A NCAC 02H .0507(d)(2)].
3. The permittee shall report to the Fayetteville Regional Office any noncompliance with this certification, any violation of stream or wetland standards [15A NCAC 02B .0200] including but not limited to sediment impacts, and any violation of state regulated riparian buffer rules [15A NCAC 02B .0200]. Information shall be provided orally within 24 hours (or the next business day if a weekend or holiday) from the time the applicant became aware of the circumstances. A written submission shall also be provided within 5 business days of the time the applicant becomes aware of the circumstances. The written submission shall contain a description of the noncompliance, and its causes; the period of noncompliance, including exact dates and times, if the noncompliance has not been corrected, the anticipated time compliance is expected to continue; and steps taken or planned to reduce, eliminate, and prevent reoccurrence of the noncompliance. The Division may waive the written submission requirement on a case-by-case basis.
4. All wetlands, streams, surface waters, and riparian buffers located within 50 feet of the construction area on the project site shall be clearly marked (example- orange fabric fencing) prior to any land disturbing activities and must be maintained on the property until the project phase is completed. [15A NCAC 02H .0506 (b)(2) and (c)(2) and 15A NCAC 02H .0507 (c)].

This approval and its conditions are final and binding unless contested. [G.S. 143-215.5]

This Certification can be contested as provided in Articles 3 and 4 of General Statute 150B by filing a written petition for an administrative hearing to the Office of Administrative Hearings (hereby known as OAH) **within sixty (60) calendar days**.

A petition form may be obtained from the OAH at <http://www.ncoah.com/> or by calling the OAH Clerk's Office at (919) 431-3000 for information. A petition is considered filed when the original and one (1) copy along with any applicable OAH filing fee is received in the OAH during normal office hours (Monday through Friday between 8:00am and 5:00pm, excluding official state holidays).

The petition may be faxed to the OAH at (919) 431-3100, provided the original and one copy of the petition along with any applicable OAH filing fee is received by the OAH within five (5) business days following the faxed transmission.

Mailing address for the OAH:

*If sending via US Postal Service:*

Office of Administrative Hearings  
6714 Mail Service Center  
Raleigh, NC 27699-6714

*If sending via delivery service (UPS, FedEx, etc):*

Office of Administrative Hearings  
1711 New Hope Church Road  
Raleigh, NC 27609-6285

One (1) copy of the petition must also be served to Department of Environmental Quality:

William F. Lane, General Counsel  
Department of Environmental Quality  
1601 Mail Service Center  
Raleigh, NC 27699-1601

This letter completes the review of the Division under section 401 of the Clean Water Act. Please contact Chad Turlington at 910-433-3320 or [chad.turlington@ncdenr.gov](mailto:chad.turlington@ncdenr.gov) if you have any questions or concerns.

Sincerely,

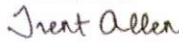
DocuSigned by:  
  
5189C2D3DD5C42B...

Trent Allen  
Regional Supervisor  
Division of Water Resources  
Water Quality Regional Operations Section

Enclosures: GC4133

Cc: Bob Zarzecki – Soil & Environmental Consultants, PA - via email  
Emily Greer - USACE Wilmington Regulatory Field Office - via email  
FRO File

# **APPENDIX C – REPORT OF SUBSURFACE EXPLORATION**

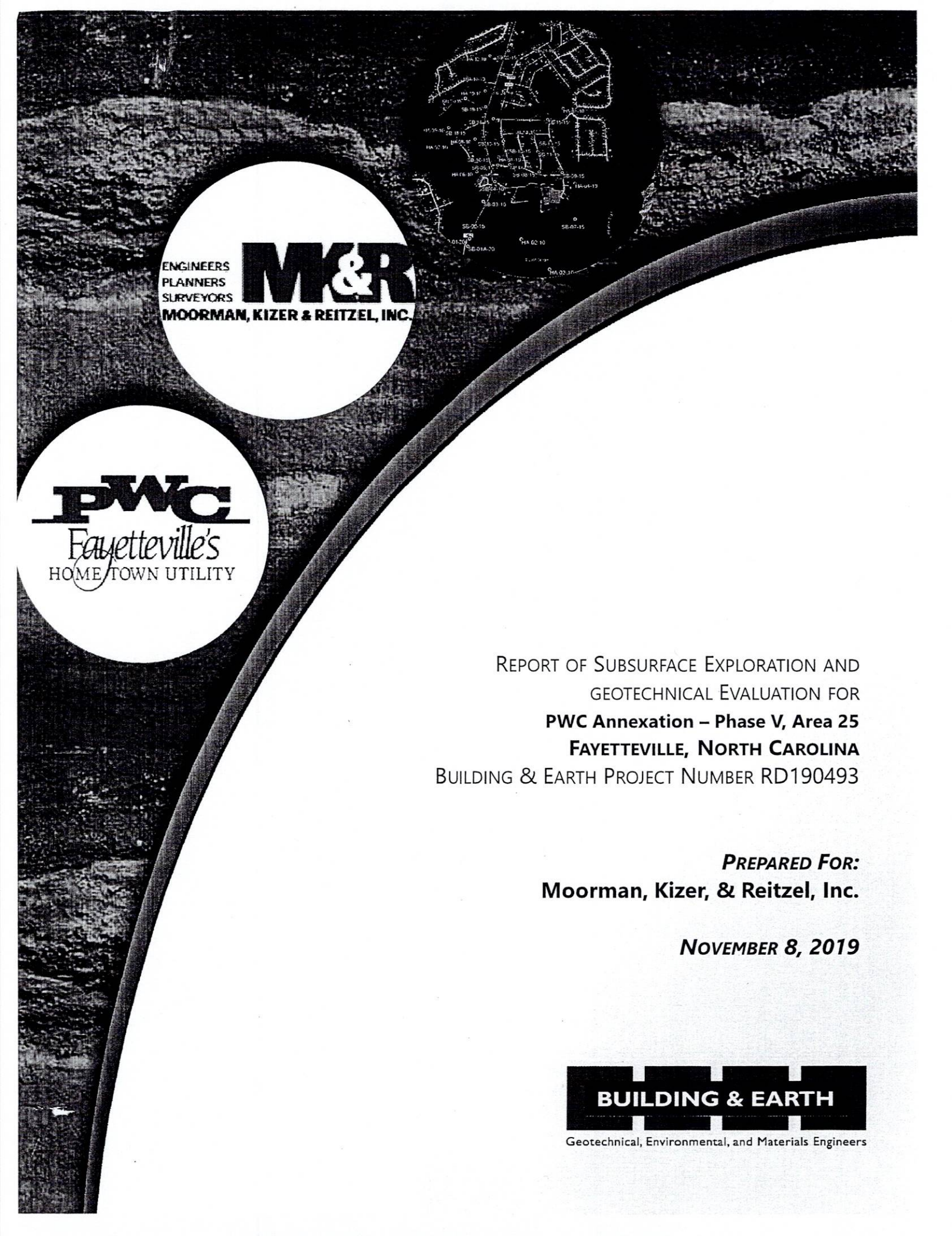

ENGINEERS  
PLANNERS  
SURVEYORS

**M&R**  
MOORMAN, KIZER & REITZEL, INC.

**PWC**  
Fayetteville's  
HOME TOWN UTILITY

REPORT OF SUBSURFACE EXPLORATION AND  
GEOTECHNICAL EVALUATION FOR  
**PWC Annexation – Phase V, Area 25**  
**FAYETTEVILLE, NORTH CAROLINA**  
BUILDING & EARTH PROJECT NUMBER RD190493

*PREPARED FOR:*  
**Moorman, Kizer, & Reitzel, Inc.**

*NOVEMBER 8, 2019*

**BUILDING & EARTH**

Geotechnical, Environmental, and Materials Engineers



Geotechnical, Environmental, and Materials Engineers

910 Spring Branch Road  
Dunn, North Carolina 28334  
Ph: (910) 292-2085  
[www.BuildingAndEarth.com](http://www.BuildingAndEarth.com)

November 8, 2019

Moorman, Kizer, & Rietzel, Inc.  
115 Broadfoot Avenue  
Fayetteville, North Carolina 28305

Attention: Mr. David Vaughn, P.E., PLS

Subject: Report of Subsurface Exploration and Geotechnical Evaluation  
PWC Annexation – Phase V, Area 25  
Fayetteville, North Carolina  
Building & Earth Project No: RD190493

Mr. Vaughn:

Building & Earth Sciences, Inc. has completed the authorized subsurface exploration and geotechnical engineering evaluation for the PWC Annexation – Phase V, Area 25 in the vicinity of Rim Road in Fayetteville, North Carolina.

The purpose of this exploration and evaluation has been to assess general subsurface conditions at the site and to address applicable geotechnical aspects of the proposed construction and site development. Recommendations in this report are based on a physical reconnaissance of the site and observation and classification of subsurface samples recovered from twenty-four (24) soil test borings and thirteen (13) hand auger test borings. One boring, initially planned as a test boring, was drilled as a hand auger boring due to limited access. Confirmation of anticipated subsurface conditions during construction is an essential part of geotechnical services.

We appreciate the opportunity to provide consultation services for the proposed project. If you have any questions regarding the information in this report or need any additional information, please call us.

Respectfully Submitted,

**BUILDING & EARTH SCIENCES, LLP.**

North Carolina Firm Engineering License Number F-1081

  
Nathan Anderson, EIT  
Field Professional II

  
Kurt A. Miller, PE  
Senior Geotechnical Engineer



  
George P. Ballock, PE (AL)  
Regional Vice President



## 1.0 PROJECT & SITE DESCRIPTION

Proposed for construction are new utility installations for residential development in the general vicinity of Rim Road, Fayetteville, North Carolina. The project is referred to as PWC Annexation – Phase V, Area 25, and will include new sanitary sewer. Installation will require directional drilling, and aerial crossing options will be evaluated for a crossing at Rim Creek. Information regarding the project is summarized in Table 1, below. Photographs depicting the site location and layout are presented on the following page.

Development Item	Detail	Description
General Site	Size (Ac.)	+/- 100 acres
	Existing Development	Residential Neighborhood
	Vegetation	Grass, Trees, Shrubs, Paved Roadways
	Drainage	Fairly well drained in residential areas – Lake and creek located along the eastern and southern portions of site

**Table 1: Project and Site Description**

Reference: "Soil Boring.pdf" & PWC Annexation – Phase V, Area 25 RFP (Provided by Dave Vaughn, PE, PLS)



**Figure 1: General Site Area (Google Earth, 9/30/2018)**



Figure 2: General Site Layout with Boring Location Overlay (Google Earth, 9/30/2018)

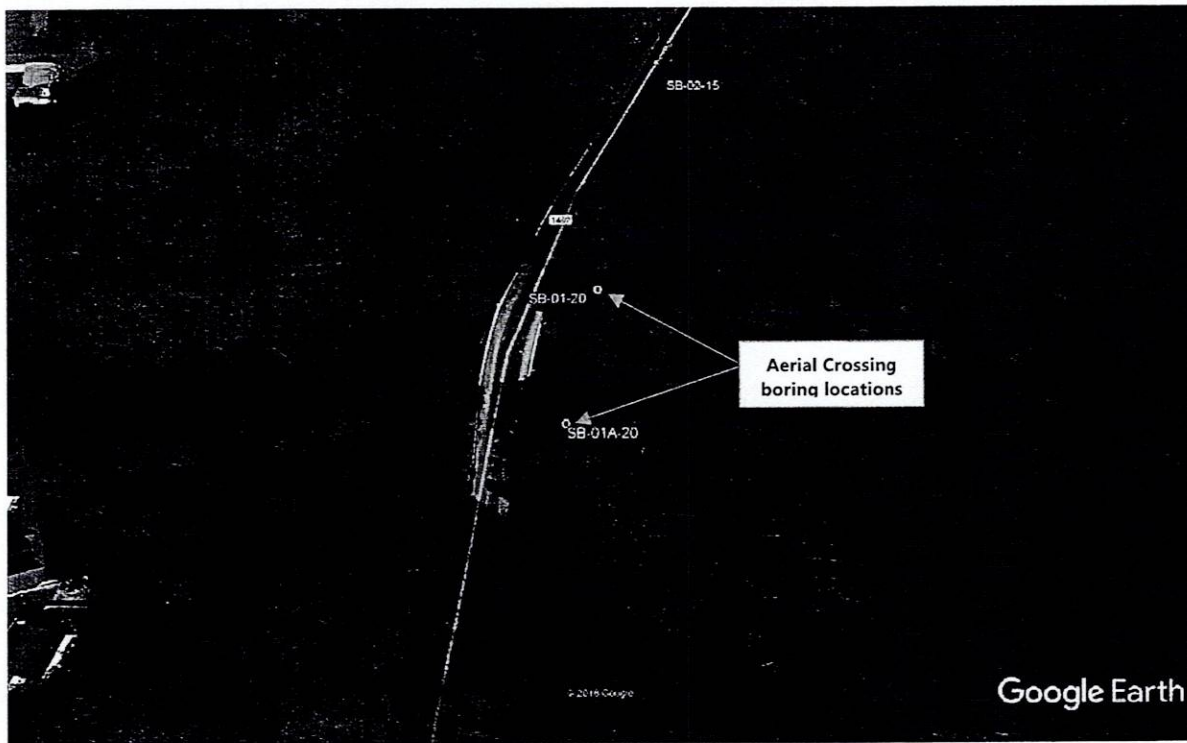

Figure 3: Potential Aerial Crossing Location (Google Earth, 9/30/2018)

## **2.0 SCOPE OF SERVICES**

The authorized subsurface exploration was performed from October 23 to November 5, 2019, in conformance with our proposal RD21556 dated September 25, 2019. Occasionally some modification to work scopes appearing in our proposals is required to provide for proper evaluation of the encountered subsurface conditions. No significant modification to our proposed scope was made for this study. However, one machine test boring, SB-07, was drilled as a hand auger boring due to limited site access.

The purpose of the geotechnical exploration has been to characterize general subsurface conditions at specific boring locations and to gather data on which to base a geotechnical evaluation with respect to the proposed construction. The subsurface exploration for this project consisted of twenty-five (25) soil test borings and twelve (12) hand auger borings. Mechanical drilling was performed using a Geoprobe 7822DT drilling rig equipped with an automatic hammer; hand drilling was performed using hand augers and a dynamic cone penetrometer.

Boring sites were located by a representative of our staff using Google Earth imagery and site plans provided by the client. As such, boring locations appearing on the attached Boring Location Plan should be considered approximate.

Soil samples recovered during our site investigation were visually classified and specific samples were selected by the project engineer for laboratory analysis. The laboratory analyses consisted of:

<b>Laboratory Test</b>	<b>Standard Method</b>	<b>No. of Tests</b>
Natural Moisture Content	ASTM D2216	32
Atterberg Limits	ASTM D4318	16
Material Finer Than No. 200 Sieve by Washing	ASTM D1140	16
Standard Proctor Compaction Test	ASTM D698	8
Laboratory Soil Corrosivity (DIPRA)	AWWA A21.5	16

**Table 2: Scope of Laboratory Tests**

Results of the laboratory analyses are presented on the attached Boring Logs and in tabular form in the report Appendix. Descriptions of laboratory tests that were performed are also included in the Appendix.

Information gathered from the exploration was evaluated to provide recommendations for the creek crossing, as well as to determine if any special subgrade preparation procedures will be required during the project earthworks phase.

Results of the work presented in this report provide or address:

- Summary of existing surface conditions.
- A description of the subsurface conditions encountered at the boring locations.
- Site preparation considerations including material types to be expected during trench excavation operations, possible undercut considerations, as well as recommendations regarding handling and treatment of unsuitable soils, if encountered.
- Dewatering recommendations, if appropriate.
- Recommendations for trench backfill including relative compaction requirements, testing frequency, and criteria to establish suitable surfaces for structural backfill.
- Recommendations for axial and lateral capacities for potential aerial crossing at creek.
- Soil parameters that can be used for directional drilling subcontractors at the potential creek crossing
- Boring logs that detail the materials encountered with soil classifications, penetration values, depth to bedrock (if encountered), and groundwater levels (if measured).
- Presentation of laboratory test results.

### **3.0 GEOTECHNICAL SITE CHARACTERIZATION**

The following paragraphs are intended to provide a general characterization of the site from a geotechnical engineering perspective. It is not the intention of this report to address every potential geotechnical issue that may arise, nor to provide every possible interpretation of conditions encountered. The following condition descriptions and subsequent geotechnical recommendations are based on the assumption significant changes in subsurface conditions do not occur between boreholes. However, anomalous conditions can occur due to variations in existing fill that may be present, or due to natural variations in site geologic conditions. It will therefore be necessary to confirm the assumed conditions as part of the various piping installation operations.

### **3.1 GEOLOGY**

Appearing on the USGS *Geologic Map of North Carolina*, the project site is situated in the North Carolina Coastal Plain, which is characterized by soils associated with the Black Creek and Cape Fear formations, which have been deposited over time as a result of erosion from rains and streams flowing toward the Atlantic Ocean. The site is underlain by non-cohesive to slightly cohesive terrace deposits and upland sediments consisting of gravel, clayey sand, and sand, primarily caused by oceanic subsidence during the Cenozoic era (65 million years of age).

The *Soil Survey of Cumberland and Hoke Counties, North Carolina* (USDA Soil Conservation Service) describes the general area as characterized by deep sedimentary soils of Cretaceous age (145 million years). Conditions encountered in borings drilled for this study generally correlate to the published geological information.

### **3.2 EXISTING SURFACE CONDITIONS**

The Phase V, Area 25 Annexation area is described as generally sloping in a northerly direction, with surface elevations ranging from approximately 160' to 230' across the site (Google Earth imagery). It is understood that various excavation and undercutting operations to existing grade will be necessary throughout the sewer installation process. Ground cover is generally grass, with small trees and shrubs that could require removal as part of site preparation operations; in the southern portion of the site, along Lake Rim, the project area is heavily wooded with mature trees. Single family dwellings, roadways, driveways, and residential structures are present across the general site location. Drainage conditions vary due to the large project footprint; storm drainage systems appear to effectively manage runoff in residential areas of the site.

From a review of historical aerial photographs (Google Earth database) the site appears to have been at least partially developed for residential purposes since at least 1992. The general configuration of the area appears to be the same since the mid 2000's.

### 3.3 SUBSURFACE CONDITIONS

A generalized stratification summary has been prepared using data from the soil test borings and is presented in the table below. The stratification depicts general soil conditions and strata types encountered during our field investigation.

Stratum No.	Typical Thickness	Description	Consistency/Relative Density
1	2 – 12 in.	<b>Asphalt or Topsoil</b>	N/A
2	0.2 – 1.2 ft.	<b>Existing Fill</b> – <i>Silty Sand (SM) or Clayey Sand (SC)</i>	Loose to Medium Dense
3	7.7 – 18.2 ft.	<b>Sandy Soils</b> – <i>Silty Sand (SM), Clayey Sand (SC), Silty Clayey Sand (SC-SM), and Poorly Graded Sand with Clay (SP-SC)</i>	Very Loose to Dense
4	6.5 – 7+ ft. (Past B.T.)	<b>Sandy Fat Clay (CH) or Fat Clay (CH)</b>	Medium Stiff to Stiff
5	1.5 – 11.5+ ft. (Past B.T.)	<b>Sandy Lean Clay (CL)</b>	Stiff to Hard

**Table 3: Stratification Summary**

Subsurface soil profiles have also been prepared based on data obtained from specific borings. The subsurface soil profiles are presented in the Appendix. For specific details regarding information obtained from individual soil borings, please refer to the Boring Logs included in the Appendix. Ground surface elevations at the boring sites, reported on the logs and elsewhere in this report, were estimated using the Google Earth elevation tool.

#### 3.3.1 ASPHALT OR TOPSOIL

Topsoil was observed at the surface in 19 of the 37 borings, with the remaining borings drilled through asphalt pavement. Topsoil depths observed in the test borings range from 2 to 12 inches; no testing has been performed to verify these soils meet general characteristics of “topsoil”. Asphalt thicknesses range between 2 and 5 inches. Topsoil and asphalt depths reported on the boring logs should only be considered an estimate, and thicknesses may vary in unexplored portions of the site

#### 3.3.2 EXISTING FILL

Fill soils were encountered in 18 borings, extending from just below the asphalt or topsoil layer to depths up to 1.5 feet below the surface. The fill is generally described as silty sand (SM) or clayey sand (SC), loose to medium dense, moist, and yellowish red. N-values in this material range from 5 to 23 blows per foot, with values in the range 8 to 15 considered representative. Low relative density soils ( $N \leq 8$ ) were encountered in borings SB-13, SB-16, SB-21, and SB-24 within this layer.

### **3.3.3 SANDY SOILS**

North Carolina Coastal Plain soils described as silty sand (SM), clayey sand (SC), silty clayey sand (SC-SM), and poorly graded sand with clay (SP-SC) were observed in all the test borings beginning just below the fill or surface layers, and extending to depths up to 20 feet below the surface. SPT N-values in this soil layer range from 1 to 35, with values in the range of 5 to 12 considered representative. Low relative density soils ( $N \leq 8$ ) were encountered at various depths throughout this layer, but typically occurred within the upper 5 feet, or in areas where soils are described as wet. Soils of this stratum are further described as very loose to dense, various shades of brown to gray, fine to medium grained, and moist to wet.

Laboratory classification testing was performed on multiple soil samples collected from this stratum. Testing indicates the fine (silt and clay fraction) has liquid limits from 15 to 57 and plasticity indices from non-plastic to 28, with 10 to 49 percent passing the No. 200 sieve. These data correspond to the following USCS classifications: SM, SC, SC-SM, or SP-SC.

### **3.3.4 SANDY FAT CLAY (CH) OR FAT CLAY (CH)**

Naturally occurring soils described as sandy fat clay or fat clay (CH) were observed in borings SB-02 and SB-09, beginning below the sandy soils and extending below the boring termination depths. SPT N-values in this layer range from 3 to 11 blows per foot. Low consistency soils (blow counts  $N \leq 8$ ) occur where the soils are described as “wet” in SB-02 (13.5 ft. depth). Soils of this stratum are further described as medium stiff to stiff, grayish brown, fine grained, and moist to wet.

Laboratory classification testing was performed on two soil samples collected from this stratum. Testing indicates the soil has liquid limits of 67 to 79 and plasticity indices of 37 to 45, with 63 to 91 percent passing the No. 200 sieve. These data correspond to a USCS “CH” classification.

### 3.3.5 SANDY LEAN CLAY (CL)

Naturally occurring soils described as sandy lean clay (CL) were observed in borings HA-05, SB-01, SB-01A, SB-05, and SB-06, beginning below the sandy soils and below the boring termination depths. N-values in stratum range from 6 to 50+ blows per foot, with values in the range of 6 to 15 considered representative. Soils of this stratum are further described as stiff to hard, gray to grayish brown, fine grained, and moist to wet.

Laboratory classification testing was performed on two soil samples collected from this stratum. Testing indicates the soil has liquid limit of 25 to 38 and plasticity indices of 11 to 20, with 63 to 66 percent passing the No. 200 sieve. These data correspond to a USCS "CL" classification.

### 3.3.6 AUGER REFUSAL

Auger refusal is the drilling depth at which a borehole cannot be advanced using soil drilling procedures. Auger refusal can occur on hard soil, boulders, buried debris, or bedrock. Coring is required to sample materials below auger refusal. Auger refusal was not encountered in test borings drilled for this study.

### 3.3.7 GROUNDWATER

At the time of drilling, groundwater was encountered in borings HA-04, HA-07, HA-09, HA-11, SB-01, SB-01A, and SB-23 at depths ranging from 4.5 to 14.9 feet below the ground surface. Twenty-four hour monitoring was performed using standpipe piezometers in borings SB-01 and SB-01A, where groundwater was measured at 5.5 and 8.6 feet, respectively. Borings SB-01 and SB-01A were backfilled about 24 hours after drilling; all other borings were backfilled on the date drilled. Groundwater data is summarized in the following table.

Boring No.	GW Depth at Time of Drilling	Elevation (Approximate)	GW Depth at 24 Hours	Elevation (Approximate)
SB-01	4.5 ft.	161.5 ft.	5.5 ft.	160.5 ft.
SB-01A	14.9 ft.	147.1 ft.	8.6 ft.	153.4 ft.
SB-02	Not measured	--	Not measured	--
SB-03	Not measured	--	Not measured	--
SB-04	Not measured	--	Not measured	--
SB-05	Not measured	--	Not measured	--
SB-06	Not measured	--	Not measured	--
SB-07	Not measured	--	Not measured	--

Table 4: Groundwater Depth (Cont'd Next Page)



Boring No.	Depth at Time of Drilling	Elevation (Approximate)	Depth at 24 Hours	Elevation (Approximate)
SB-08	Not measured	--	Not measured	--
SB-09	Not measured	--	Not measured	--
SB-10	Not measured	--	Not measured	--
SB-11	Not measured	--	Not measured	--
SB-12	Not measured	--	Not measured	--
SB-13	Not measured	--	Not measured	--
SB-14	Not measured	--	Not measured	--
SB-15	Not measured	--	Not measured	--
SB-16	Not measured	--	Not measured	--
SB-17	Not measured	--	Not measured	--
SB-18	Not measured	--	Not measured	--
SB-19	Not measured	--	Not measured	--
SB-20	Not measured	--	Not measured	--
SB-21	Not measured	--	Not measured	--
SB-22	Not measured	--	Not measured	--
SB-23	14.5 ft.	215.5 ft.	Not measured	--
SB-24	Not measured	--	Not measured	--
HA-01	Not measured	--	Not measured	--
HA-02	Not measured	--	Not measured	--
HA-03	Not measured	--	Not measured	--
HA-04	7.8 ft.	180.2 ft.	Not measured	--
HA-05	Not measured	--	Not measured	--
HA-06	Not measured	--	Not measured	--
HA-07	5.5 ft.	172.5 ft.	Not measured	--
HA-08	Not measured	--	Not measured	--
HA-09	5.5 ft.	184.5 ft.	Not measured	--
HA-10	Not measured	--	Not measured	--
HA-11	6.0 ft.	202.0 ft.	Not measured	--
HA-12	Not measured	--	Not measured	--

**Table 4: Groundwater Depth (Cont'd)**

#### **4.0 SITE DEVELOPMENT CONSIDERATIONS**

Minimal site development effort is expected as part of this project. Site development will likely include clearing of vegetation and trees, preparation of access roads to the aerial crossing site near Rim Creek, and leveling the site to accommodate pile installation or directional drilling equipment.

Although a grading plan is not available for use in preparation of this study, it is expected some minor grading will be required as part of the work. For purposes of this report, we assume no more than 2 to 3 feet of cut and fill will be required.

Crossing of the 12" water main at Rim Creek will be achieved either by use of directional drilling or a pile supported aerial crossing. Based on our evaluation of the subsurface soil information, soil parameters for use in directional drilling and pile design analysis are addressed in the *Foundation Recommendations* section of this report. ***If different foundation types or approaches to the work are preferred, Building & Earth should be allowed to review the site development recommendations to verify that they are appropriate for the preferred foundation system.***

Primary geotechnical concerns for this project are:

- Site grading to accommodate construction operations
- Variable subsurface conditions potentially affecting directional drilling operations
- Subsurface conditions at aerial crossing sites and associated pile foundation support conditions
- Moisture sensitive soils encountered across the site
- Low relative density soils encountered throughout the site, typically within the upper 5 feet

Recommendations addressing these concerns are presented in the following report sections.

#### **4.1 INITIAL SITE PREPARATION**

Where permanent grade-raise fill is required, all trees, roots, topsoil and disturbed soils and otherwise deleterious materials should be removed from the fill areas. Approximately 2 to 12 inches of topsoil were observed in nineteen (19) of the borings. A geotechnical engineer should observe stripping and grubbing operations to confirm all unsuitable materials are removed from these areas.

## **4.2 DEWATERING**

In order to install new utilities, both surface water and groundwater may need to be managed in order to maintain trenches and directional borings. This will be of particular concern where excavation operations extend through materials described as “sandy soils”. To the extent possible, managing surface water runoff should be accomplished by grading sections of the site to promote positive drainage way from active work areas. The utility contractor should evaluate the best methods of managing surface and groundwater.

Additionally, if sanitary sewer will be bedded in washed stone, there is a high potential for groundwater to drain to this stone layer, and flow to lower elevational areas of the site. Groundwater has the potential to daylight through penetrations to the stone bedding material, if groundwater pressure is allowed to rise. For this reason, the termination end of the sewer should be designed to relieve the build-up of pressure through a French drain system that is able to daylight below the lowest elevation of the stone bedding.

## **4.3 SUBGRADE EVALUATION**

Some instability of the surface soils may exist during construction, depending on climatic and other factors immediately preceding and during construction. If any soft or otherwise unstable soils are identified during construction, the geotechnical engineer of record or his representative should evaluate these and make corrective action recommendations accordingly. This evaluation will include a review of the site conditions, and providing recommendations for repair.

## **4.4 MOISTURE SENSITIVE SOILS**

Moisture sensitive sandy soils (SC, SM, SC-SM, SP-SC) and clayey soils (CL, CH) were encountered across most of the site during subsurface exploration. These soils will degrade if allowed to become saturated. Therefore, not allowing water to pond by maintaining positive drainage and temporary dewatering methods (if required) is important to help avoid degradation and softening of the soils.

The contractor should anticipate some difficulty during the project earthworks phases if soils within work areas become wet. Increased moisture levels will soften the subgrade and the soils may become unstable under the influence of construction traffic. Accordingly, construction during wet weather conditions should be avoided, as this could result in soft and unstable soil conditions that would require ground modification, such as in place stabilization or undercutting.

#### **4.5 EVALUATION OF LOW RELATIVE DENSITY SOILS**

Low relative density soils ( $N \leq 8$  for automatic hammer) were encountered in 31 of the borings, generally within 5 feet of the surface. Where these soils affect construction operations, it is recommended they be removed to a stable, suitable subgrade and replaced with compaction, or stabilized in place.

If in-place stabilization is elected, this can be achieved using a heavy (10,000 lb.) vibratory compactor. If stabilization is not viable, low relative density soils should be undercut to a stable subgrade, and replaced with structural fill. Clean, non-organic, non-saturated soils taken from the undercut area can be re-used as structural fill. The placement procedure, compaction, and composition of the structural fill should meet requirements of the *Structural Fill* section of this report.

All undercutting and stabilization work should be observed by the geotechnical engineer or a qualified representative of the geotechnical engineer. Some unsuitable or unstable areas may be present in unexplored areas of the site.

#### **4.6 CORROSION POTENTIAL**

Soil corrosivity potential for ductile-iron pipe has been estimated using the AWWA established 10-point assessment criteria (AWWA C105/A21.5-05 Table A.1: Soil-test evaluation). The test is performed by measuring soil resistivity, pH, redox potential, sulfides, and moisture, with each component assigned a value in accordance with the AWWA procedure. The sum of the assigned values for each sample provide a measure of soil corrosivity, with values exceeding 10 considered corrosive.

A total 16 samples were tested, ranging in depth from 3 to 10 feet below existing grades. Complete results of soil corrosivity testing are presented in the Appendix, and point values summarized in Table 5, below. Note: soil corrosivity rates solely addresses ductile-iron pipe and the soil environment which it will serve. The values presented do not address corrosivity associated with stray currents.

Boring No.	Depth (ft.)	Point Total	Boring No.	Depth (ft.)	Point Total
SB-01	6 – 7.5	7.5	HA-03	4 – 5	4.5
SB-01A	8.5 – 10	12	HA-04	3 – 4	14.5
SB-03	3.5 – 5	11	HA-05	4 – 5	3
SB-04	6 – 7.5	13	HA-06	5 – 6	4.5
SB-07	4 – 5	13	HA-07	5 – 6	2
SB-22	6 – 7.5	4.5	HA-09	5 – 6	4
HA-01	5 – 6	3.5	HA-11	7 – 8	2
HA-02	6 – 7	4.5	HA-12	5 – 6	3

**Table 5: Corrosion Potential Point Totals**

Note: Point totals  $\geq 10$  indicate that the soil sample is corrosive to ductile iron pipe, per AWWA Standard A21.5

#### 4.7 STRUCTURAL FILL

Requirements for structural fill on this project are as follows:

Soil Type	USCS Classification	Property Requirements	Placement Location
Sand and Gravel	GW, GP, GM, SW, SP, SM or combinations	Maximum 2" particle size	Areas where the material can be confined, and adequate drainage provided.
Clayey Sand and Gravel	SC, GC	LL<50, PI<25, $\gamma_d$ >100 pcf	All areas
Clay	CL, CH	N/A	Not recommended for use
Silt	ML, MH	N/A	Not recommended for use
On-site soils	SC, SM, SC-SM, SP-SC, CL, CH	As noted above.	SC, SM, SC-SM, and SP-SC: Areas where the material can be confined, and adequate drainage provided. CL, CH: Not recommended for use

**Table 6: Structural Fill Requirements**

Notes:

1. All structural fill should be free of vegetation, topsoil, and any other deleterious materials. The organic content of materials to be used for fill should be less than 3 percent.
2. LL indicates the soil Liquid Limit; PI indicates the soil Plasticity Index;  $\gamma_d$  indicates the maximum dry density as defined by the density standard outlined in the table below.
3. Laboratory testing of the soils proposed for fill must be performed in order to verify their conformance with the above recommendations.
4. Any fill to be placed at the site should be reviewed by the geotechnical engineer.

Placement requirements for structural fill are as follows:

Specification	Requirement
Lift Thickness	8" loose, 6" compacted
Density	98 Percent maximum per ASTM D-698
Moisture	±2 percent of optimum moisture as defined by ASTM D698 for cohesive soils. For cohesionless soils with greater than 12 percent passing the US Standard No. 200 sieve, ±3 percent of optimum moisture as defined above. Moisture requirement is waived for cohesionless soils with less than 12 percent passing the No. 200 sieve.
Density Testing Frequency	1 test per 250 linear feet, per lift

**Table 7: Structural Fill Placement Requirements**

#### **4.8 EXCAVATION CONSIDERATIONS**

All excavations performed at the site should follow OSHA guidelines for temporary excavations. Excavated soils should be stockpiled according to OSHA regulations to limit the potential cave-in of soils.

##### **4.8.1 GROUNDWATER**

Groundwater was encountered at depths of approximately 4.5 to 14.9 feet in seven of the borings. Thus, groundwater could be encountered during construction, particularly during undercutting, trenching, and directional drilling operations. The contractor must be prepared to remove groundwater seepage from excavations if encountered during construction. Excavations extending below groundwater levels will require dewatering systems (such as well points, sump pumps or trench drains). The contractor should evaluate the most economical and practical dewatering method. It should also be noted that fluctuations in the water level could occur due to seasonal variations in rainfall, specifically in the portions of the site located near existing water features.

#### **4.9 UTILITY TRENCH BACKFILL**

All utility trenches must be backfilled and compacted in the manner specified above for structural fill. It may be necessary to reduce the lift thickness to 4 to 6 inches to achieve compaction using hand-operated equipment.

#### **4.10 WET WEATHER CONSTRUCTION**

Excessive movement of construction equipment across the site during wet weather may result in ruts, which will collect rainwater, prolonging the time required to dry the subgrade soils.

During rainy periods, additional effort will be required to properly prepare the site and establish/maintain an acceptable subgrade. The difficulty will increase in areas where clay or silty soils are exposed at the subgrade elevation. Grading contractors typically postpone grading operations during wet weather to wait for conditions that are more favorable. Contractors can typically disk or aerate the upper soils to promote drying during intermittent periods of favorable weather. When deadlines restrict postponement of grading operations, additional measures such as undercutting and replacing saturated soils or stabilization can be utilized to facilitate placement of additional fill material.

#### **5.0 FOUNDATION RECOMMENDATIONS**

It is our understanding that two options are being considered to provide utility creek crossing near borings SB-01 and SB-01A; crossing of the 12" water main will be achieved either by use of directional drilling or aerial crossing supported by piles.

If driven pipe piles are the preferred method of crossing, piles should be embedded a minimum of 20-ft. below the surface. If directional drilling is chosen as the preferred method of crossing, the soil parameters presented below should be used in design. ***If actual loading conditions and load configurations exceed or differ from our design, our office should be contacted so that our recommendations can be reviewed.***

#### **5.1 DRIVEN PIPE PILES**

Pile capacity and deflection analyses were performed using field data and laboratory test results. Estimates of capacities and lateral deflections for 12 and 16-inch diameter piles embedded to 20 ft. depths are tabulated below. The analyses have been performed for single piles acting with free heads.

Pile capacities presented in the table below were estimated using conventional analysis for end bearing, and the  $\alpha$ -method for estimating skin friction. Densification of soils adjacent to the driven piles was considered in the analysis. Ultimate estimated capacities are tabulated for skin friction and end bearing. A safety factor of at least 2 is recommended for computing allowable capacities, with rounding to reflect nominal capacities within the appropriate safety factor range. Lateral deflection estimates were estimated using the Ensoft program L-Pile. A 50 ksi ultimate tensile strength steel pile is assumed.

<b>Estimated Single Driven Pile Capacity (Tons) 20 ft. Embed Depth</b>				
<b>Pile Diameter (in.)</b>	<b>Wall Thickness (in.)</b>	<b>Ultimate Axial Capacity (Kips)</b>	<b>Allowable Axial Capacity (Tons) (FS=2)</b>	<b>Lateral Deflection at Head (in.)</b>
12	0.5	38	19	0.38
16	0.5	50	25	0.22

**Table 8: Driven Pipe Pile Axial Capacities and Deflection Estimates**

*Notes:*

- 1.) Capacities are soil-pile related capacities and consideration should be given to the structural integrity of the pile member
- 2.) This capacity does not include load due to downdrag- see below

We recommend any planned fill be placed in advance of pile driving to reduce the effects of downdrag (negative friction and reduced pile working capacity). If more than five feet of fill is planned, the analysis should be re-run, incorporating negative skin friction into the pile loading. Negative skin friction is a downward shear drag acting on piles due to downward movement of surrounding soil relative to the pile. At this site, the downward drag would be caused by the placement of fill in the pile installation area, with downdrag caused by consolidation of the in-situ soils.

The pile minimum penetration depth has been selected by the design team based upon factors in addition to capacity. A 20 ft. embedment depth has been selected, and is considered appropriate; however, pile installation planning should include consideration of the estimated ultimate capacity, not the design capacity. Likewise, installation loading should be considered during pile selection. Post construction pile settlements less than 1-inch are expected.

Pile driving criteria should be established at the time of construction based on the characteristics of the pile driving hammer used, required pile capacity and driving resistance, and estimated subsurface conditions. Each pile should be driven to the desired tip elevation and driving resistance should be monitored without interruption in the driving operations.

We recommend pile driving be monitored by the geotechnical engineer or his representative. Sometimes, premature refusal occurs due to poor performance of the hammer rather than from soil resistance. Any changes in hammer blow counts should be carefully examined before making any decisions about the pile penetration.



Pile driving vibrations should be controlled to reduce the possibility of damage to nearby structures. The maximum particle velocity typically recommended to prevent damage to structures is 0.5 inch per second. Peak particle velocities in excess of 0.25 inch per second could densify near surface cohesionless soils causing cracks in structures supported on these soils. Therefore, we recommend that peak particle velocities at nearby structures be limited to 0.25 inch per second. The nearest structure appears to be located approximately 300 feet south from the proposed aerial crossing; however, a study should be performed on nearby structures prior to pile driving to document the pre-construction conditions.

Accurate records of the final tip elevation and driving resistances should be obtained during the pile driving operations. Supplemental techniques like pre-drilling or jetting may reduce the pile capacity and should be avoided. Some pile heaving may be experienced during installation of adjacent displacement type piles. It is therefore recommended that the tip elevation of the pile be recorded and if significant heave is noted after driving subsequent piles, provisions must be made for reseating.

Proper site preparation, construction techniques, and quality control are critical to the integrity of the deep foundation system. These construction efforts should be monitored and documented by a representative of the geotechnical engineer.

#### **5.1.1 PILE CAPACITY VERIFICATION**

Pile capacities should be verified at the start of construction, before production piles are installed, through dynamic pile testing with the use of a Pile Driving Analyzer™ (PDA) per ASTM D4945. Dynamic testing is more economical than static load testing and will enable several piles to be quickly tested during installation. Piles are typically tested during initial installation then re-struck at a minimum of 5 days after installation to determine capacity.

We recommend PDA demonstration piles have at least 3 feet of “stick-up” above the ground surface so that test equipment can be attached. During production pile installation, an Engineering Technician working under the direction of the Geotechnical Engineer should monitor all pile driving to verify the piles are encountering expected driving resistances and note any damage or other concerns during installation.

Prior to the start of construction, a wave equation analysis should be performed to verify the proposed driving system (i.e. hammer type/size) is capable of driving the piles to the desired depth without damage. Potential pile driving complications should be considered during the design and planning phase, and the pile driving contractor should be informed during the bid process of potential problems such as vibration concerns or possible subsurface debris.

## 5.2 DIRECTIONAL DRILLING

Horizontal directional drilling (HDD) is a trenchless utility installation technique, typically implemented in situations which conventional excavation is not practical. Directional drilling is also commonly used in circumstances where surface disturbance is invariable or must be kept to a minimum. During installation, a small diameter pilot hole is drilled along a path from one surface point to another, followed by boring and pulling at a larger diameter to support utility installation.

Directional drilling success is dependent upon maintaining open boreholes during pipe installation. Boreholes are maintained using appropriate drilling fluid mixtures and delivery pressures. These are selected by the drilling contractor based on soil conditions. Soil conditions encountered at the crossing site (SB-01 and SB-01A) are presented in tables below. Please note that these parameters are estimations based on our exploration of borings SB-01 and SB-01A; conditions may vary in unexplored portions of the site. It should also be noted that significant variation in soil gradation, clay and silt content is typical of coastal plain soils and that this variation should be considered in planning HDD operations.

Soil Parameters (SB-01)							
Depth (ft.)		Soil Type	Consistency /Relative Density	Cohesion	Angle of Internal Friction, $\phi$	Total Unit Weight, $\gamma_t$	Buoyant Unit Weight, $\gamma_b$
From	To						
0.0	8.5	Silty Sand	Loose to Very Loose	--	28°	100 pcf	37.6 pcf
8.5	13.5	Clayey Sand	Loose	0.5 ksf	30°	110 pcf	47.6 pcf
13.5	18.5	Clayey Sand	Dense	0.5 ksf	33°	115 pcf	52.6 pcf
18.5	20.0	Sandy Clay	Hard	4.0 ksf	--	125 pcf	62.6 pcf

**Table 9: HDD Soil Parameters (SB-01)**

*Notes:*

- 1.) Groundwater was encountered in SB-01 at 4.5' at time of drilling, and stabilized at 5.5' 24-hours after drilling.
- 2.) Unit weights and cohesion derived from "Foundation Analysis, Ed. 4", Bowles
- 3.) Angles of internal friction derived from Meyerhof, 1956

<b>Soil Parameters (SB-01A)</b>							
<b>Depth (ft.)</b>		<b>Soil Type</b>	<b>Consistency /Relative Density</b>	<b>Cohesion</b>	<b>Angle of Internal Friction, <math>\phi</math></b>	<b>Total Unit Weight, <math>\gamma_t</math></b>	<b>Buoyant Unit Weight, <math>\gamma_b</math></b>
<b>From</b>	<b>To</b>						
0.0	4.7	Silty Sand	Medium Dense	--	29°	115 pcf	--
4.7	8.5	Sand with Clay	Medium Dense to Loose	--	30°	110 pcf	--
8.5	10.0	Sandy Clay	Hard	3.5 ksf	--	120 pcf	57.6 pcf
10.0	15.0	Sandy Clay	Very Stiff	2 ksf	--	120 pcf	57.6 pcf
15.0	20.0	Sandy Clay	Stiff	1 ksf	--	115 pcf	52.6 pcf

**Table 10: HDD Soil Parameters (SB-01A)**

*Notes:*

- 1.) Groundwater was encountered in SB-01A at 14.9' at time of drilling, and stabilized at 8.6' 24-hours after drilling.
- 2.) Unit weights and cohesion derived from "Foundation Analysis, Ed. 4", Bowles
- 3.) Angles of internal friction derived from Meyerhof, 1956

**6.0 CONSTRUCTION MONITORING**

Field verification of site conditions is an essential part of the services provided by the geotechnical consultant. In order to confirm our recommendations, it will be necessary for Building & Earth personnel to make periodic visits during site preparation and pile installation operations. Typical construction monitoring services are listed below.

- Periodic observations and consultations by a member of our engineering staff during site grading.
- Continuous monitoring during structural fill placement or undercutting.
- Field density tests during structural fill placement.
- Monitoring and inspection of driven pile construction.

**7.0 CLOSING AND LIMITATIONS**

This report was prepared for Moorman, Kizer, & Rietzel, Inc., for specific application to the PWC Annexation – Phase V, Area 25, located in Fayetteville, North Carolina. The information in this report is not transferable. This report should not be used for a different development on the same property without first being evaluated by the engineer.

The recommendations in this report were based on the information obtained from our field exploration and laboratory analysis. The data collected is representative of the locations tested. Variations are likely to occur at other locations throughout the site. Engineering judgment was applied in regards to conditions between borings. It will be necessary to confirm the anticipated subsurface conditions during construction.

This report has been prepared in accordance with generally accepted standards of geotechnical engineering practice. No other warranty is expressed or implied. In the event that changes are made, or anticipated to be made, to the nature, design, or location of the project as outlined in this report, Building & Earth must be informed of the changes and given the opportunity to either verify or modify the conclusions of this report in writing, or the recommendations of this report will no longer be valid.

The scope of services for this project did not include any environmental assessment of the site or identification of pollutants or hazardous materials or conditions. If the owner is concerned about environmental issues Building & Earth would be happy to provide an additional scope of services to address those concerns.

This report is intended for use during design and preparation of specifications and may not address all conditions at the site during construction. Contractors reviewing this information should acknowledge that this document is for design information only.

An article published by the Geoprofessional Business Association (GBA), titled *Important Information About Your Geotechnical Report*, has been included in the Appendix. We encourage all individuals to become familiar with the article to help manage risk.

# Appendix Table of Contents

GEOTECHNICAL INVESTIGATION METHODOLOGIES .....	1
DRILLING PROCEDURES – STANDARD PENETRATION TEST (ASTM D1586) .....	1
HAND AUGER BORINGS AND DYNAMIC CONE PENETRATION TESTING .....	2
BULK SAMPLING .....	2
BORING LOG DESCRIPTION .....	3
DEPTH AND ELEVATION .....	3
SAMPLE TYPE .....	3
SAMPLE NUMBER.....	3
BLOWS PER INCREMENT, REC%, RQD%.....	3
SOIL DATA .....	3
SOIL DESCRIPTION.....	4
GRAPHIC .....	4
REMARKS.....	4
SOIL CLASSIFICATION METHODOLOGY.....	5
KEY TO LOGS .....	7
KEY TO HATCHES.....	9
BORING LOCATION PLAN.....	10
SUBSURFACE SOIL PROFILES .....	11
BORING LOGS .....	12
LABORATORY TEST PROCEDURES.....	13
DESCRIPTION OF SOILS (VISUAL-MANUAL PROCEDURE) (ASTM D2488).....	13
POCKET PENETROMETER .....	13
NATURAL MOISTURE CONTENT (ASTM D2216).....	13
ATTERBERG LIMITS (ASTM D4318) .....	13
MATERIAL FINER THAN NO. 200 SIEVE BY WASHING (ASTM D1140).....	13
STANDARD PROCTOR COMPACTION TEST (ASTM D698).....	14
WATER SOLUBLE CHLORIDE AND SULFATE, RESISTIVITY AND PH (DIPRA).....	14
LABORATORY TEST RESULTS .....	15
Table A-1: General Soil Classification Test Results.....	15
IMPORTANT INFORMATION ABOUT THIS GEOTECHNICAL-ENGINEERING REPORT.....	16

## GEOTECHNICAL INVESTIGATION METHODOLOGIES

The subsurface exploration, which is the basis of the recommendations of this report, has been performed in accordance with industry standards. Detailed methodologies employed in the investigation are presented in the following sections.

### *DRILLING PROCEDURES – STANDARD PENETRATION TEST (ASTM D1586)*

At each boring location, soil samples were obtained at standard sampling intervals with a split-spoon sampler. The borehole was first advanced to the sample depth by augering and the sampling tools were placed in the open hole. The sampler was then driven 18 inches into the ground with a 140-pound automatic hammer free-falling 30 inches. The number of blows required to drive the sampler each 6-inch increment was recorded. The initial increment is considered the "seating" blows, where the sampler penetrates loose or disturbed soil in the bottom of the borehole.

The blows required to penetrate the final two (2) increments are added together and are referred to as the Standard Penetration Test (SPT) N-value. The N-value, when properly evaluated, gives an indication of the soil's strength and ability to support structural loads. Many factors can affect the SPT N-value, so this result cannot be used exclusively to evaluate soil conditions.

The SPT testing was performed using a drill rig equipped with an automatic hammer. Automatic hammers mechanically control the height of the hammer drop, and doing so, deliver higher energy efficiency (90 to 99 % efficiency) than manual hammers (60 % efficiency) which are dropped using a manually operated rope and cathead system. Because historic data correlations were developed based on use of a manual hammer, it is necessary to adjust the N-values obtained using an automatic hammer to make these correlations valid. Therefore, an energy correction factor of 1.3 was applied to the recorded field N-values from the automatic hammer for the purpose of our evaluation. The N-values discussed or mentioned in this report and shown on the boring logs are recorded field values.

Samples retrieved from the boring locations were labeled and stored in plastic bags at the jobsite before being transported to our laboratory for analysis. The project engineer prepared Boring Logs summarizing the subsurface conditions at the boring locations.

### *HAND AUGER BORINGS AND DYNAMIC CONE PENETRATION TESTING*

Hand auger borings were drilled with a 3-inch diameter auger to advance the hole below the existing grade. A Building & Earth representative collected samples of the subsurface soils at regular depth intervals and at depths where a change in lithology occurred.

Dynamic Cone Penetration (DCP) testing was performed in the hand auger borings to evaluate the consistency of the subgrade soils. The DCP apparatus consists of a steel, cylindrical shaft with a conical tip at the end. The conical tip measures 1.5-inches in diameter, with a 45° tip angle. A 15-pound sliding ring weight is mounted to the shaft. When dropped from a height of 20 inches, the ring weight strikes a steel anvil, driving the point into the soil. After seating the point into the soil 2 inches, the weight is dropped until the shaft travels an interval of 1.75 inches. The number of blows necessary to drive the tip each 1.75-inch increment is recorded. Given the material type and certain soil properties, this number can then be correlated to the Standard Penetration Test (ASTM D1586) N-values. The DCP test results are shown under the "Remarks" column on the boring logs.

### *BULK SAMPLING*

Bulk sample are obtained for the evaluation of the compaction characteristics of the site soils and for determination of the California Bearing Ratio (CBR). The bulk samples are obtained from manual excavations, backhoe test pits, or from auger cutting. Similar soils are normally combined to provide samples of adequate size for compaction or CBR testing.

## **BORING LOG DESCRIPTION**

Building & Earth Sciences, Inc. used the gINT software program to prepare the attached boring logs. The gINT program provides the flexibility to custom design the boring logs to include the pertinent information from the subsurface exploration and results of our laboratory analysis. The soil and laboratory information included on our logs is summarized below:

### *DEPTH AND ELEVATION*

The depth below the ground surface and the corresponding elevation are shown in the first two columns.

### *SAMPLE TYPE*

The method used to collect the sample is shown. The typical sampling methods include Split Spoon Sampling, Shelby Tube Sampling, Grab Samples, and Rock Core. A key is provided at the bottom of the log showing the graphic symbol for each sample type.

### *SAMPLE NUMBER*

Each sample collected is numbered sequentially.

### *BLOWS PER INCREMENT, REC%, RQD%*

When Standard Split Spoon sampling is used, the blows required to drive the sampler each 6-inch increment are recorded and shown in column 5. When rock core is obtained the recovery ratio (REC%) and Rock Quality Designation (RQD%) is recorded.

### *SOIL DATA*

Column 6 is a graphic representation of four different soil parameters. Each of the parameters use the same graph, however, the values of the graph subdivisions vary with each parameter. Each parameter presented on column 6 is summarized below:

- N-value- The Standard Penetration Test N-value, obtained by adding the number of blows required to drive the sampler the final 12 inches, is recorded. The graph labels range from 0 to 50.
- Qu – Unconfined Compressive Strength estimate from the Pocket Penetrometer test in tons per square foot (tsf). The graph labels range from 0 to 5 tsf.
- Atterberg Limits – The Atterberg Limits are plotted with the plastic limit to the left, and liquid limit to the right, connected by a horizontal line. The difference in the plastic and liquid limits is referred to as the Plasticity Index. The Atterberg Limits test results are also included in the Remarks column on the far right of the boring log. The Atterberg Limits graph labels range from 0 to 100%.
- Moisture – The Natural Moisture Content of the soil sample as determined in our laboratory.



### *SOIL DESCRIPTION*

The soil description prepared in accordance with ASTM D2488, Visual Description of Soil Samples. The Munsel Color chart is used to determine the soil color. Strata changes are indicated by a solid line, with the depth of the change indicated on the left side of the line and the elevation of the change indicated on the right side of the line. If subtle changes within a soil type occur, a broken line is used. The Boring Termination or Auger Refusal depth is shown as a solid line at the bottom of the boring.

### *GRAPHIC*

The graphic representation of the soil type is shown. The graphic used for each soil type is related to the Unified Soil Classification chart. A chart showing the graphic associated with each soil classification is included.

### *REMARKS*

Remarks regarding borehole observations, and additional information regarding the laboratory results and groundwater observations.

Major Divisions			Symbols		Group Name & Typical Description
			Lithology	Group	
<b>Coarse Grained Soils</b>  More than 50% of material is larger than No. 200 sieve size	<b>Gravel and Gravelly Soils</b>  More than 50% of coarse fraction is larger than No. 4 sieve	<b>Clean Gravels</b> (Less than 5% fines)		<b>GW</b>	Well-graded gravels, gravel – sand mixtures, little or no fines
				<b>GP</b>	Poorly-graded gravels, gravel – sand mixtures, little or no fines
		<b>Gravels with Fines</b> (More than 12% fines)		<b>GM</b>	Silty gravels, gravel – sand – silt mixtures
				<b>GC</b>	Clayey gravels, gravel – sand – clay mixtures
	<b>Sand and Sandy Soils</b>  More than 50% of coarse fraction is smaller than No. 4 sieve	<b>Clean Sands</b> (Less than 5% fines)		<b>SW</b>	Well-graded sands, gravelly sands, little or no fines
				<b>SP</b>	Poorly-graded sands, gravelly sands, little or no fines
		<b>Sands with Fines</b> (More than 12% fines)		<b>SM</b>	Silty sands, sand – silt mixtures
				<b>SC</b>	Clayey sands, sand – clay mixtures
<b>Fine Grained Soils</b>  More than 50% of material is smaller than No. 200 sieve size	<b>Silts and Clays</b>  Liquid Limit less than 50	<b>Inorganic</b>		<b>ML</b>	Inorganic silts and very fine sands, rock flour, silty or clayey fine sands or clayey silt with slight plasticity
				<b>CL</b>	Inorganic clays of low to medium plasticity, gravelly clays, sandy clays, silty clays, lean clays
		<b>Organic</b>		<b>OL</b>	Organic silts and organic silty clays of low plasticity
	<b>Silts and Clays</b>  Liquid Limit greater than 50 sieve	<b>Inorganic</b>		<b>MH</b>	Inorganic silts, micaceous or diatomaceous fine sand, or silty soils
				<b>CH</b>	Inorganic clays of high plasticity
		<b>Organic</b>		<b>OH</b>	Organic clays of medium to high plasticity, organic silts
<b>Highly Organic Soils</b>				<b>PT</b>	Peat, humus, swamp soils with high organic contents

**Table 1: Soil Classification Chart (based on ASTM D2487)**

Building & Earth Sciences classifies soil in general accordance with the Unified Soil Classification System (USCS) presented in ASTM D2487. Table 1 and Figure 1 exemplify the general guidance of the USCS. Soil consistencies and relative densities are presented in general accordance with Terzaghi, Peck, & Mesri's (1996) method, as shown on Table 2, when quantitative field and/or laboratory data is available. Table 2 includes Consistency and Relative Density correlations with N-values obtained using either a manual hammer (60 percent efficiency) or automatic hammer (90 percent efficiency). The *Blows Per Increment* and *SPT N-values* displayed on the boring logs are the unaltered values measured in the field. When field and/or laboratory data is not available, we may classify soil in general accordance with the Visual Manual Procedure presented in ASTM D2488.

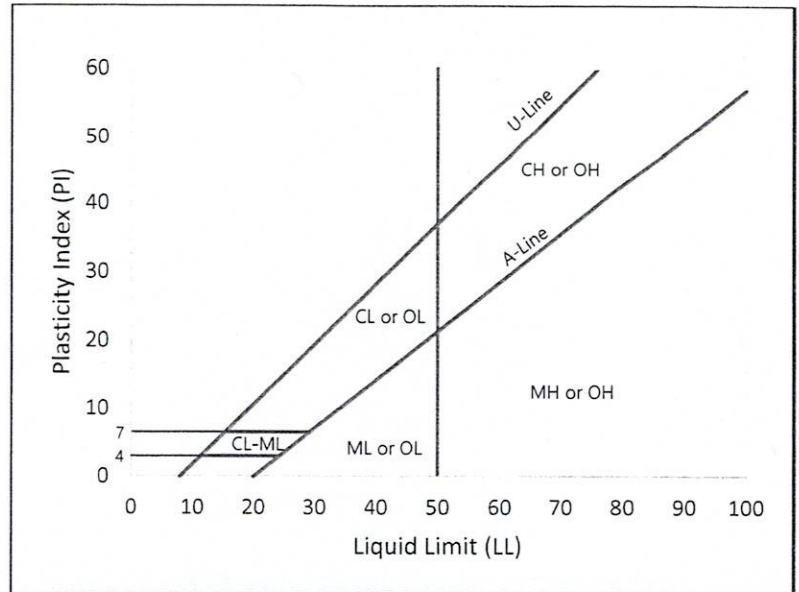









**Figure 1: Plasticity Chart (based on ASTM D2487)**

Non-cohesive: Coarse-Grained Soil		Cohesive: Fine-Grained Soil				
SPT Penetration (blows/foot)		Relative Density	SPT Penetration (blows/foot)		Consistency	Estimated Range of Unconfined Compressive Strength (tsf)
			Automatic Hammer*	Manual Hammer		
Automatic Hammer*	Manual Hammer		< 2	< 2	Very Soft	< 0.25
0 - 3	0 - 4	Very Loose	2 - 3	2 - 4	Soft	0.25 - 0.50
3 - 8	4 - 10	Loose	3 - 6	4 - 8	Medium Stiff	0.50 - 1.00
8 - 23	10 - 30	Medium Dense	6 - 12	8 - 15	Stiff	1.00 - 2.00
23 - 38	30 - 50	Dense	12 - 23	15 - 30	Very Stiff	2.00 - 4.00
> 38	> 50	Very Dense	> 23	> 30	Hard	> 4.00

**Table 2: Soil Consistency and Relative Density (based on Terzaghi, Peck & Mesri, 1996)**





\* - Modified based on 80% hammer efficiency

	Standard Penetration Test ASTM D1586 or AASHTO T-206		Dynamic Cone Penetrometer (Sower DCP) ASTM STP-399
	Shelby Tube Sampler ASTM D1587		No Sample Recovery
	Rock Core Sample ASTM D2113		Groundwater at Time of Drilling
	Auger Cuttings		Groundwater as Indicated

**Table 1: Symbol Legend**

Soil	Particle Size	U.S. Standard
<b>Boulders</b>	Larger than 300 mm	N.A.
<b>Cobbles</b>	300 mm to 75 mm	N.A.
<b>Gravel</b>	75 mm to 4.75 mm	3-inch to #4 sieve
Coarse	75 mm to 19 mm	3-inch to ¾-inch sieve
Fine	19 mm to 4.75 mm	¾-inch to #4 sieve
<b>Sand</b>	4.75 mm to 0.075 mm	#4 to #200 Sieve
Coarse	4.75 mm to 2 mm	#4 to #10 Sieve
Medium	2 mm to 0.425 mm	#10 to #40 Sieve
Fine	0.425 mm to 0.075 mm	#40 to #200 Sieve
<b>Fines</b>	Less than 0.075 mm	Passing #200 Sieve
Silt	Less than 5 µm	N.A.
Clay	Less than 2 µm	N.A.

**Table 2: Standard Sieve Sizes**

N Value 	Standard Penetration Test Resistance calculated using ASTM D1586 or AASHTO T-206. Calculated as sum of original, field recorded values.	Atterberg Limits 	A measure of a soil's plasticity characteristics in general accordance with ASTM D4318. The soil Plasticity Index (PI) is representative of this characteristic and is bracketed by the Liquid Limit (LL) and the Plastic Limit (PL).
Qu 	Unconfined compressive strength, typically estimated from a pocket penetrometer. Results are presented in tons per square foot (tsf).	% Moisture 	Percent natural moisture content in general accordance with ASTM D2216.

**Table 3: Soil Data**

Hollow Stem Auger	Flights on the outside of the shaft advance soil cuttings to the surface. The hollow stem allows sampling through the middle of the auger flights.
Mud Rotary / Wash Bore	A cutting head advances the boring and discharges a drilling fluid to support the borehole and circulate cuttings to the surface.
Solid Flight Auger	Flights on the outside bring soil cuttings to the surface. Solid stem requires removal from borehole during sampling.
Hand Auger	Cylindrical bucket (typically 3-inch diameter and 8 inches long) attached to a metal rod and turned by human force.

**Table 4: Soil Drilling Methods**

Descriptor	Meaning
Trace	Likely less than 5%
Few	5 to 10%
Little	15 to 25%
Some	30 to 45%
Mostly	50 to 100%

**Table 5: Descriptors**

<b>Manual Hammer</b>	The operator tightens and loosens the rope around a rotating drum assembly to lift and drop a sliding, 140-pound hammer falling 30 inches.
<b>Automatic Trip Hammer</b>	An automatic mechanism is used to lift and drop a sliding, 140-pound hammer falling 30 inches.
<b>Dynamic Cone Penetrometer (Sower DCP) ASTM STP-399</b>	Uses a 15-pound steel mass falling 20 inches to strike an anvil and cause penetration of a 1.5-inch diameter cone seated in the bottom of a hand augered borehole. The blows required to drive the embedded cone a depth of 1-3/4 inches have been correlated by others to N-values derived from the Standard Penetration Test (SPT).

**Table 6: Sampling Methods**

<b>Non-plastic</b>	A 1/8-inch thread cannot be rolled at any water content.
<b>Low</b>	The thread can barely be rolled and the lump cannot be formed when drier than the plastic limit.
<b>Medium</b>	The thread is easy to roll and not much time is required to reach the plastic limit. The thread cannot be re-rolled after reaching the plastic limit. The lump crumbles when drier than the plastic limit.
<b>High</b>	It takes considerable time rolling and kneading to reach the plastic limit. The thread can be re-rolled several times after reaching the plastic limit. The lump can be formed without crumbling when drier than the plastic limit.

**Table 7: Plasticity**

<b>Dry</b>	Absence of moisture, dusty, dry to the touch.
<b>Moist</b>	Damp but no visible water.
<b>Wet</b>	Visible free water, usually soil is below water table.

**Table 8: Moisture Condition**

<b>Stratified</b>	Alternating layers of varying material or color with layers at least 1/2 inch thick.
<b>Laminated</b>	Alternating layers of varying material or color with layers less than 1/4 inch thick.
<b>Fissured</b>	Breaks along definite planes of fracture with little resistance to fracturing.
<b>Slickensides</b>	Fracture planes appear polished or glossy, sometimes striated.
<b>Blocky</b>	Cohesive soil that can be broken down into small angular lumps which resist further breakdown.
<b>Lensed</b>	Inclusion of small pockets of different soils, such as small lenses of sand scattered through a mass of clay.
<b>Homogeneous</b>	Same color and appearance throughout.

**Table 9: Structure**

Hatch	Description	Hatch	Description	Hatch	Description
	<b>GW</b> - Well-graded gravels, gravel – sand mixtures, little or no fines		Asphalt		Clay with Gravel
	<b>GP</b> - Poorly-graded gravels, gravel – sand mixtures, little or no fines		Aggregate Base		Sand with Gravel
	<b>GM</b> - Silty gravels, gravel – sand – silt mixtures		Topsoil		Silt with Gravel
	<b>GC</b> - Clayey gravels, gravel – sand – clay mixtures		Concrete		Gravel with Sand
	<b>SW</b> - Well-graded sands, gravelly sands, little or no fines		Coal		Gravel with Clay
	<b>SP</b> - Poorly-graded sands, gravelly sands, little or no fines		<b>CL-ML</b> - Silty Clay		Gravel with Silt
	<b>SM</b> - Silty sands, sand – silt mixtures		Sandy Clay		Limestone
	<b>SC</b> - Clayey sands, sand – clay mixtures		Clayey Chert		Chalk
	<b>ML</b> - Inorganic silts and very fine sands, rock flour, silty or clayey fine sands or clayey silt with slight plasticity		Low and High Plasticity Clay		Siltstone
	<b>CL</b> - Inorganic clays of low to medium plasticity, gravelly clays, sandy clays, silty clays, lean clays		Low Plasticity Silt and Clay		Till
	<b>OL</b> - Organic silts and organic silty clays of low plasticity		High Plasticity Silt and Clay		Sandy Clay with Cobbles and Boulders
	<b>MH</b> - Inorganic silts, micaceous or diatomaceous fine sand, or silty soils		Fill		Sandstone with Shale
	<b>CH</b> - Inorganic clays of high plasticity		Weathered Rock		Coral
	<b>OH</b> - Organic clays of medium to high plasticity, organic silts		Sandstone		Boulders and Cobbles
	<b>PT</b> - Peat, humus, swamp soils with high organic contents		Shale		Soil and Weathered Rock

**Table 1: Key to Hatches Used for Boring Logs and Soil Profiles**

# BORING LOCATION PLAN

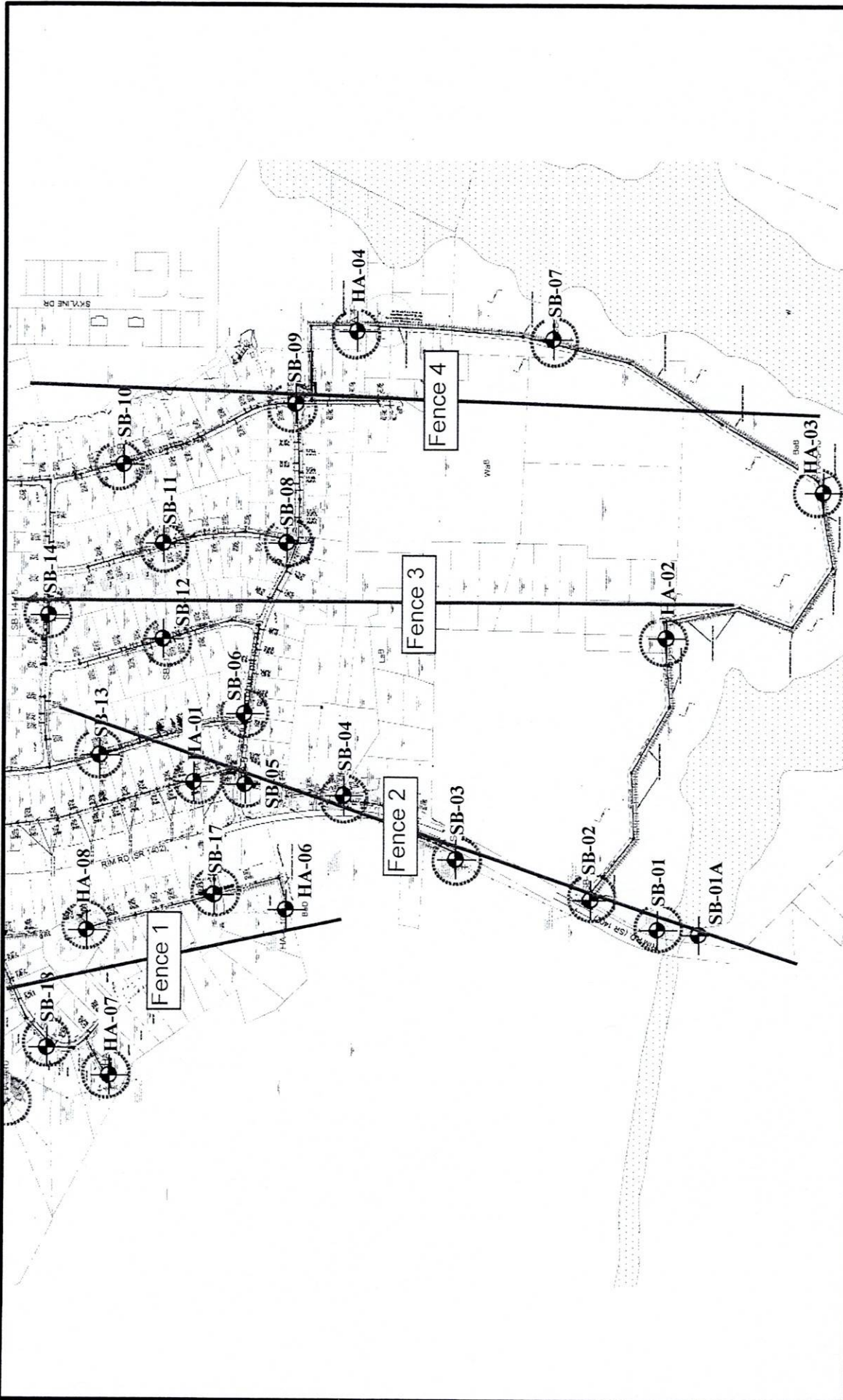

Boring Location

**Boring Location Map South**

<b>BES Project #:</b>	RD190493	<b>Address:</b>	Rim Road
<b>Drawing Source:</b>	<b>Soil Boring Locations</b>	<b>City:</b>	Fayetteville, NC
<b>Client:</b>	Moorman, Kizer, & Reitzel, Inc.	<b>Figure 1</b>	
<b>Project:</b>	PWC Annexation – Phase V, Area 25		





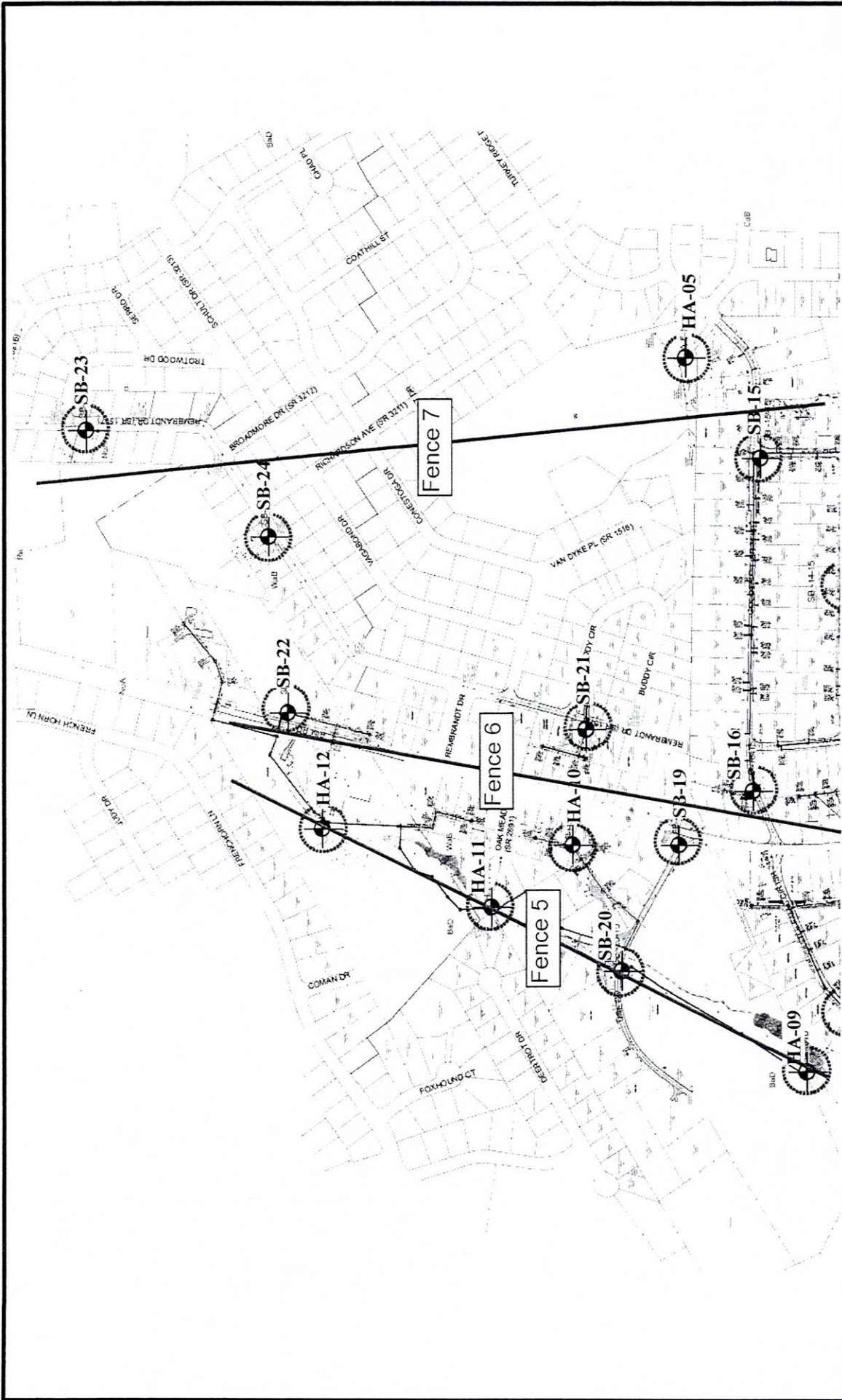

 Boring Location

**Boring Location Map North**

<b>BUILDING &amp; EARTH</b>	<b>BES Project #:</b>	RD190493	<b>Address:</b>	Rim Road
	<b>Drawing Source:</b>	<b>Soil Boring Locations</b>	<b>City:</b>	Fayetteville, NC
	<b>Client:</b>	Moorman, Kizer, & Reitzel, Inc.	<b>Figure 2</b>	
<b>Project:</b>	PWC Annexation – Phase V, Area 25			

# SUBSURFACE SOIL PROFILES

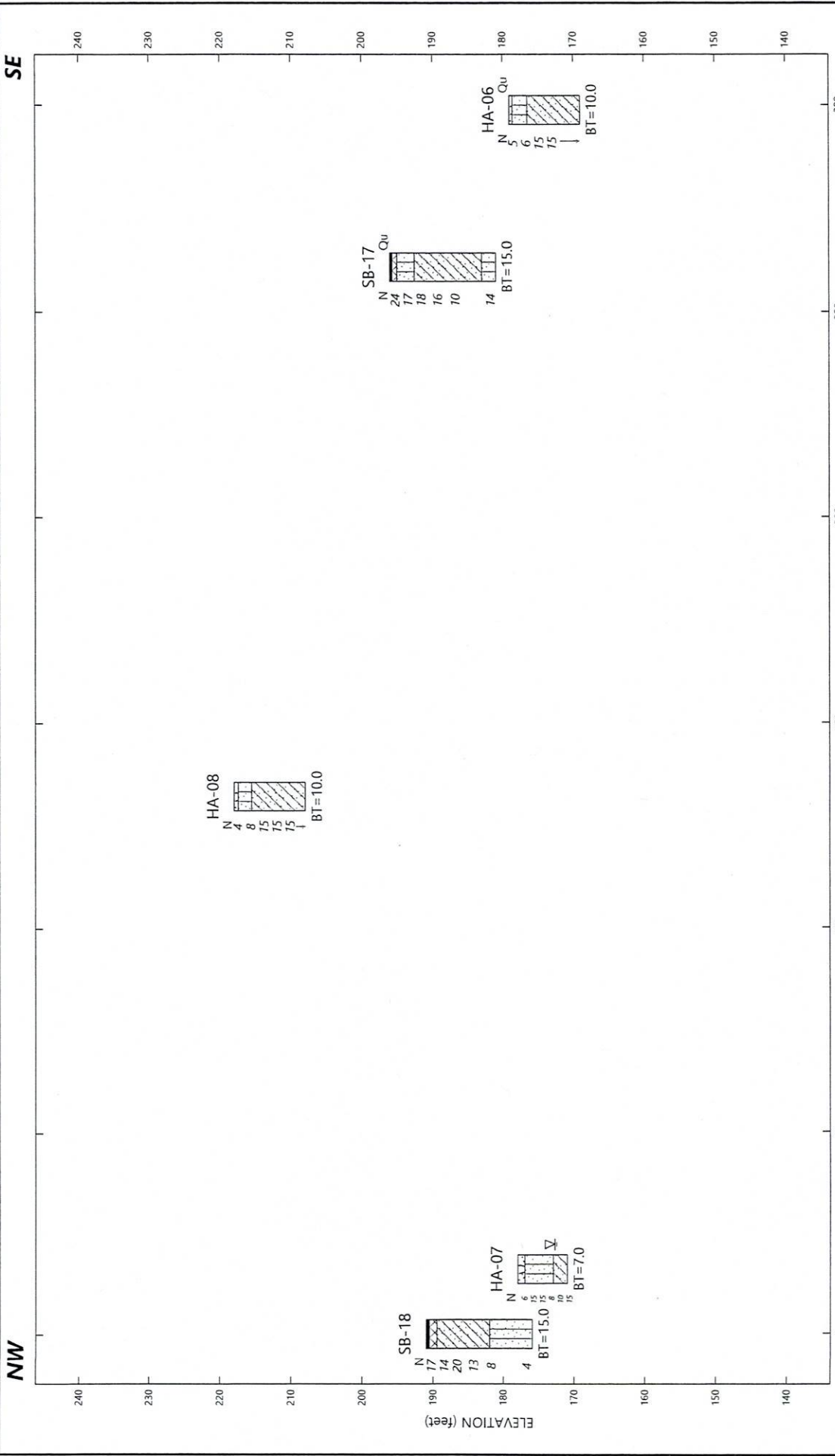

**Building & Earth Sciences, Inc.**  
 610 Spring Branch Road, Dunn, NC 28334

PWC Annexation - Phase V, Area 25  
 Fayetteville, NC

**Fence 1 : Subsurface Profile**  
**(See Boring Location Map South)**

PROJECT NO: RD190493 | PLATE NO: A-1 | DATE: 11/6/19

**BUILDING & EARTH**  
 Geotechnical, Environmental, and Materials Engineers

**Legend**

BT=Boring Termination, TPT= Test Pit Terminated  
 AR=Auger Refusal, ER=Excavation Refusal  
 N=Standard Penetration Test N-Value  
 Qu=Unconfined compressive strength estimate from pocket penetrometer test (tsf)  
 Water Level Reading at time of drilling.  
 Water Level Reading after drilling.

**Key to Hatches**

Topsoil  
 Asphalt  
 USCS Silty Sand  
 USCS Clayey Sand  
 Fill

0 36  
 Horizontal Scale (feet)  
 Vertical Exaggeration: 1.5x

**Site Map**  
 Scale 1 inch equals 130 feet

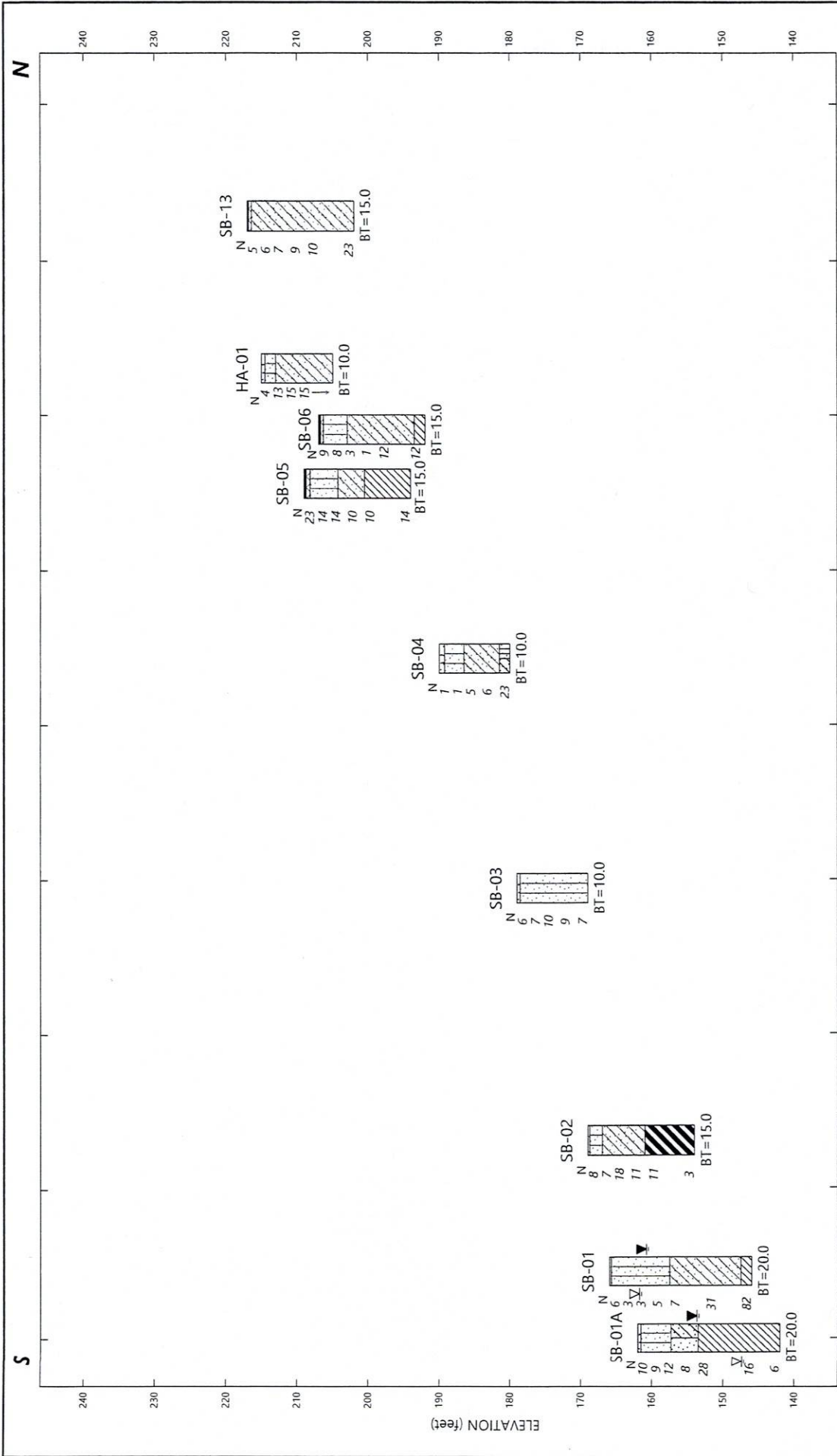

**Building & Earth Sciences, Inc.**  
 610 Spring Branch Road, Dunn, NC 28334  
 PWC Annexation - Phase V, Area 25  
 Fayetteville, NC

**Fence 2 : Subsurface Profile**  
 (See Boring Location Map South)

PROJECT NO: RD190493 | PLATE NO: A-2 | DATE: 11/6/19

**BUILDING & EARTH**  
 Geotechnical, Environmental, and Materials Engineers

**Key to Hatches**

- Topsoil
- USCS Low Plasticity Clay
- USCS Silty Clayey Sand
- USCS Silty Sand
- USCS Clayey Sand
- USCS Poorly-graded Sand with Clay
- USCS High Plasticity Clay
- Asphalt
- Fill

**Legend**

- BT=Boring Termination, TPT=Test Pit Terminated
- AR=Auger Refusal, ER=Excavation Refusal
- N=Standard Penetration Test N-Value
- Qu=Unconfined compressive strength estimate from pocket penetrometer test (tsf)
- Water Level Reading at time of drilling.
- Water Level Reading after drilling.

0 95  
 Horizontal Scale (feet)  
 Vertical Exaggeration: 4.5x

**Site Map Scale: 1 inch equals 345 feet**

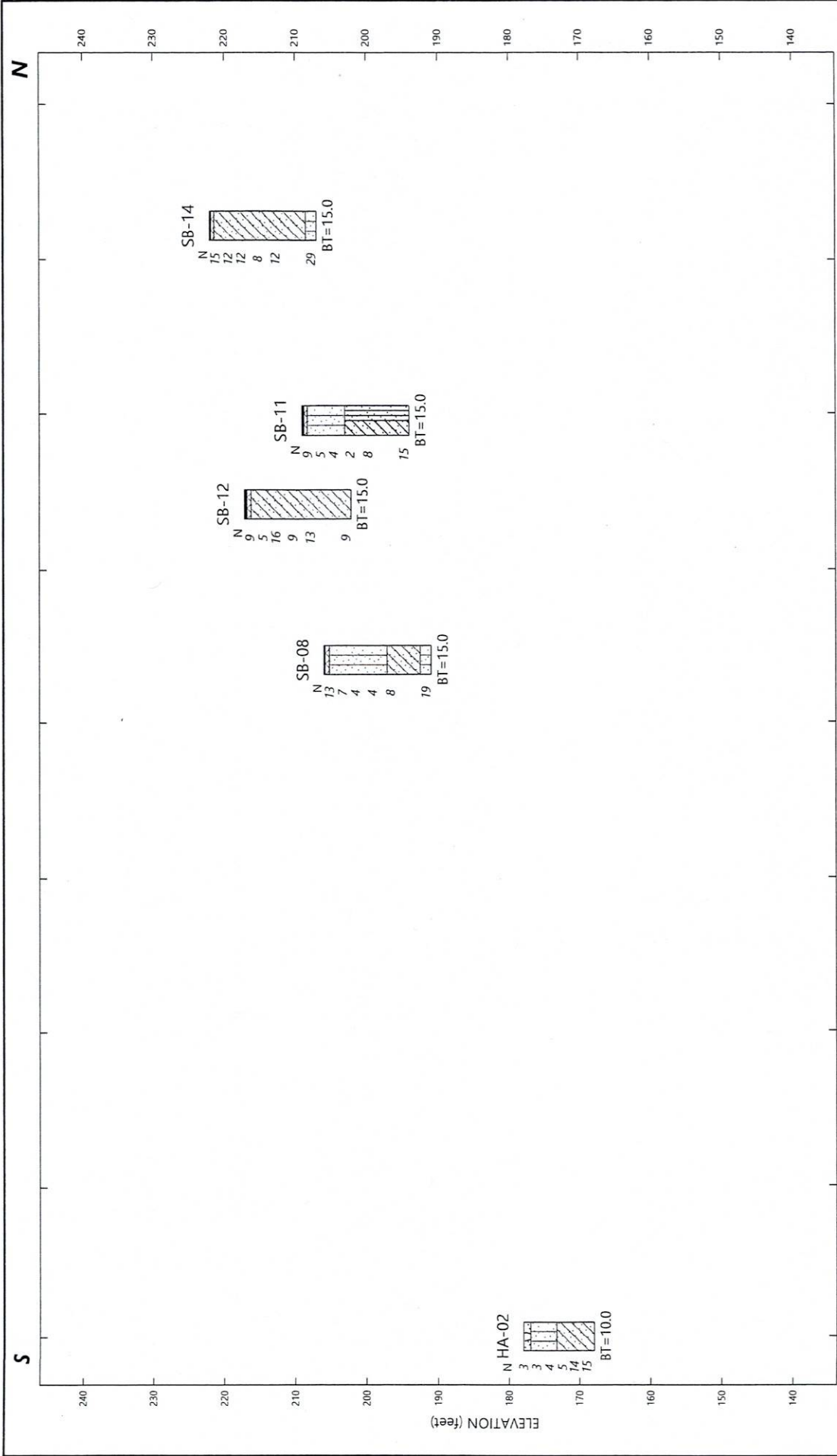

**Building & Earth Sciences, Inc.**  
 610 Spring Branch Road, Dunn, NC 28334

PWC Annexation - Phase V, Area 25  
 Fayetteville, NC

**Fence 3 : Subsurface Profile**  
 (See Boring Location Map South)

PROJECT NO: RD190493 | PLATE NO: A-3 | DATE: 11/6/19

**BUILDING & EARTH**  
 Geotechnical, Environmental, and Materials Engineers

**Legend**

BT=Boring Termination, TPT=Test Pit Terminated  
 AR=Auger Refusal, ER=Excavation Refusal  
 N=Standard Penetration Test N-Value  
 Qu=Unconfined compressive strength estimate from pocket penetrometer test (tsf)  
 ▽ Water Level Reading at time of drilling.  
 ▾ Water Level Reading after drilling.

**Key to Hatches**

- Topsoil
- Asphalt
- USCS Silty Sand
- USCS Clayey Sand
- USCS Silty Clayey Sand
- Fill

0 95  
 Horizontal Scale (feet)  
 Vertical Exaggeration: 4.5x

Site Map Scale: 1 inch equals 345 feet

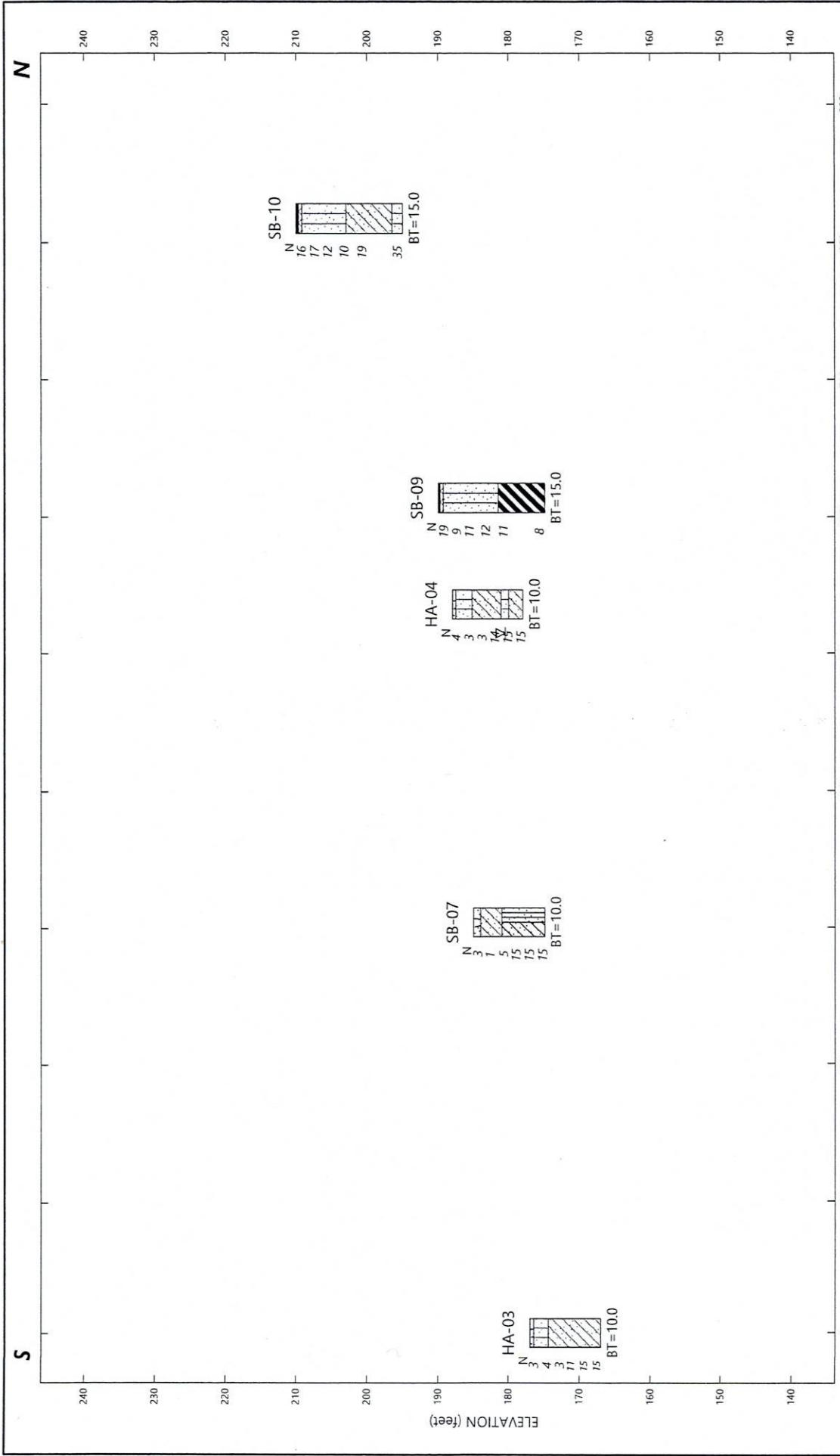

**Building & Earth Sciences, Inc.**  
610 Spring Branch Road, Dunn, NC 28334

PWC Annexation - Phase V, Area 25  
Fayetteville, NC

**Fence 4 : Subsurface Profile**  
(See Boring Location Map South)

PROJECT NO: RD190493 | PLATE NO: A-4 | DATE: 11/6/19

**BUILDING & EARTH**  
Geotechnical, Environmental, and Materials Engineers

**Key to Hatches**

- Topsoil
- USCS Silty Clayey Sand
- USCS Silty Sand
- USCS Clayey Sand
- Asphalt
- USCS Silty Clayey Sand
- USCS High Plasticity Clay
- Fill

**Legend**

- BT=Boring Termination, TPT= Test Pit Terminated
- AR=Auger Refusal, ER=Excavation Refusal
- N=Standard Penetration Test N-Value
- Qu=Unconfined compressive strength estimate from pocket penetrometer test (tsf)
- Water Level Reading at time of drilling.
- Water Level Reading after drilling.

0 107  
Horizontal Scale (feet)  
Vertical Exaggeration: 5x

Site Map Scale 1 inch equals 390 feet

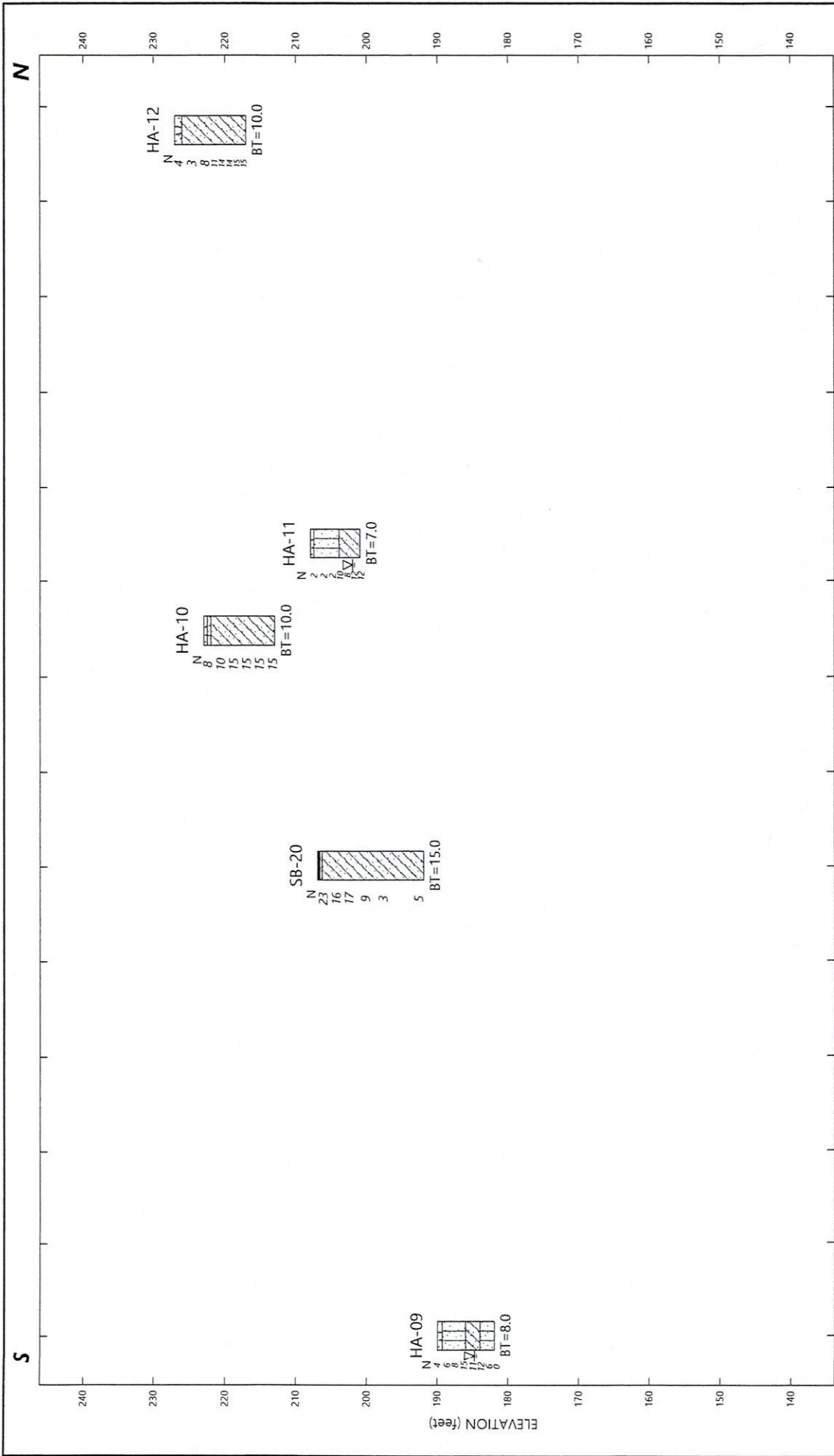

**Building & Earth Sciences, Inc.**  
610 Spring Branch Road, Dunn, NC 28334

PWC Annexation - Phase V, Area 25  
Fayetteville, NC

**Fence 5 : Subsurface Profile**  
(See Boring Location Map North)

PROJECT NO: RD190493 | PLATE NO: A-5 | DATE: 11/6/19

**BUILDING & EARTH**  
Geotechnical, Environmental, and Materials Engineers

**Key to Hatches**

- Topsoil
- USCS Silty Sand
- USCS Clayey Sand
- Asphalt
- Fill

**Legend**

- BT = Boring Termination, TPT = Test Pit Terminated
- AR = Auger Refusal, ER = Excavation Refusal
- N = Standard Penetration Test N-Value
- Qu = Unconfined compressive strength estimate from pocket penetrometer test (tsf)
- Water Level Reading at time of drilling.
- Water Level Reading after drilling.

0 77  
Horizontal Scale (feet)  
Vertical Exaggeration: 4x

Site Map Scale 1 inch equals 280 feet

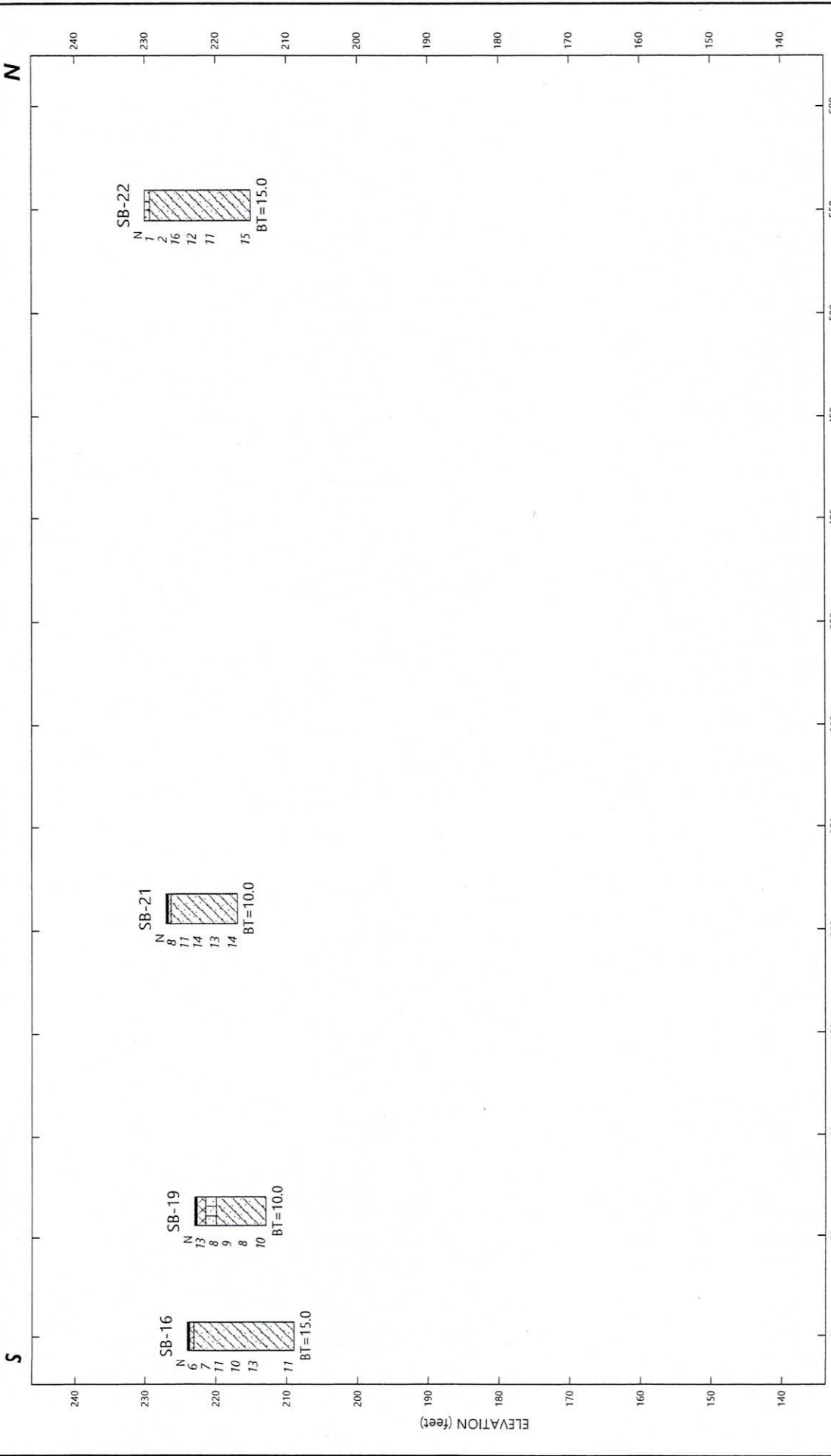

**Building & Earth Sciences, Inc.**  
610 Spring Branch Road, Dunn, NC 28334

PWC Annexation - Phase V, Area 25  
Fayetteville, NC

**Fence 6 : Subsurface Profile**  
(See Boring Location Map North)

PROJECT NO: RD190493 | PLATE NO: A-6 | DATE: 11/6/19

**BUILDING & EARTH**  
Geotechnical, Environmental, and Materials Engineers

**Legend**

BT=Boring Termination, TPT=Test Pit Terminated  
AR=Auger Refusal, ER=Excavation Refusal  
N=Standard Penetration Test N-Value  
Qu=Unconfined compressive strength estimate from pocket penetrometer test (tsf)  
▽ Water Level Reading at time of drilling.  
▼ Water Level Reading after drilling.

**Key to Hatches**

- Asphalt
- USCS Silty Sand
- USCS Clayey Sand
- Fill
- Topsoil

0 71  
Horizontal Scale (feet)  
Vertical Exaggeration: 3.5x

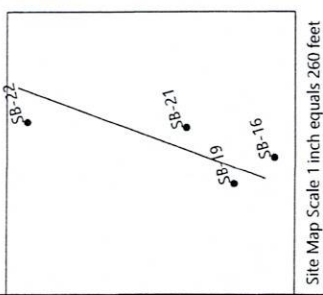



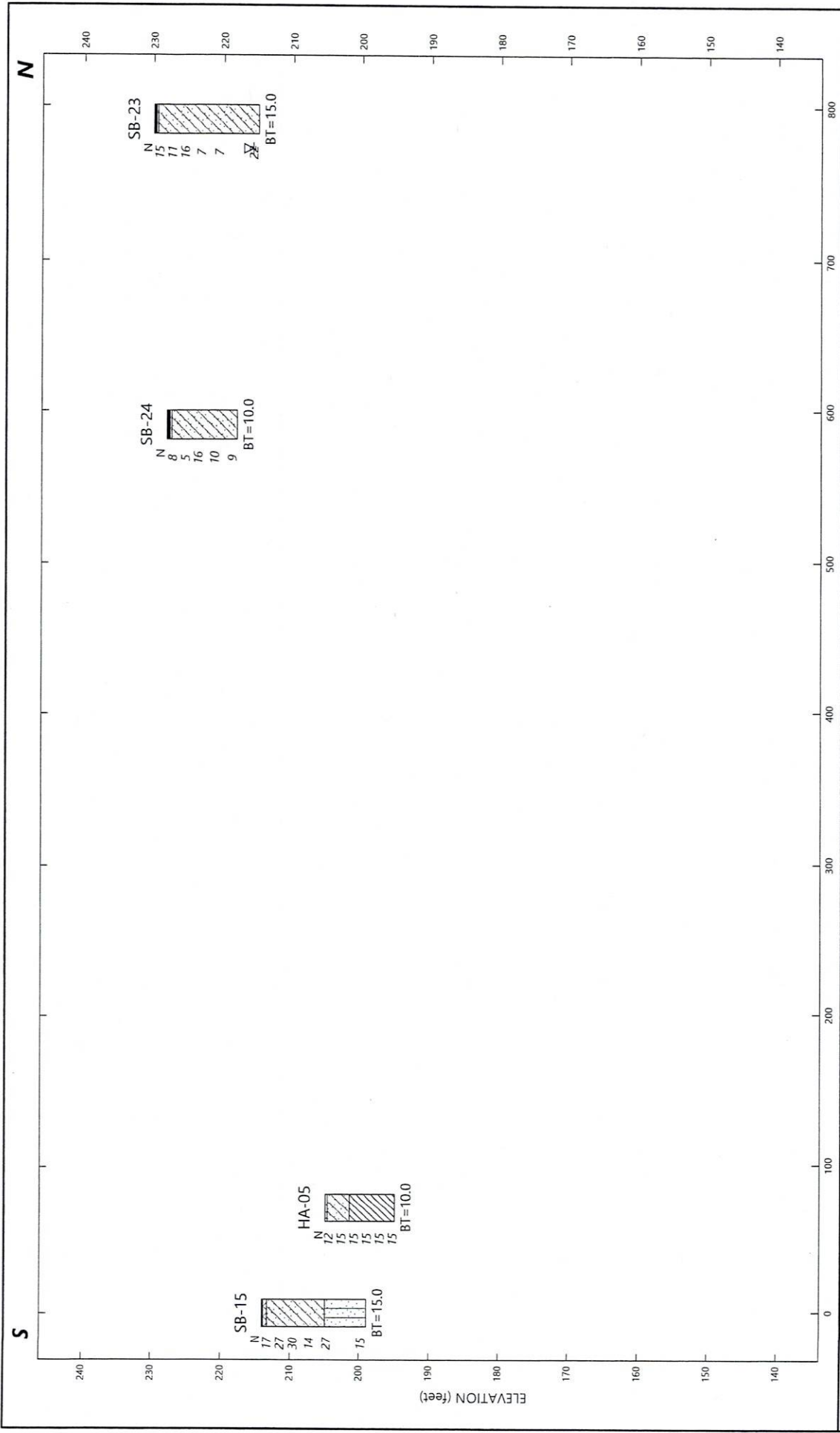

**Building & Earth Sciences, Inc.**  
 610 Spring Branch Road, Dunn, NC 28334  
 PWC Annexation - Phase V, Area 25  
 Fayetteville, NC

**Fence 7 : Subsurface Profile**  
 (See Boring Location Map North)

PROJECT NO: RD190493 | PLATE NO: A-7 | DATE: 11/6/19

**BUILDING & EARTH**  
 Geotechnical, Environmental, and Materials Engineers

**Key to Hatches**

- Topsoil
- Asphalt
- USCS Clayey Sand
- USCS Low plasticity Clay
- USCS Silty Sand
- Fill

**Legend**

- BT=Boring Termination, TPT=Test Pit Terminated
- AR=Auger Refusal, ER=Excavation Refusal
- N=Standard Penetration Test N-Value
- Qu=Unconfined compressive strength estimate from pocket penetrometer test (tsf)
- Water Level Reading at time of drilling.
- Water Level Reading after drilling.

0 95  
 Horizontal Scale (feet)  
 Vertical Exaggeration: 4.5x

Site Map Scale 1 inch equals 345 feet

# BORING LOGS



PROJECT NAME: PWC Annexation - Phase V, Area 25  
PROJECT NUMBER: RD190493  
DRILLING METHOD: Hollow Stem Auger  
EQUIPMENT USED: GeoProbe 7822DT  
HAMMER TYPE: Automatic  
BORING LOCATION: Aerial Crossing (South)

LOCATION: Fayetteville, NC  
DATE DRILLED: 10/25/19  
WEATHER: 70's, Partly Sunny  
ELEVATION: 162  
DRILL CREW: Quantex  
LOGGED BY: M.Lumpkin

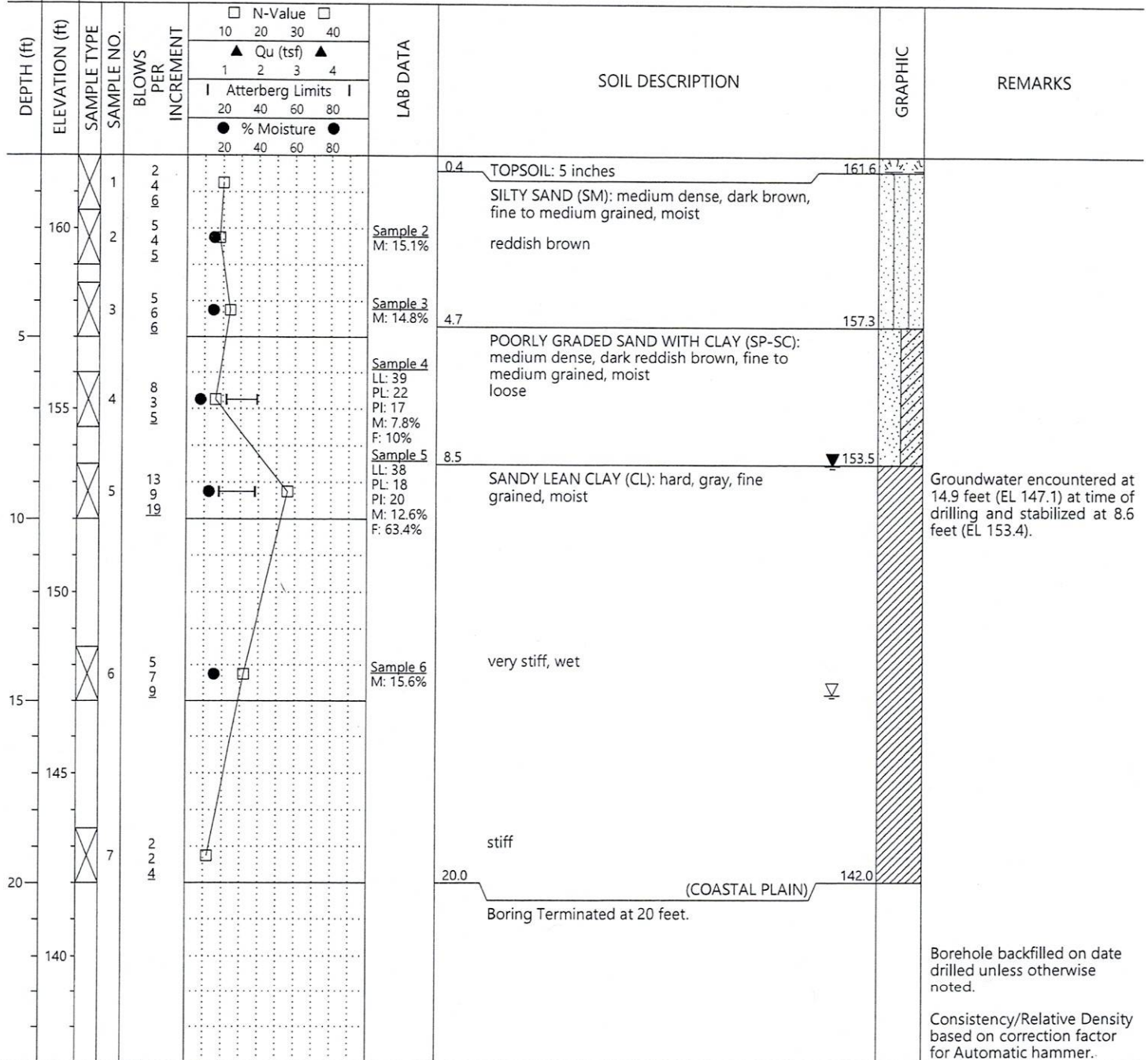

SAMPLE TYPE  Split Spoon

**N-VALUE** STANDARD PENETRATION RESISTANCE (AASHTO T-206)

**% MOISTURE** PERCENT NATURAL MOISTURE CONTENT

GROUNDWATER LEVEL IN THE BOREHOLE AT TIME OF DRILLING

STABILIZED GROUNDWATER LEVEL

**REC** RECOVERY

**RQD** ROCK QUALITY DESIGNATION

**UD** UNDISTURBED

**Qu** POCKET PENETROMETER UNCONFINED COMPRESSIVE STRENGTH

**LL:** LIQUID LIMIT **M:** NATURAL MOISTURE CONTENT

**PL:** PLASTIC LIMIT **F:** PERCENT PASSING NO. 200 SIEVE

**PI:** PLASTICITY INDEX

Borehole backfilled on date drilled unless otherwise noted.  
Consistency/Relative Density based on correction factor for Automatic hammer.

PROJECT NAME: PWC Annexation - Phase V, Area 25  
PROJECT NUMBER: RD190493  
DRILLING METHOD: Hollow Stem Auger  
EQUIPMENT USED: GeoProbe 7822DT  
HAMMER TYPE: Automatic  
BORING LOCATION: See Boring Location Map (South)

LOCATION: Fayetteville, NC  
DATE DRILLED: 10/25/19  
WEATHER: 70's, Partly Sunny  
ELEVATION: 169  
DRILL CREW: Quantex  
LOGGED BY: M.Lumpkin

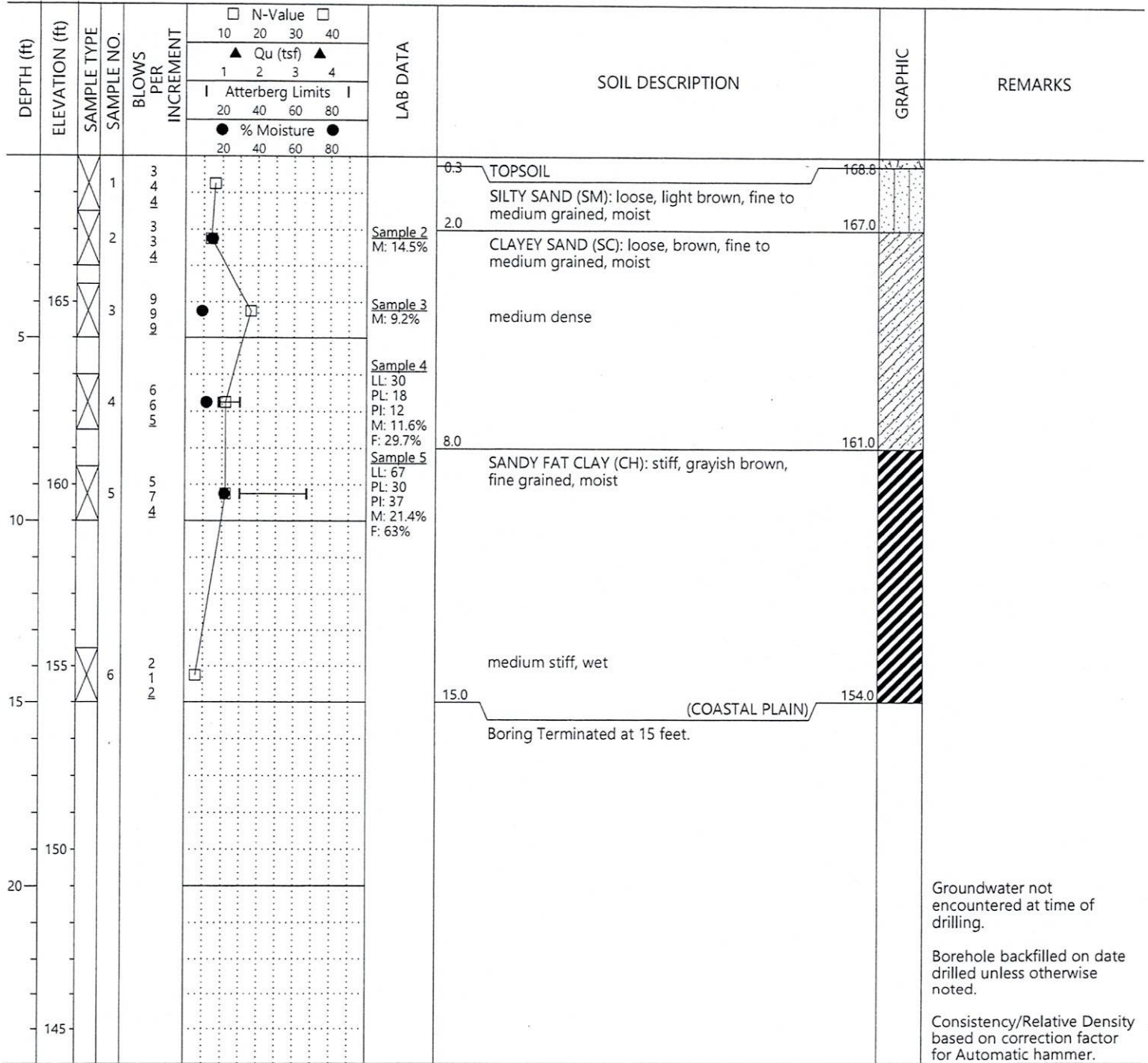

SAMPLE TYPE  Split Spoon

**N-VALUE** STANDARD PENETRATION RESISTANCE (AASHTO T-206)

**% MOISTURE** PERCENT NATURAL MOISTURE CONTENT

GROUNDWATER LEVEL IN THE BOREHOLE AT TIME OF DRILLING

STABILIZED GROUNDWATER LEVEL

**REC** RECOVERY

**RQD** ROCK QUALITY DESIGNATION

**UD** UNDISTURBED

**Qu** POCKET PENETROMETER UNCONFINED COMPRESSIVE STRENGTH

**LL:** LIQUID LIMIT **M:** NATURAL MOISTURE CONTENT

**RQD** ROCK QUALITY DESIGNATION **PL:** PLASTIC LIMIT **F:** PERCENT PASSING NO. 200 SIEVE

**PI:** PLASTICITY INDEX

PROJECT NAME: PWC Annexation - Phase V, Area 25  
 PROJECT NUMBER: RD190493  
 DRILLING METHOD: Hollow Stem Auger  
 EQUIPMENT USED: GeoProbe 7822DT  
 HAMMER TYPE: Automatic  
 BORING LOCATION: See Boring Location Map (South)

LOCATION: Fayetteville, NC  
 DATE DRILLED: 10/25/19  
 WEATHER: 70's, Partly Sunny  
 ELEVATION: 179  
 DRILL CREW: Quantex  
 LOGGED BY: M.Lumpkin

DEPTH (ft)	ELEVATION (ft)	SAMPLE TYPE	SAMPLE NO.	BLOWS PER INCREMENT	N-Value				LAB DATA	SOIL DESCRIPTION	GRAPHIC	REMARKS
					10	20	30	40				
					▲ Qu (tsf) ▲ 1 2 3 4   Atterberg Limits   20 40 60 80 ● % Moisture ● 20 40 60 80							
	179		1	2						0.4	TOPSOIL: 5 inches	178.6
			2	3							SILTY SAND (SM): loose, reddish brown, fine to medium grained, moist	
			3	3							medium dense	
			4	4								
	170		5	11						10.0	loose	169.0
				3							(COASTAL PLAIN)	
				4							Boring Terminated at 10 feet.	
	165											
	160											
	20											Groundwater not encountered at time of drilling.
												Borehole backfilled on date drilled unless otherwise noted.
	155											Consistency/Relative Density based on correction factor for Automatic hammer.

SAMPLE TYPE  Split Spoon

**N-VALUE** STANDARD PENETRATION RESISTANCE (AASHTO T-206)

**REC** RECOVERY

**LL:** LIQUID LIMIT **M:** NATURAL MOISTURE CONTENT

**% MOISTURE** PERCENT NATURAL MOISTURE CONTENT

**RQD** ROCK QUALITY DESIGNATION **PL:** PLASTIC LIMIT **F:** PERCENT PASSING NO. 200 SIEVE

GROUNDWATER LEVEL IN THE BOREHOLE AT TIME OF DRILLING

**UD** UNDISTURBED

**PI:** PLASTICITY INDEX

STABILIZED GROUNDWATER LEVEL

**Qu** POCKET PENETROMETER UNCONFINED COMPRESSIVE STRENGTH

PROJECT NAME: PWC Annexation - Phase V, Area 25  
PROJECT NUMBER: RD190493  
DRILLING METHOD: Hollow Stem Auger  
EQUIPMENT USED: GeoProbe 7822DT  
HAMMER TYPE: Automatic  
BORING LOCATION: See Boring Location Map (South)

LOCATION: Fayetteville, NC  
DATE DRILLED: 10/25/19  
WEATHER: 70's, Partly Sunny  
ELEVATION: 190  
DRILL CREW: Quantex  
LOGGED BY: M.Lumpkin

DEPTH (ft)	ELEVATION (ft)	SAMPLE TYPE	SAMPLE NO.	BLOWS PER INCREMENT	LAB DATA		SOIL DESCRIPTION	GRAPHIC	REMARKS
					N-Value	Qu (tsf)			
190							0.8 TOPSOIL: 9 inches		
	189.3		1	1					
			2	1		Sample 2 M: 7.8%	SILTY SAND (SM): very loose, light brown, fine to medium grained, moist		
			3	2		Sample 3 LL: 57 PL: 29 PI: 28 M: 17.3% F: 36%	CLAYEY SAND (SC): loose, brown, fine to medium grained, moist		
185			4	3		Sample 4 M: 18.1%			
			5	4		Sample 5 LL: 21 PL: 17 PI: 4 M: 9.9% F: 21%	SILTY CLAYEY SAND (SC-SM): medium dense, brown, fine to medium grained, moist		
180				5			10.0 (COASTAL PLAIN)		
							Boring Terminated at 10 feet.		
175									
170									Groundwater not encountered at time of drilling.
									Borehole backfilled on date drilled unless otherwise noted.
									Consistency/Relative Density based on correction factor for Automatic hammer.

SAMPLE TYPE  Split Spoon

**N-VALUE** STANDARD PENETRATION RESISTANCE (AASHTO T-206)

**REC** RECOVERY

**LL:** LIQUID LIMIT **M:** NATURAL MOISTURE CONTENT

**% MOISTURE** PERCENT NATURAL MOISTURE CONTENT

**RQD** ROCK QUALITY DESIGNATION **PL:** PLASTIC LIMIT **F:** PERCENT PASSING NO. 200 SIEVE

GROUNDWATER LEVEL IN THE BOREHOLE AT TIME OF DRILLING

**UD** UNDISTURBED

**PI:** PLASTICITY INDEX

STABILIZED GROUNDWATER LEVEL

**Qu** POCKET PENETROMETER UNCONFINED COMPRESSIVE STRENGTH





PROJECT NAME: PWC Annexation - Phase V, Area 25  
PROJECT NUMBER: RD190493  
DRILLING METHOD: Hollow Stem Auger  
EQUIPMENT USED: GeoProbe 7822DT  
HAMMER TYPE: Automatic  
BORING LOCATION: See Boring Location Map (South)

LOCATION: Fayetteville, NC  
DATE DRILLED: 10/24/19  
WEATHER: 70's, Sunny  
ELEVATION: 207  
DRILL CREW: Quantex  
LOGGED BY: M.Lumpkin

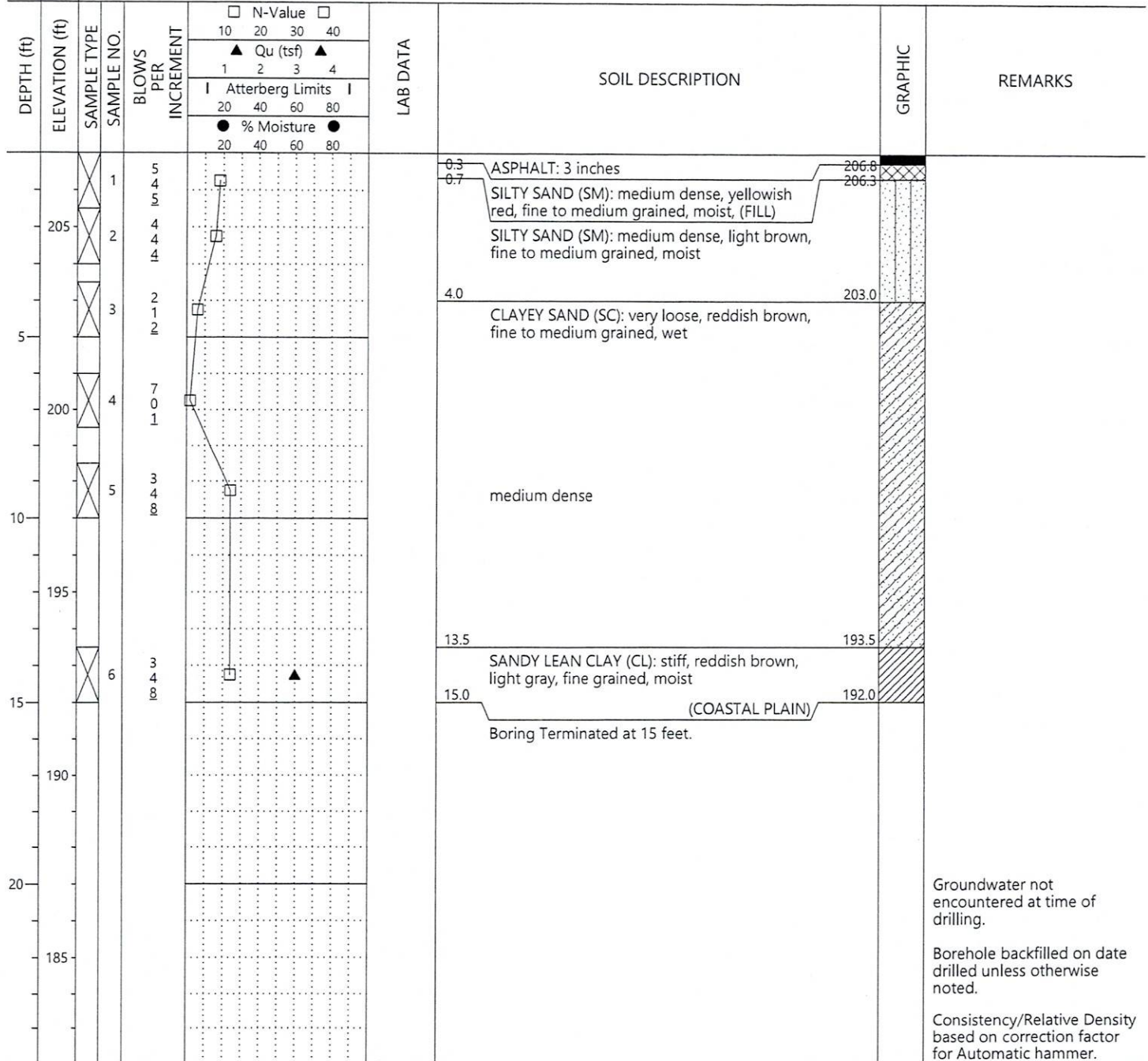

SAMPLE TYPE  Split Spoon

**N-VALUE** STANDARD PENETRATION RESISTANCE (AASHTO T-206)      **REC** RECOVERY      **LL:** LIQUID LIMIT      **M:** NATURAL MOISTURE CONTENT  
**% MOISTURE** PERCENT NATURAL MOISTURE CONTENT      **RQD** ROCK QUALITY DESIGNATION      **PL:** PLASTIC LIMIT      **F:** PERCENT PASSING NO. 200 SIEVE  
 GROUNDWATER LEVEL IN THE BOREHOLE AT TIME OF DRILLING      **UD** UNDISTURBED      **PI:** PLASTICITY INDEX  
 STABILIZED GROUNDWATER LEVEL      **Qu** POCKET PENETROMETER UNCONFINED COMPRESSIVE STRENGTH

PROJECT NAME: PWC Annexation - Phase V, Area 25  
 PROJECT NUMBER: RD190493  
 DRILLING METHOD: Hand Auger (due to trees in vicinity)  
 EQUIPMENT USED: Dynamic Cone Penetrometer  
 HAMMER TYPE: Manual  
 BORING LOCATION: See Boring Location Map (South)

LOCATION: Fayetteville, NC  
 DATE DRILLED: 10/28/19  
 WEATHER: 70's, Sunny  
 ELEVATION: 185  
 DRILL CREW: Building & Earth  
 LOGGED BY: M.Lumpkin

DEPTH (ft)	ELEVATION (ft)	SAMPLE TYPE	SAMPLE NO.	DCP TO N-VALUE CORRECTION	LAB DATA	SOIL DESCRIPTION	GRAPHIC	REMARKS																
	185				<table border="1" style="font-size: small; width: 100%;"> <tr> <td>□ N-Value</td> <td>□</td> </tr> <tr> <td>10 20 30 40</td> <td></td> </tr> <tr> <td>▲ Qu (tsf)</td> <td>▲</td> </tr> <tr> <td>1 2 3 4</td> <td></td> </tr> <tr> <td>  Atterberg Limits  </td> <td></td> </tr> <tr> <td>20 40 60 80</td> <td></td> </tr> <tr> <td>● % Moisture</td> <td>●</td> </tr> <tr> <td>20 40 60 80</td> <td></td> </tr> </table>	□ N-Value	□	10 20 30 40		▲ Qu (tsf)	▲	1 2 3 4		Atterberg Limits		20 40 60 80		● % Moisture	●	20 40 60 80				
□ N-Value	□																							
10 20 30 40																								
▲ Qu (tsf)	▲																							
1 2 3 4																								
Atterberg Limits																								
20 40 60 80																								
● % Moisture	●																							
20 40 60 80																								
			1	3		1.0 TOPSOIL: 12 inches	184.0																	
			2	1		CLAYEY SAND (SC): very loose, brown, fine to medium grained, moist																		
			3	5		loose																		
			4	15		medium dense																		
			5	15		4.0 SILTY CLAYEY SAND (SC-SM): medium dense, reddish brown, fine to medium grained, moist	181.0																	
5	180		6	15																				
			7	15																				
			8	13																				
			9	15	●	Sample 8 M: 8.9%																		
			10	15	●	Sample 10 LL: 23 PL: 19 PI: 4 M: 15.7% F: 19.8%																		
10	175			15		10.0 (COASTAL PLAIN)	175.0	Boring Terminated at 10 feet.																
								Groundwater not encountered at time of drilling.																
								Borehole backfilled on date drilled unless otherwise noted.																
								Consistency/Relative Density based on correction factor for DCP.																

SAMPLE TYPE DCP Cone Penetration

<b>N-VALUE</b> STANDARD PENETRATION RESISTANCE (AASHTO T-206)	<b>REC</b> RECOVERY	<b>LL:</b> LIQUID LIMIT <b>M:</b> NATURAL MOISTURE CONTENT
<b>% MOISTURE</b> PERCENT NATURAL MOISTURE CONTENT	<b>RQD</b> ROCK QUALITY DESIGNATION	<b>PL:</b> PLASTIC LIMIT <b>F:</b> PERCENT PASSING NO. 200 SIEVE
GROUNDWATER LEVEL IN THE BOREHOLE AT TIME OF DRILLING	<b>UD</b> UNDISTURBED	<b>PI:</b> PLASTICITY INDEX
STABILIZED GROUNDWATER LEVEL	<b>Qu</b> POCKET PENETROMETER UNCONFINED COMPRESSIVE STRENGTH	

PROJECT NAME: PWC Annexation - Phase V, Area 25  
PROJECT NUMBER: RD190493  
DRILLING METHOD: Hollow Stem Auger  
EQUIPMENT USED: GeoProbe 7822DT  
HAMMER TYPE: Automatic  
BORING LOCATION: See Boring Location Map (South)

LOCATION: Fayetteville, NC  
DATE DRILLED: 10/24/19  
WEATHER: 70's, Sunny  
ELEVATION: 206  
DRILL CREW: Quantex  
LOGGED BY: M.Lumpkin

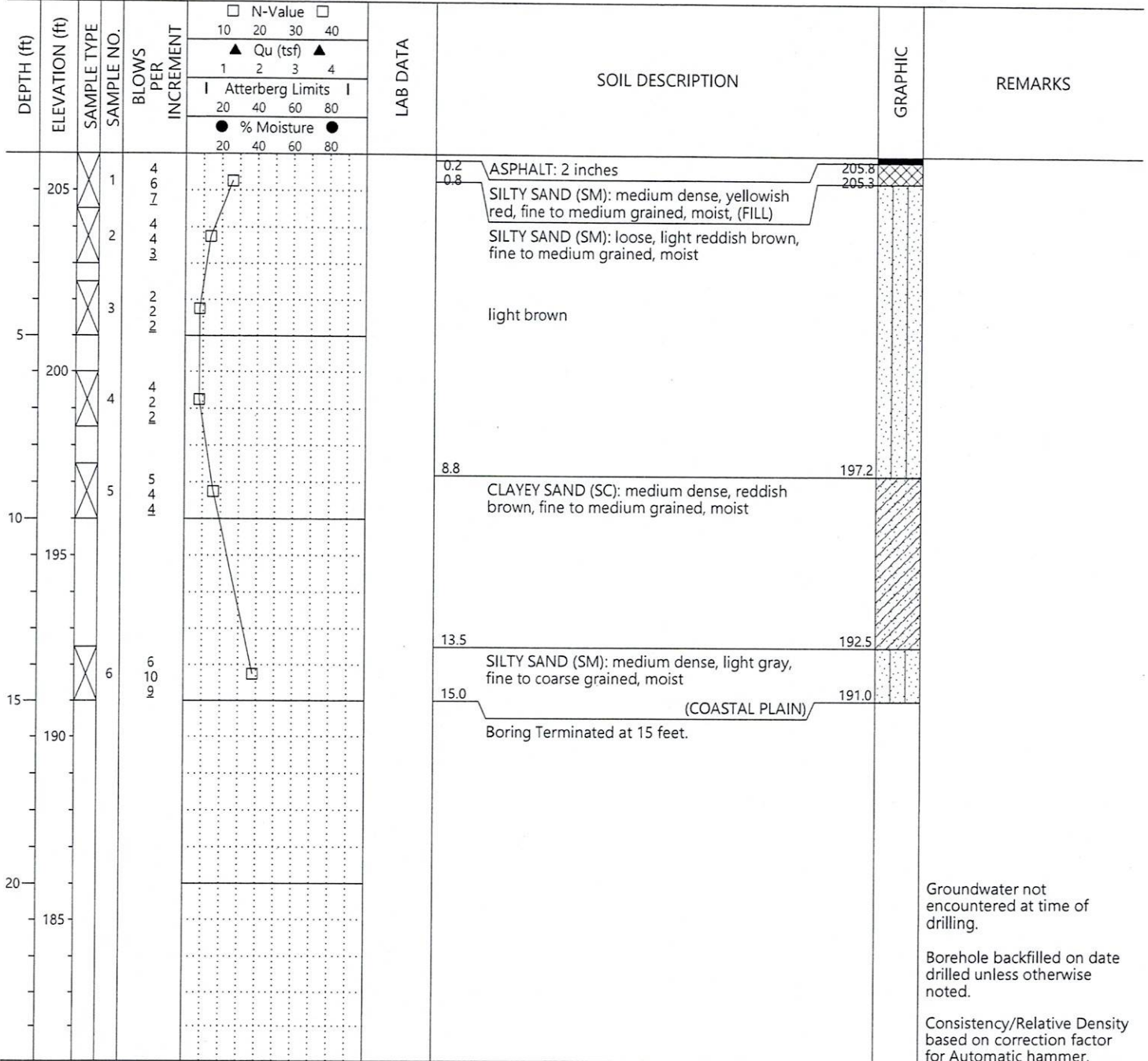

SAMPLE TYPE  Split Spoon

**N-VALUE** STANDARD PENETRATION RESISTANCE (AASHTO T-206)

**REC** RECOVERY

**LL:** LIQUID LIMIT **M:** NATURAL MOISTURE CONTENT

**% MOISTURE** PERCENT NATURAL MOISTURE CONTENT

**RQD** ROCK QUALITY DESIGNATION **PL:** PLASTIC LIMIT **F:** PERCENT PASSING NO. 200 SIEVE

GROUNDWATER LEVEL IN THE BOREHOLE AT TIME OF DRILLING

**UD** UNDISTURBED

**PI:** PLASTICITY INDEX

STABILIZED GROUNDWATER LEVEL

**Qu** POCKET PENETROMETER UNCONFINED COMPRESSIVE STRENGTH

PROJECT NAME: PWC Annexation - Phase V, Area 25  
PROJECT NUMBER: RD190493  
DRILLING METHOD: Hollow Stem Auger  
EQUIPMENT USED: GeoProbe 7822DT  
HAMMER TYPE: Automatic  
BORING LOCATION: See Boring Location Map (South)

LOCATION: Fayetteville, NC  
DATE DRILLED: 10/24/19  
WEATHER: 70's, Sunny  
ELEVATION: 190  
DRILL CREW: Quantex  
LOGGED BY: M.Lumpkin

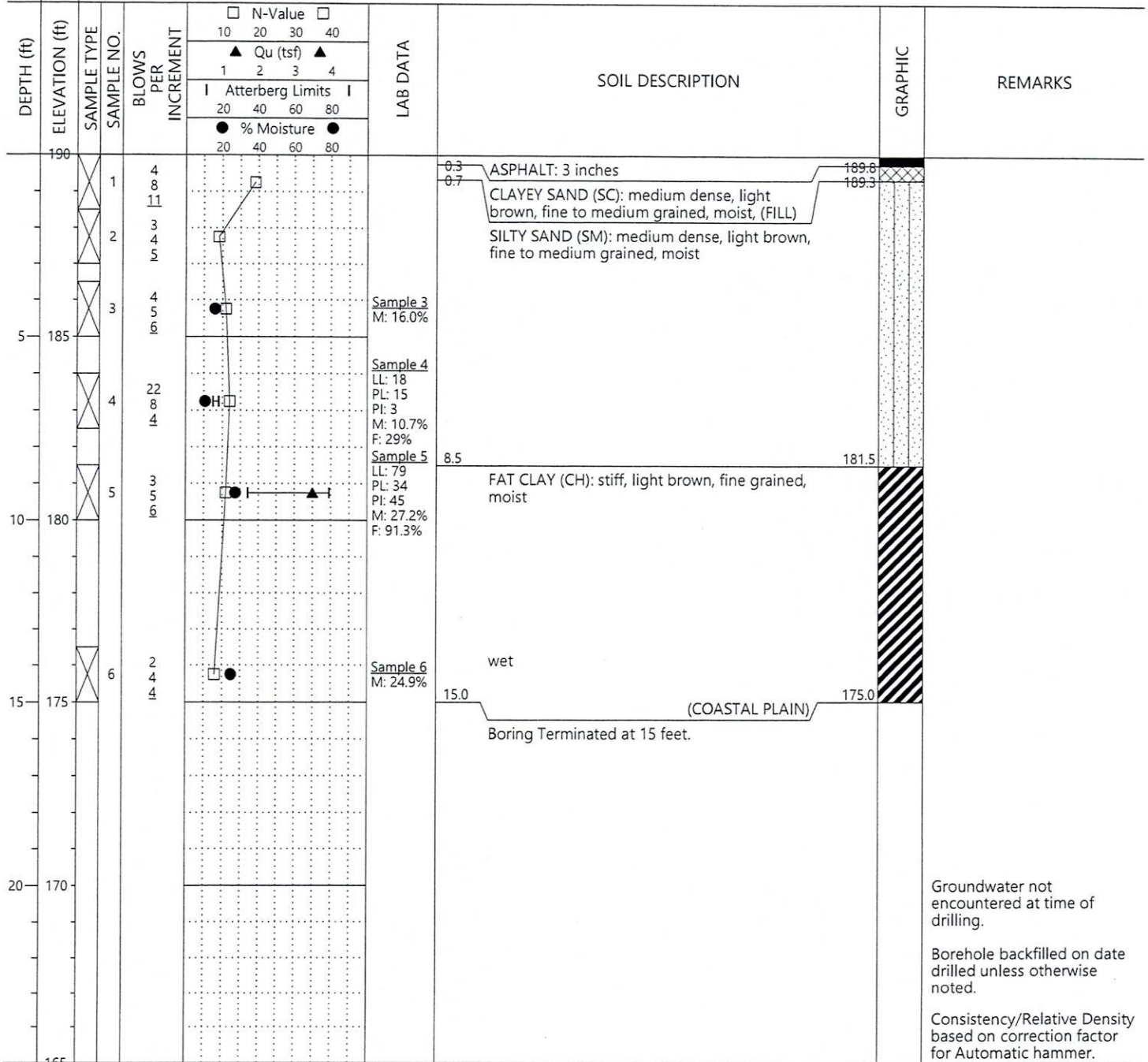

SAMPLE TYPE  Split Spoon

**N-VALUE** STANDARD PENETRATION RESISTANCE (AASHTO T-206)

**% MOISTURE** PERCENT NATURAL MOISTURE CONTENT

GROUNDWATER LEVEL IN THE BOREHOLE AT TIME OF DRILLING

STABILIZED GROUNDWATER LEVEL

**REC** RECOVERY

**RQD** ROCK QUALITY DESIGNATION

**UD** UNDISTURBED

**Qu**

**LL:** LIQUID LIMIT **M:** NATURAL MOISTURE CONTENT

**PL:** PLASTIC LIMIT **F:** PERCENT PASSING NO. 200 SIEVE

**PI:** PLASTICITY INDEX

**Qu** POCKET PENETROMETER UNCONFINED COMPRESSIVE STRENGTH

PROJECT NAME: PWC Annexation - Phase V, Area 25  
PROJECT NUMBER: RD190493  
DRILLING METHOD: Hollow Stem Auger  
EQUIPMENT USED: GeoProbe 7822DT  
HAMMER TYPE: Automatic  
BORING LOCATION: See Boring Location Map (South)

LOCATION: Fayetteville, NC  
DATE DRILLED: 10/24/19  
WEATHER: 70's, Sunny  
ELEVATION: 210  
DRILL CREW: Quantex  
LOGGED BY: M.Lumpkin

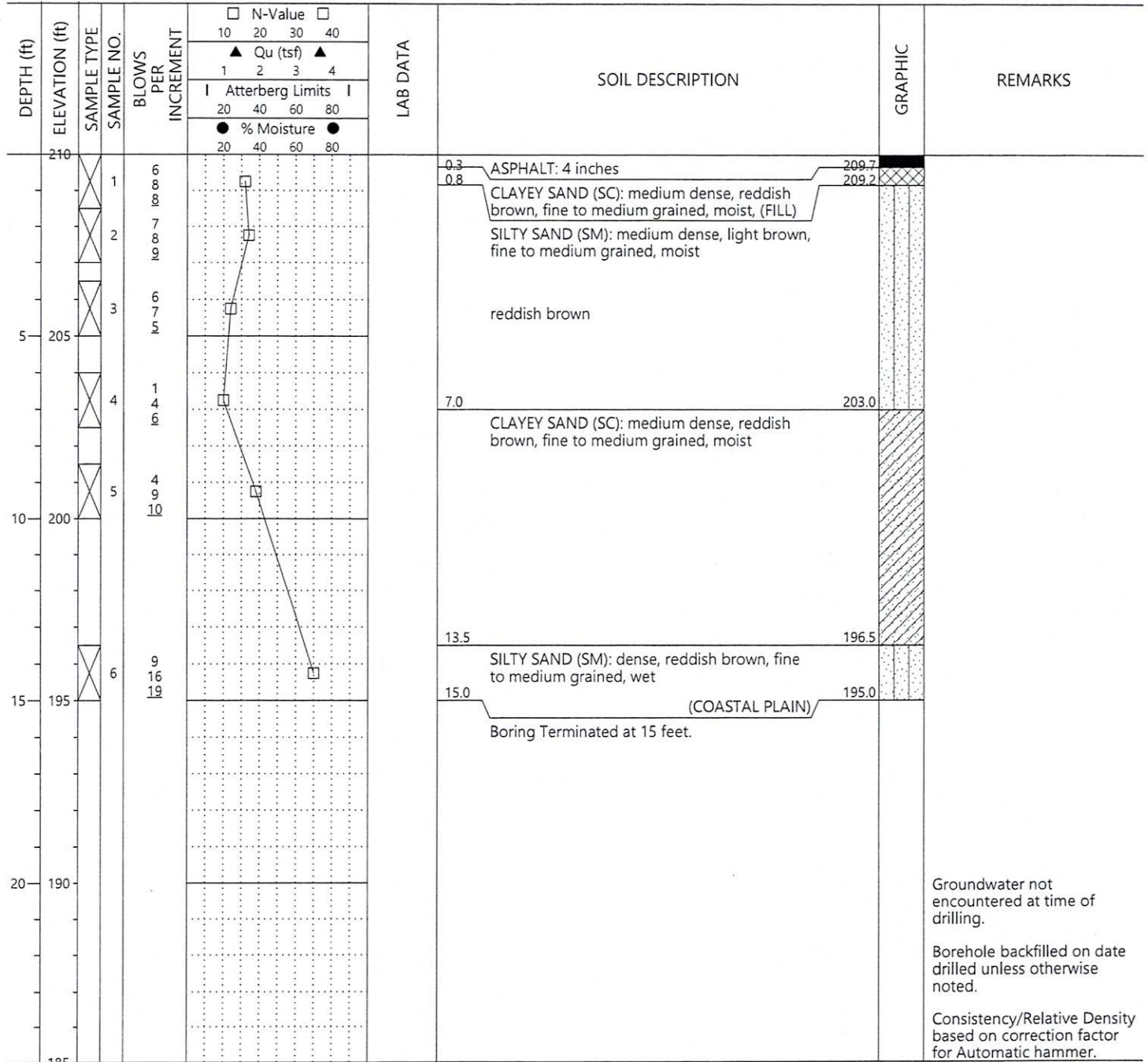

SAMPLE TYPE  Split Spoon

**N-VALUE** STANDARD PENETRATION RESISTANCE (AASHTO T-206)

**REC** RECOVERY

**LL:** LIQUID LIMIT **M:** NATURAL MOISTURE CONTENT

**% MOISTURE** PERCENT NATURAL MOISTURE CONTENT

**RQD** ROCK QUALITY DESIGNATION **PL:** PLASTIC LIMIT **F:** PERCENT PASSING NO. 200 SIEVE

GROUNDWATER LEVEL IN THE BOREHOLE AT TIME OF DRILLING **UD** UNDISTURBED

**PI:** PLASTICITY INDEX

STABILIZED GROUNDWATER LEVEL

**Qu** POCKET PENETROMETER UNCONFINED COMPRESSIVE STRENGTH

PROJECT NAME: PWC Annexation - Phase V, Area 25  
PROJECT NUMBER: RD190493  
DRILLING METHOD: Hollow Stem Auger  
EQUIPMENT USED: GeoProbe 7822DT  
HAMMER TYPE: Automatic  
BORING LOCATION: See Boring Location Map (South)

LOCATION: Fayetteville, NC  
DATE DRILLED: 10/24/19  
WEATHER: 70's, Sunny  
ELEVATION: 212  
DRILL CREW: Quantex  
LOGGED BY: M.Lumpkin

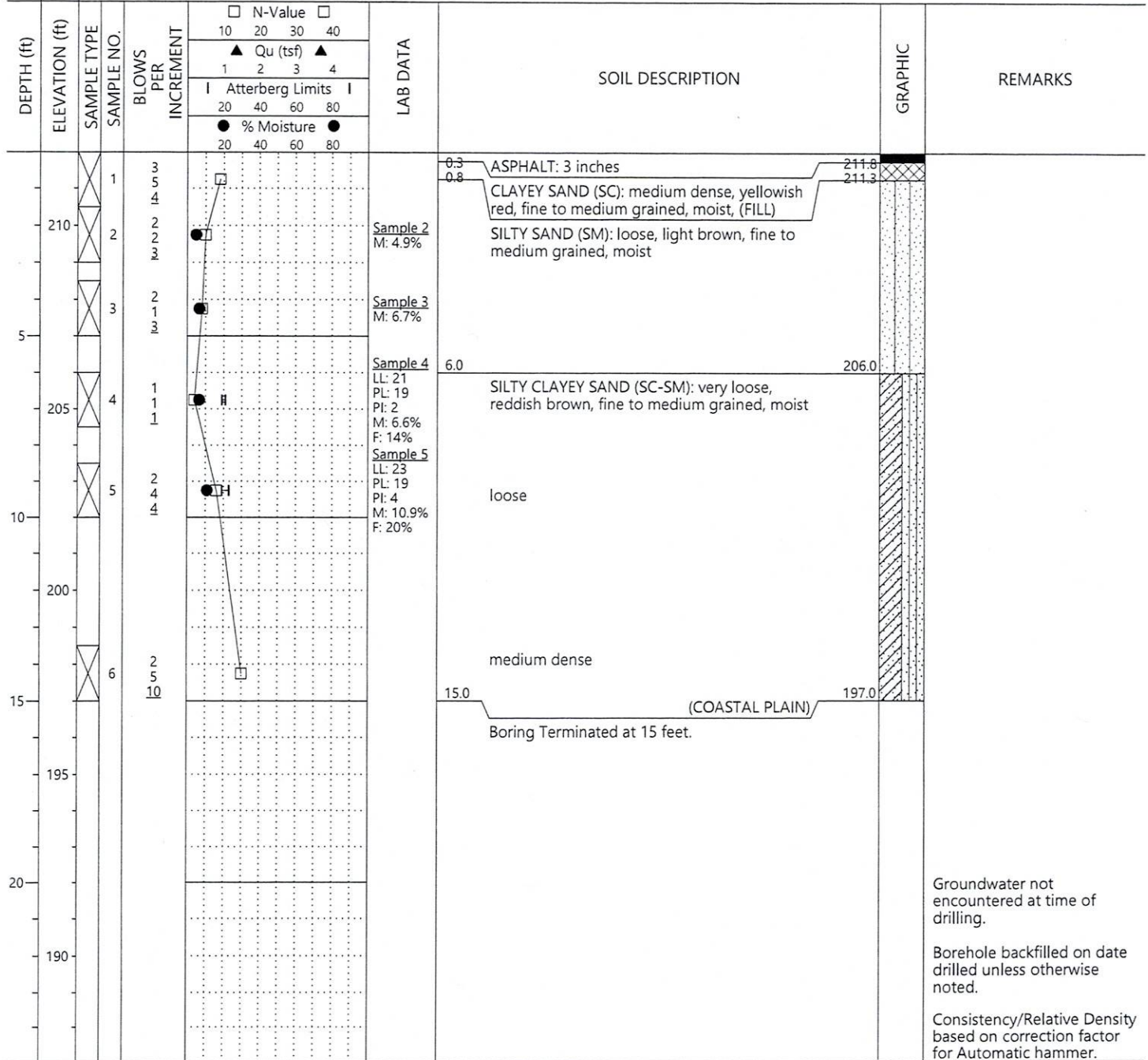

SAMPLE TYPE  Split Spoon

**N-VALUE** STANDARD PENETRATION RESISTANCE (AASHTO T-206)      **REC** RECOVERY      **LL:** LIQUID LIMIT      **M:** NATURAL MOISTURE CONTENT  
**% MOISTURE** PERCENT NATURAL MOISTURE CONTENT      **RQD** ROCK QUALITY DESIGNATION      **PL:** PLASTIC LIMIT      **F:** PERCENT PASSING NO. 200 SIEVE  
 GROUNDWATER LEVEL IN THE BOREHOLE AT TIME OF DRILLING      **UD** UNDISTURBED      **PI:** PLASTICITY INDEX  
 STABILIZED GROUNDWATER LEVEL      **Qu** POCKET PENETROMETER UNCONFINED COMPRESSIVE STRENGTH



Geotechnical, Environmental, and Materials Engineers

# LOG OF BORING

Designation: SB-12

Sheet 1 of 1

610 Spring Branch Road

Dunn, NC 28334

Office: (910) 292-2085

PROJECT NAME: PWC Annexation - Phase V, Area 25  
 PROJECT NUMBER: RD190493  
 DRILLING METHOD: Hollow Stem Auger  
 EQUIPMENT USED: GeoProbe 7822DT  
 HAMMER TYPE: Automatic  
 BORING LOCATION: See Boring Location Map (South)

LOCATION: Fayetteville, NC  
 DATE DRILLED: 10/24/19  
 WEATHER: 70's, Sunny  
 ELEVATION: 217  
 DRILL CREW: Quantex  
 LOGGED BY: M.Lumpkin

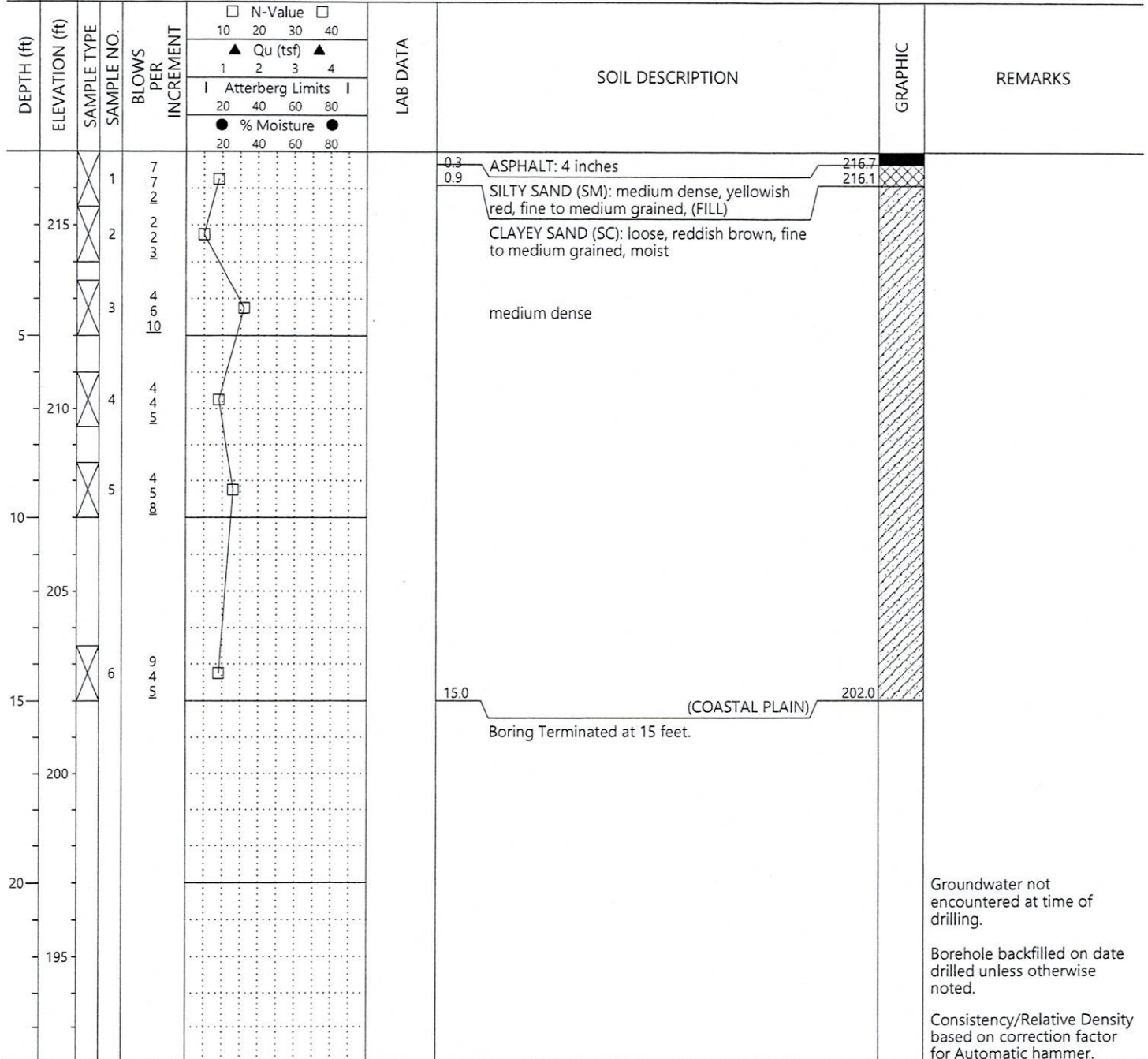

SAMPLE TYPE  Split Spoon

**N-VALUE** STANDARD PENETRATION RESISTANCE (AASHTO T-206)      **REC** RECOVERY      **LL:** LIQUID LIMIT      **M:** NATURAL MOISTURE CONTENT  
**% MOISTURE** PERCENT NATURAL MOISTURE CONTENT      **RQD** ROCK QUALITY DESIGNATION      **PL:** PLASTIC LIMIT      **F:** PERCENT PASSING NO. 200 SIEVE  
 GROUNDWATER LEVEL IN THE BOREHOLE AT TIME OF DRILLING      **UD** UNDISTURBED      **PI:** PLASTICITY INDEX  
 STABILIZED GROUNDWATER LEVEL      **Qu** POCKET PENETROMETER UNCONFINED COMPRESSIVE STRENGTH

PROJECT NAME: PWC Annexation - Phase V, Area 25  
 PROJECT NUMBER: RD190493  
 DRILLING METHOD: Hollow Stem Auger  
 EQUIPMENT USED: GeoProbe 7822DT  
 HAMMER TYPE: Automatic  
 BORING LOCATION: See Boring Location Map (South)

LOCATION: Fayetteville, NC  
 DATE DRILLED: 10/24/19  
 WEATHER: 70's, Sunny  
 ELEVATION: 217  
 DRILL CREW: Quantex  
 LOGGED BY: M.Lumpkin

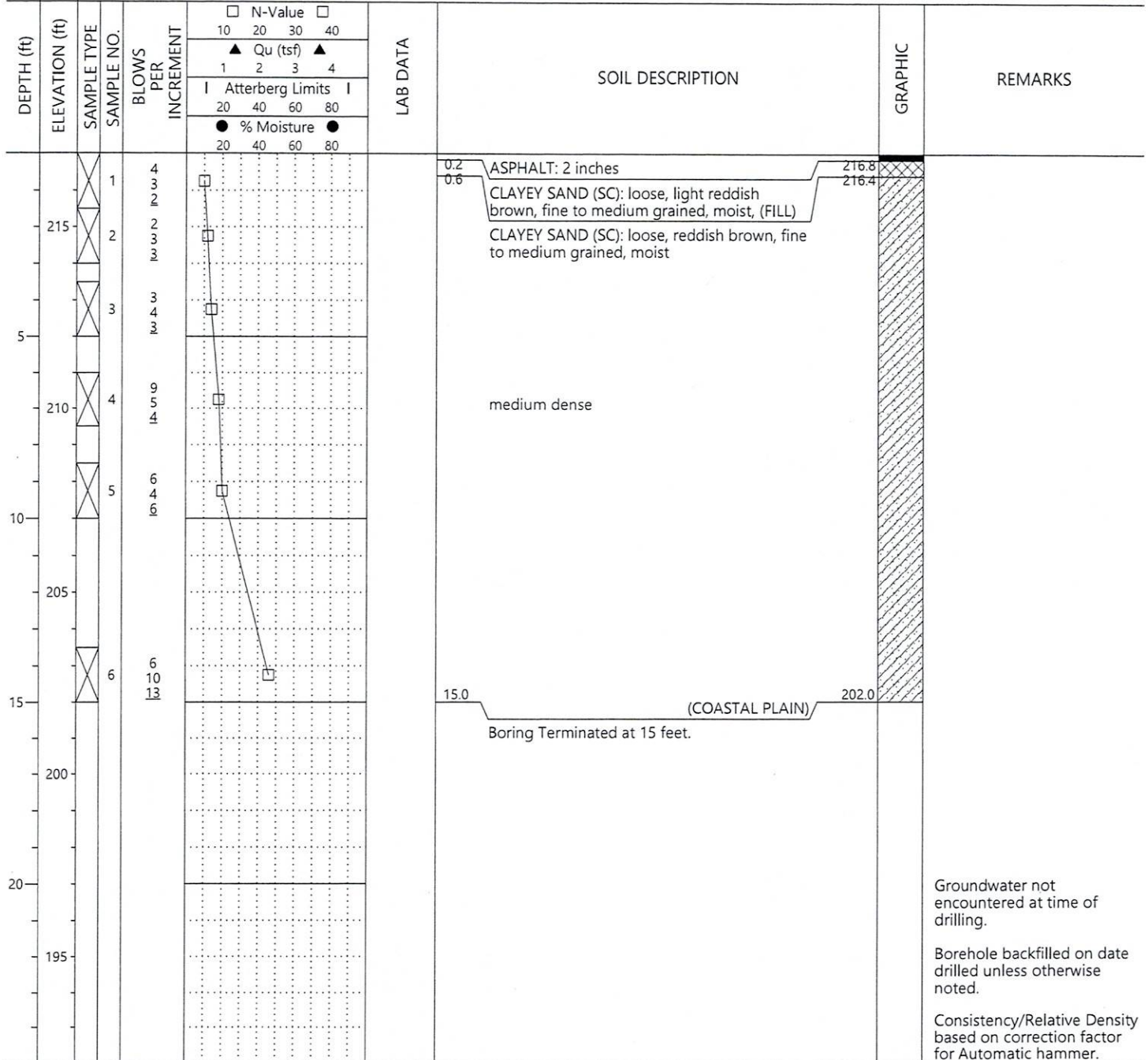

Groundwater not encountered at time of drilling.  
 Borehole backfilled on date drilled unless otherwise noted.  
 Consistency/Relative Density based on correction factor for Automatic hammer.

SAMPLE TYPE  Split Spoon

**N-VALUE** STANDARD PENETRATION RESISTANCE (AASHTO T-206)      **REC** RECOVERY      **LL:** LIQUID LIMIT      **M:** NATURAL MOISTURE CONTENT  
**% MOISTURE** PERCENT NATURAL MOISTURE CONTENT      **RQD** ROCK QUALITY DESIGNATION      **PL:** PLASTIC LIMIT      **F:** PERCENT PASSING NO. 200 SIEVE  
 GROUNDWATER LEVEL IN THE BOREHOLE AT TIME OF DRILLING      **UD** UNDISTURBED      **PI:** PLASTICITY INDEX  
 STABILIZED GROUNDWATER LEVEL      **Qu** POCKET PENETROMETER UNCONFINED COMPRESSIVE STRENGTH



PROJECT NAME: PWC Annexation - Phase V, Area 25  
PROJECT NUMBER: RD190493  
DRILLING METHOD: Hollow Stem Auger  
EQUIPMENT USED: GeoProbe 7822DT  
HAMMER TYPE: Automatic  
BORING LOCATION: See Boring Location Map (South)

LOCATION: Fayetteville, NC  
DATE DRILLED: 10/24/19  
WEATHER: 70's, Sunny  
ELEVATION: 222  
DRILL CREW: Quantex  
LOGGED BY: M.Lumpkin

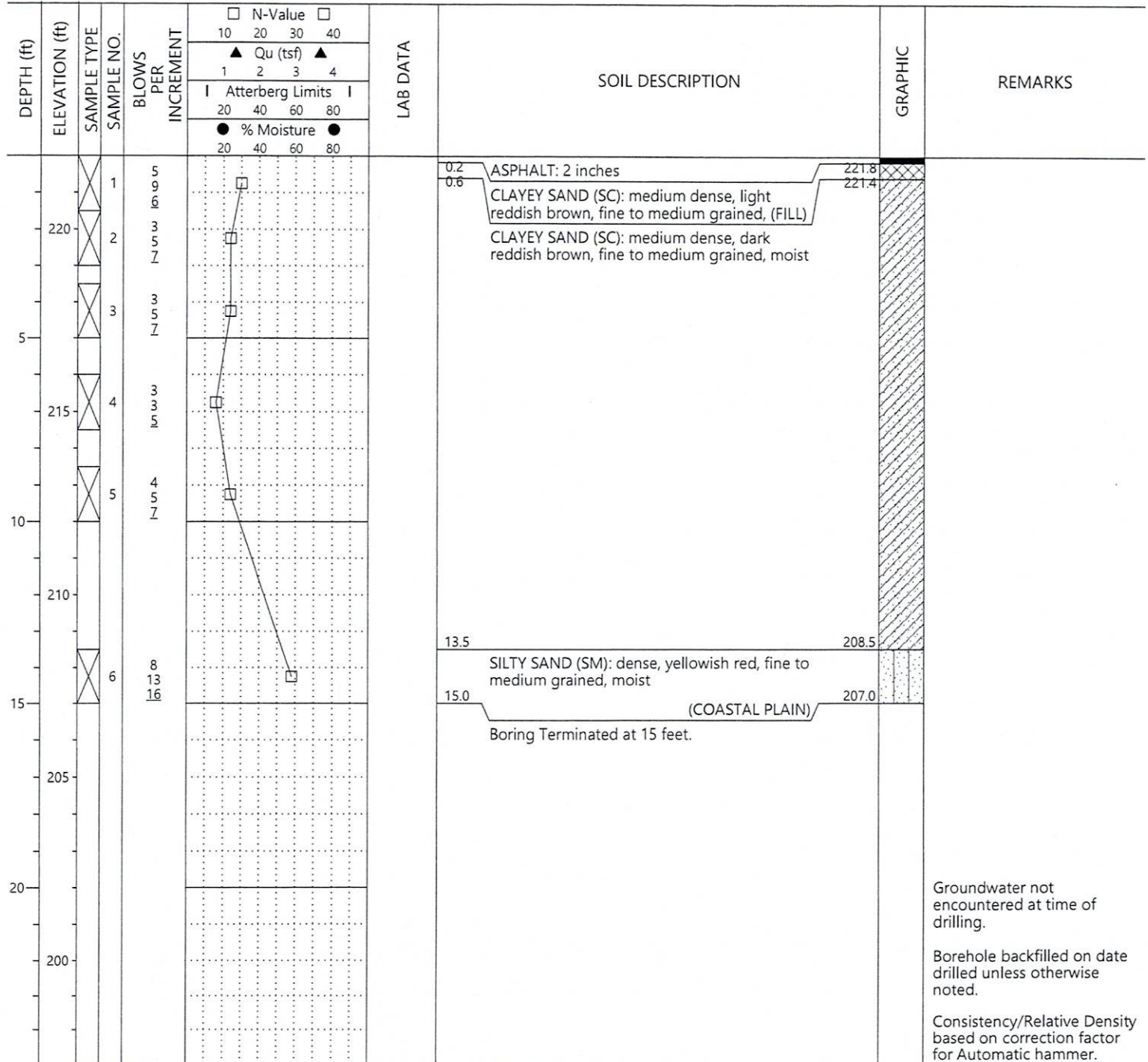

SAMPLE TYPE  Split Spoon

**N-VALUE** STANDARD PENETRATION RESISTANCE (AASHTO T-206)      **REC** RECOVERY      **LL:** LIQUID LIMIT      **M:** NATURAL MOISTURE CONTENT  
**% MOISTURE** PERCENT NATURAL MOISTURE CONTENT      **RQD** ROCK QUALITY DESIGNATION      **PL:** PLASTIC LIMIT      **F:** PERCENT PASSING NO. 200 SIEVE  
 GROUNDWATER LEVEL IN THE BOREHOLE AT TIME OF DRILLING      **UD** UNDISTURBED      **PI:** PLASTICITY INDEX  
 STABILIZED GROUNDWATER LEVEL      **Qu** POCKET PENETROMETER UNCONFINED COMPRESSIVE STRENGTH



Geotechnical, Environmental, and Materials Engineers

# LOG OF BORING

Designation: SB-15

Sheet 1 of 1

610 Spring Branch Road

Dunn, NC 28334

Office: (910) 292-2085

PROJECT NAME: PWC Annexation - Phase V, Area 25  
 PROJECT NUMBER: RD190493  
 DRILLING METHOD: Hollow Stem Auger  
 EQUIPMENT USED: GeoProbe 7822DT  
 HAMMER TYPE: Automatic  
 BORING LOCATION: See Boring Location Map (North)

LOCATION: Fayetteville, NC  
 DATE DRILLED: 10/23/19  
 WEATHER: 60's, Sunny  
 ELEVATION: 214  
 DRILL CREW: Quantex  
 LOGGED BY: M.Lumpkin

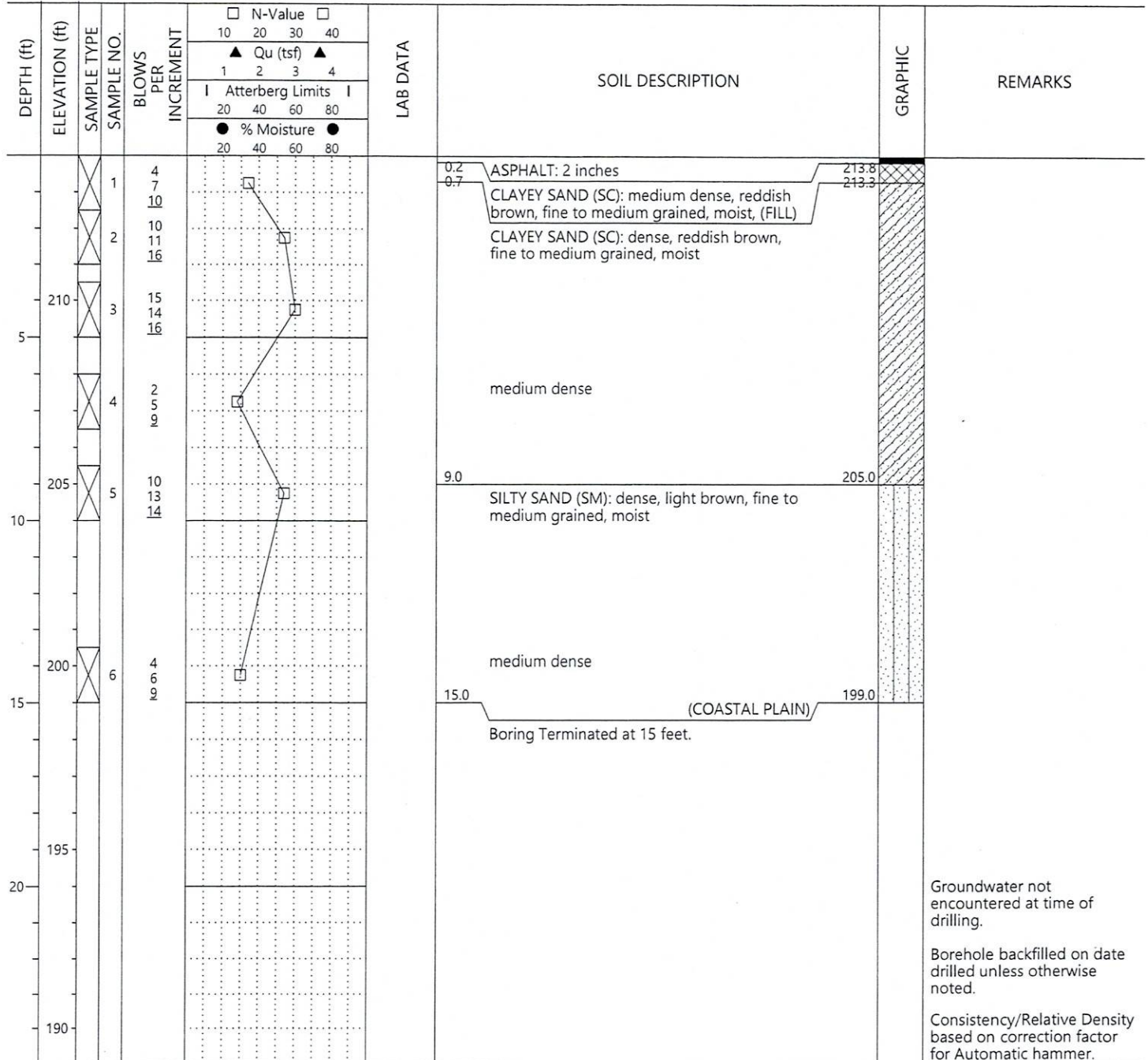

SAMPLE TYPE  Split Spoon

**N-VALUE** STANDARD PENETRATION RESISTANCE (AASHTO T-206)      **REC** RECOVERY      **LL:** LIQUID LIMIT    **M:** NATURAL MOISTURE CONTENT  
**% MOISTURE** PERCENT NATURAL MOISTURE CONTENT      **RQD** ROCK QUALITY DESIGNATION    **PL:** PLASTIC LIMIT    **F:** PERCENT PASSING NO. 200 SIEVE  
 GROUNDWATER LEVEL IN THE BOREHOLE AT TIME OF DRILLING    **UD** UNDISTURBED      **PI:** PLASTICITY INDEX  
 STABILIZED GROUNDWATER LEVEL      **Qu** POCKET PENETROMETER UNCONFINED COMPRESSIVE STRENGTH

PROJECT NAME: PWC Annexation - Phase V, Area 25  
PROJECT NUMBER: RD190493  
DRILLING METHOD: Hollow Stem Auger  
EQUIPMENT USED: GeoProbe 7822DT  
HAMMER TYPE: Automatic  
BORING LOCATION: See Boring Location Map (North)

LOCATION: Fayetteville, NC  
DATE DRILLED: 10/23/19  
WEATHER: 60's, Sunny  
ELEVATION: 224  
DRILL CREW: Quantex  
LOGGED BY: M.Lumpkin

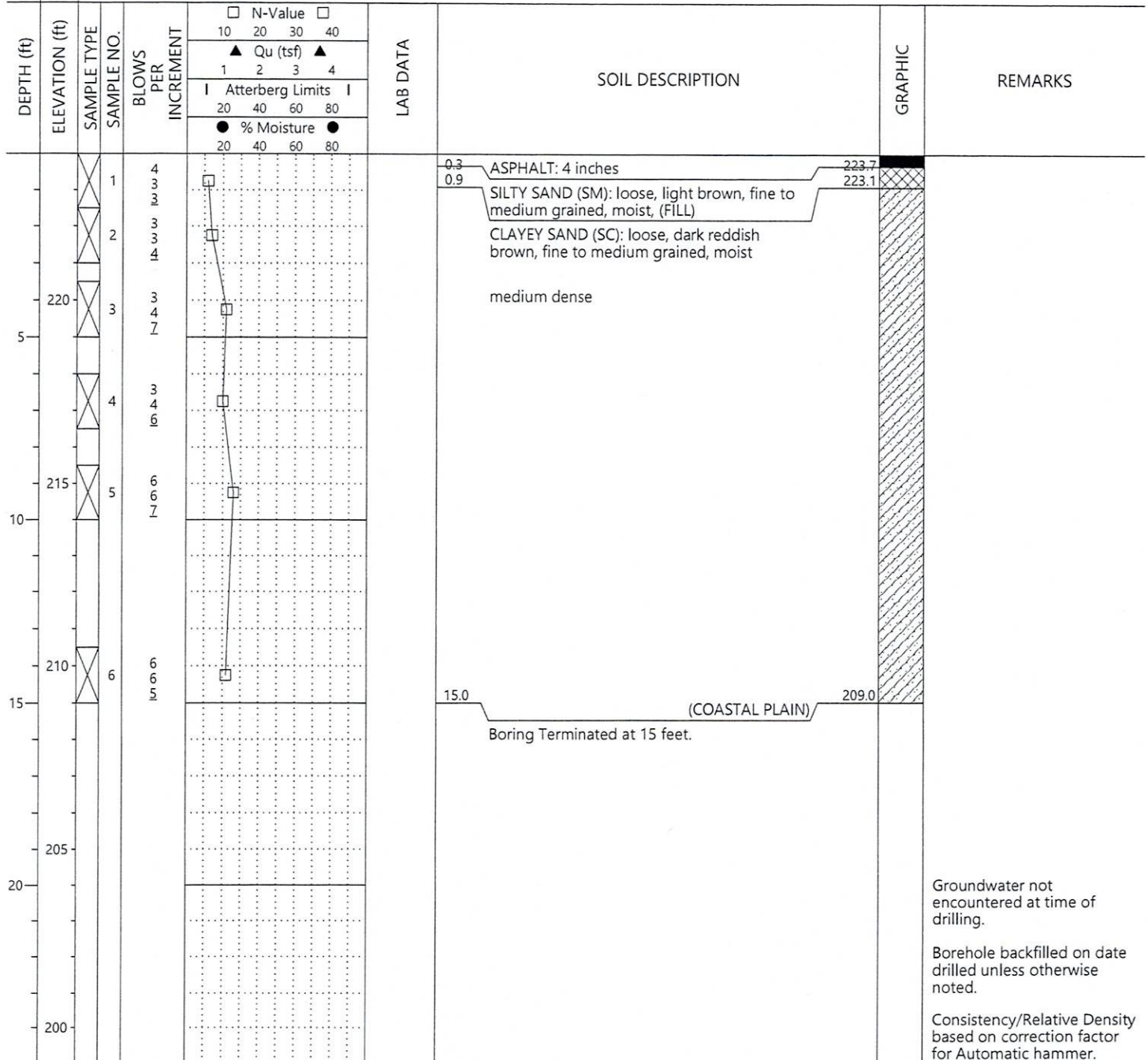

SAMPLE TYPE  Split Spoon

**N-VALUE** STANDARD PENETRATION RESISTANCE (AASHTO T-206)

**REC** RECOVERY

**LL:** LIQUID LIMIT **M:** NATURAL MOISTURE CONTENT

**% MOISTURE** PERCENT NATURAL MOISTURE CONTENT

**RQD** ROCK QUALITY DESIGNATION **PL:** PLASTIC LIMIT **F:** PERCENT PASSING NO. 200 SIEVE

GROUNDWATER LEVEL IN THE BOREHOLE AT TIME OF DRILLING

**UD** UNDISTURBED

**PI:** PLASTICITY INDEX

STABILIZED GROUNDWATER LEVEL

**Qu** POCKET PENETROMETER UNCONFINED COMPRESSIVE STRENGTH



Geotechnical, Environmental, and Materials Engineers

# LOG OF BORING

Designation: SB-17

Sheet 1 of 1

610 Spring Branch Road  
Dunn, NC 28334  
Office: (910) 292-2085

PROJECT NAME: PWC Annexation - Phase V, Area 25  
PROJECT NUMBER: RD190493  
DRILLING METHOD: Hollow Stem Auger  
EQUIPMENT USED: GeoProbe 7822DT  
HAMMER TYPE: Automatic  
BORING LOCATION: See Boring Location Map (South)

LOCATION: Fayetteville, NC  
DATE DRILLED: 10/25/19  
WEATHER: 70's, Partly Sunny  
ELEVATION: 196  
DRILL CREW: Quantex  
LOGGED BY: M.Lumpkin

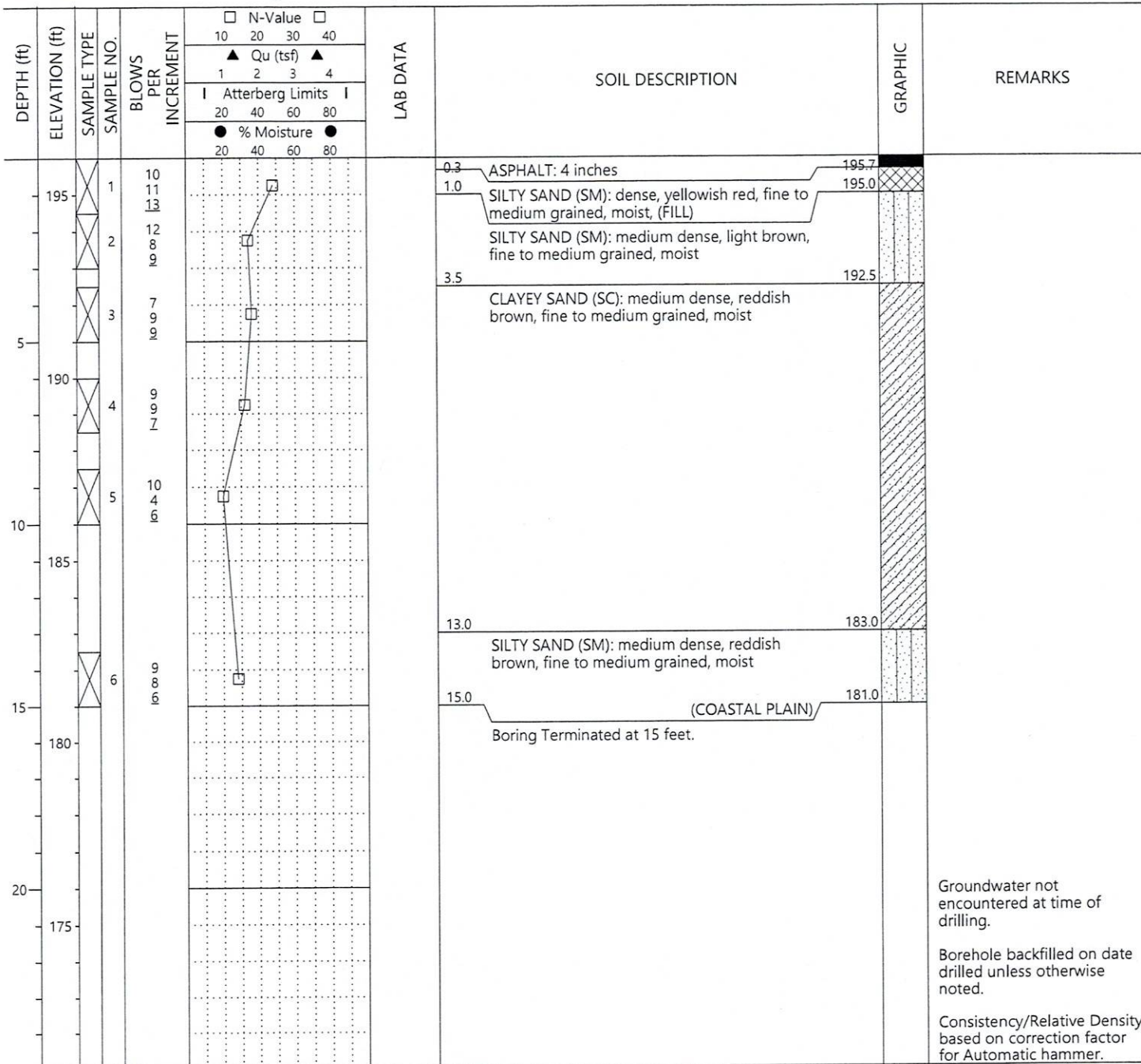

Groundwater not encountered at time of drilling.  
Borehole backfilled on date drilled unless otherwise noted.  
Consistency/Relative Density based on correction factor for Automatic hammer.

SAMPLE TYPE  Split Spoon

- N-VALUE** STANDARD PENETRATION RESISTANCE (AASHTO T-206)
- % MOISTURE** PERCENT NATURAL MOISTURE CONTENT
- GROUNDWATER LEVEL IN THE BOREHOLE AT TIME OF DRILLING
- STABILIZED GROUNDWATER LEVEL
- REC** RECOVERY
- RQD** ROCK QUALITY DESIGNATION
- UD** UNDISTURBED
- Qu** POCKET PENETROMETER UNCONFINED COMPRESSIVE STRENGTH
- LL:** LIQUID LIMIT **M:** NATURAL MOISTURE CONTENT
- PL:** PLASTIC LIMIT **F:** PERCENT PASSING NO. 200 SIEVE
- PI:** PLASTICITY INDEX



Geotechnical, Environmental, and Materials Engineers

# LOG OF BORING

Designation: SB-18

Sheet 1 of 1

610 Spring Branch Road  
Dunn, NC 28334  
Office: (910) 292-2085

PROJECT NAME: PWC Annexation - Phase V, Area 25  
PROJECT NUMBER: RD190493  
DRILLING METHOD: Hollow Stem Auger  
EQUIPMENT USED: GeoProbe 7822DT  
HAMMER TYPE: Automatic  
BORING LOCATION: See Boring Location Map (South)

LOCATION: Fayetteville, NC  
DATE DRILLED: 10/25/19  
WEATHER: 70's, Partly Sunny  
ELEVATION: 191  
DRILL CREW: Quantex  
LOGGED BY: M.Lumpkin

DEPTH (ft)	ELEVATION (ft)	SAMPLE TYPE	SAMPLE NO.	BLOWS PER INCREMENT	LAB DATA				SOIL DESCRIPTION	GRAPHIC	REMARKS	
					N-Value	Qu (tsf)	Atterberg Limits	% Moisture				
190	190.6		1	6	10	1	20	20	0.4	ASPHALT: 5 inches		
190	189.5		2	5	10	2	20	20	1.5	SILTY SAND (SM): medium dense, yellowish red, fine to medium grained, moist, (FILL) CLAYEY SAND (SC): medium dense, reddish brown, fine to medium grained, moist		
185			3	8	10	3	30	30				
180			4	28	10	4	40	40				
180			5	3	10	3	30	30	9.0	SILTY SAND (SM): loose, light brown, fine to medium grained, moist		
175			6	2	10	2	20	20	15.0	(COASTAL PLAIN) Boring Terminated at 15 feet.		

Groundwater not encountered at time of drilling.  
Borehole backfilled on date drilled unless otherwise noted.  
Consistency/Relative Density based on correction factor for Automatic hammer.

SAMPLE TYPE  Split Spoon

**N-VALUE** STANDARD PENETRATION RESISTANCE (AASHTO T-206)      **REC** RECOVERY      **LL:** LIQUID LIMIT    **M:** NATURAL MOISTURE CONTENT  
**% MOISTURE** PERCENT NATURAL MOISTURE CONTENT      **RQD** ROCK QUALITY DESIGNATION    **PL:** PLASTIC LIMIT    **F:** PERCENT PASSING NO. 200 SIEVE  
 GROUNDWATER LEVEL IN THE BOREHOLE AT TIME OF DRILLING    **UD** UNDISTURBED      **PI:** PLASTICITY INDEX  
 STABILIZED GROUNDWATER LEVEL      **Qu** POCKET PENETROMETER UNCONFINED COMPRESSIVE STRENGTH

PROJECT NAME: PWC Annexation - Phase V, Area 25  
PROJECT NUMBER: RD190493  
DRILLING METHOD: Hollow Stem Auger  
EQUIPMENT USED: GeoProbe 7822DT  
HAMMER TYPE: Automatic  
BORING LOCATION: See Boring Location Map (North)

LOCATION: Fayetteville, NC  
DATE DRILLED: 10/23/19  
WEATHER: 60's, Sunny  
ELEVATION: 223  
DRILL CREW: Quantex  
LOGGED BY: M.Lumpkin

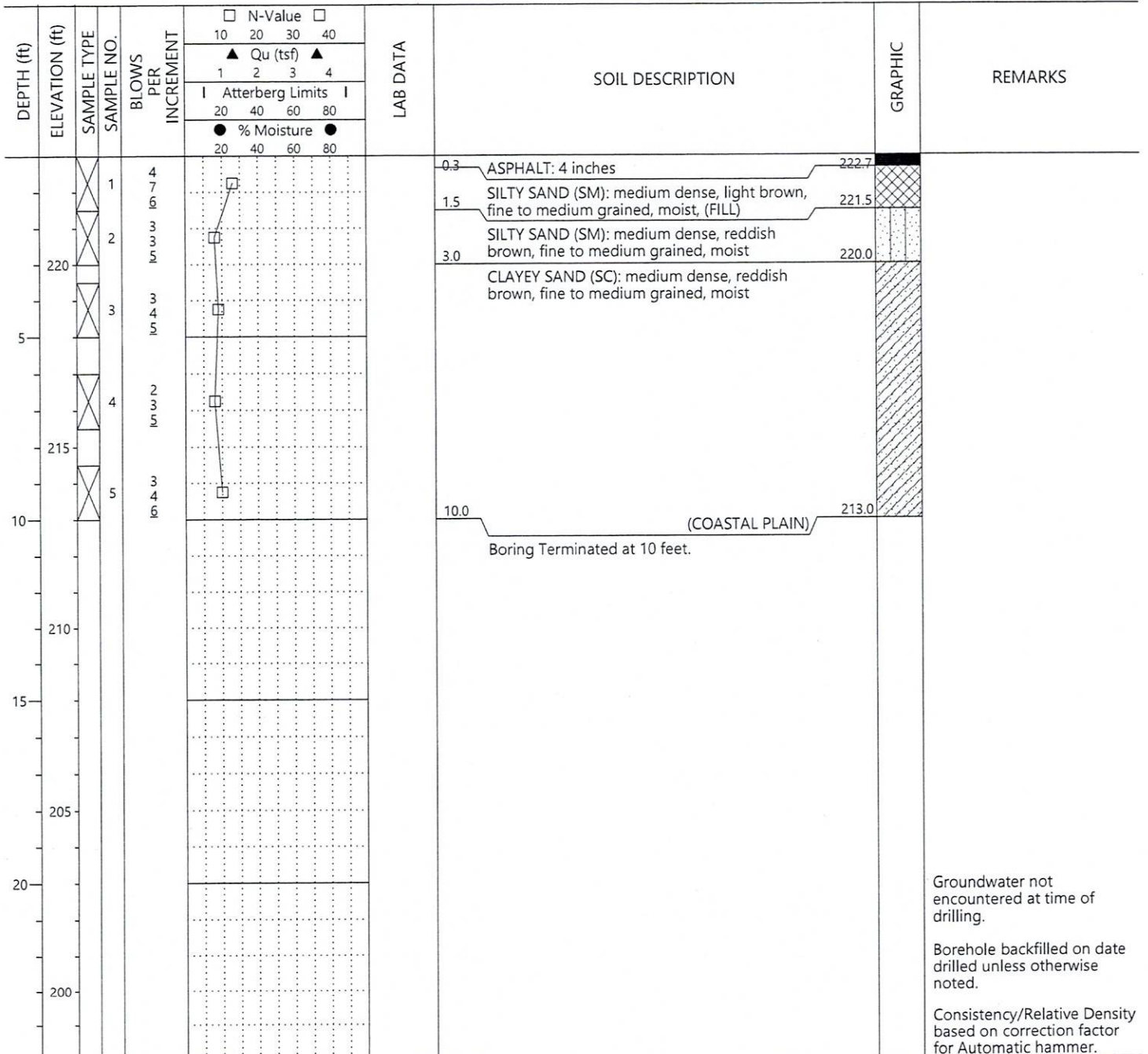

SAMPLE TYPE  Split Spoon

**N-VALUE** STANDARD PENETRATION RESISTANCE (AASHTO T-206)

**REC** RECOVERY

**LL:** LIQUID LIMIT **M:** NATURAL MOISTURE CONTENT

**% MOISTURE** PERCENT NATURAL MOISTURE CONTENT

**RQD** ROCK QUALITY DESIGNATION **PL:** PLASTIC LIMIT **F:** PERCENT PASSING NO. 200 SIEVE

GROUNDWATER LEVEL IN THE BOREHOLE AT TIME OF DRILLING

**UD** UNDISTURBED

**PI:** PLASTICITY INDEX

STABILIZED GROUNDWATER LEVEL

**Qu** POCKET PENETROMETER UNCONFINED COMPRESSIVE STRENGTH

PROJECT NAME: PWC Annexation - Phase V, Area 25  
 PROJECT NUMBER: RD190493  
 DRILLING METHOD: Hollow Stem Auger  
 EQUIPMENT USED: GeoProbe 7822DT  
 HAMMER TYPE: Automatic  
 BORING LOCATION: See Boring Location Map (North)

LOCATION: Fayetteville, NC  
 DATE DRILLED: 10/23/19  
 WEATHER: 60's, Sunny  
 ELEVATION: 207  
 DRILL CREW: Quantex  
 LOGGED BY: M.Lumpkin

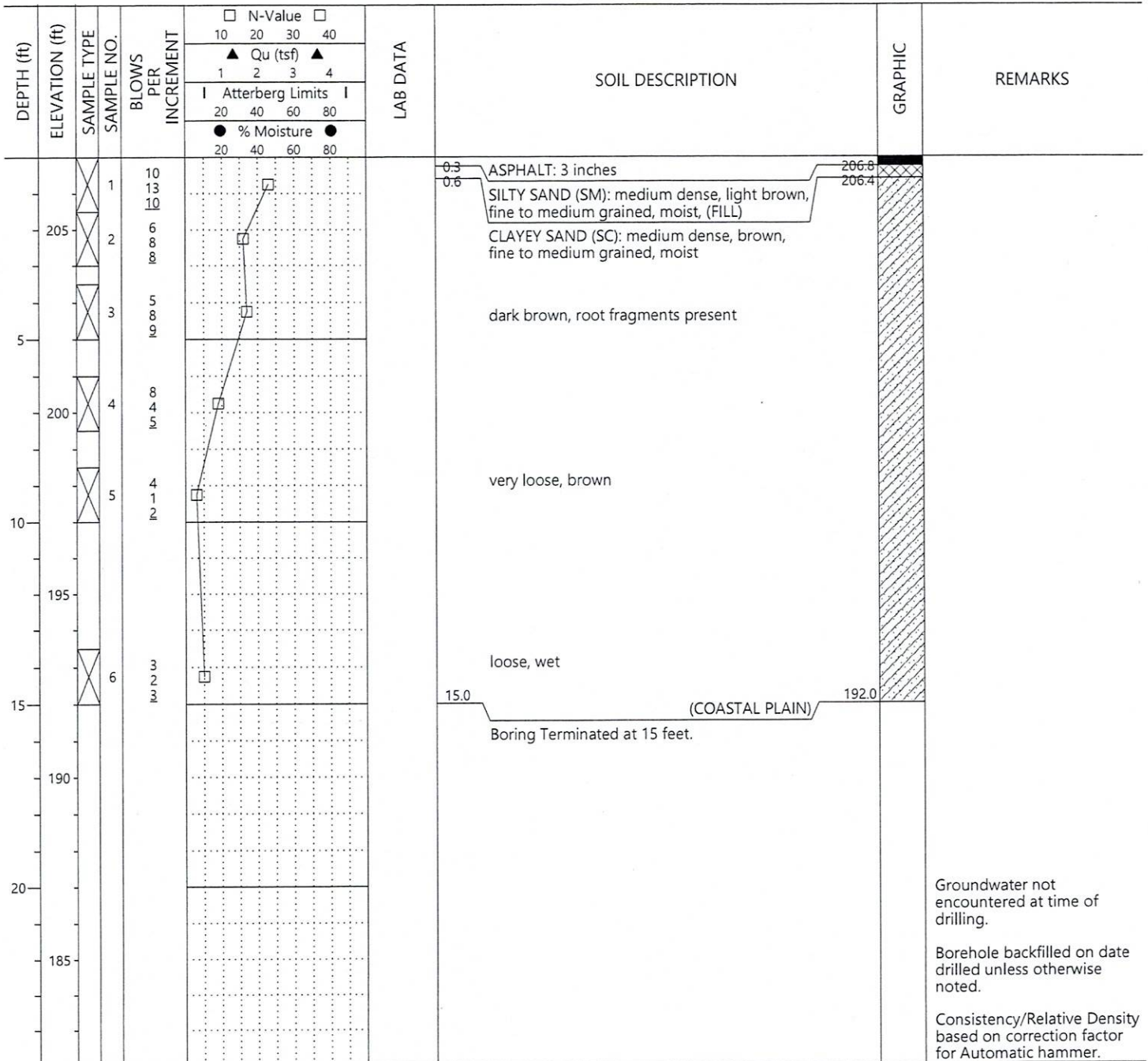

SAMPLE TYPE  Split Spoon

- |   |   |  |
|---|---|--|
| <b>N-VALUE</b> STANDARD PENETRATION RESISTANCE (AASHTO T-206) | <b>REC</b> RECOVERY   | <b>LL:</b> LIQUID LIMIT <b>M:</b> NATURAL MOISTURE CONTENT       |
| <b>% MOISTURE</b> PERCENT NATURAL MOISTURE CONTENT            | <b>RQD</b> ROCK QUALITY DESIGNATION                           | <b>PL:</b> PLASTIC LIMIT <b>F:</b> PERCENT PASSING NO. 200 SIEVE |
| GROUNDWATER LEVEL IN THE BOREHOLE AT TIME OF DRILLING         | <b>UD</b> UNDISTURBED   | <b>PI:</b> PLASTICITY INDEX                                      |
| STABILIZED GROUNDWATER LEVEL                                  | <b>Qu</b> POCKET PENETROMETER UNCONFINED COMPRESSIVE STRENGTH |  |



Geotechnical, Environmental, and Materials Engineers

# LOG OF BORING

Designation: SB-21

Sheet 1 of 1

610 Spring Branch Road

Dunn, NC 28334

Office: (910) 292-2085

PROJECT NAME: PWC Annexation - Phase V, Area 25  
 PROJECT NUMBER: RD190493  
 DRILLING METHOD: Hollow Stem Auger  
 EQUIPMENT USED: GeoProbe 7822DT  
 HAMMER TYPE: Automatic  
 BORING LOCATION: See Boring Location Map (North)

LOCATION: Fayetteville, NC  
 DATE DRILLED: 10/23/19  
 WEATHER: 60's, Sunny  
 ELEVATION: 227  
 DRILL CREW: Quantex  
 LOGGED BY: M.Lumpkin

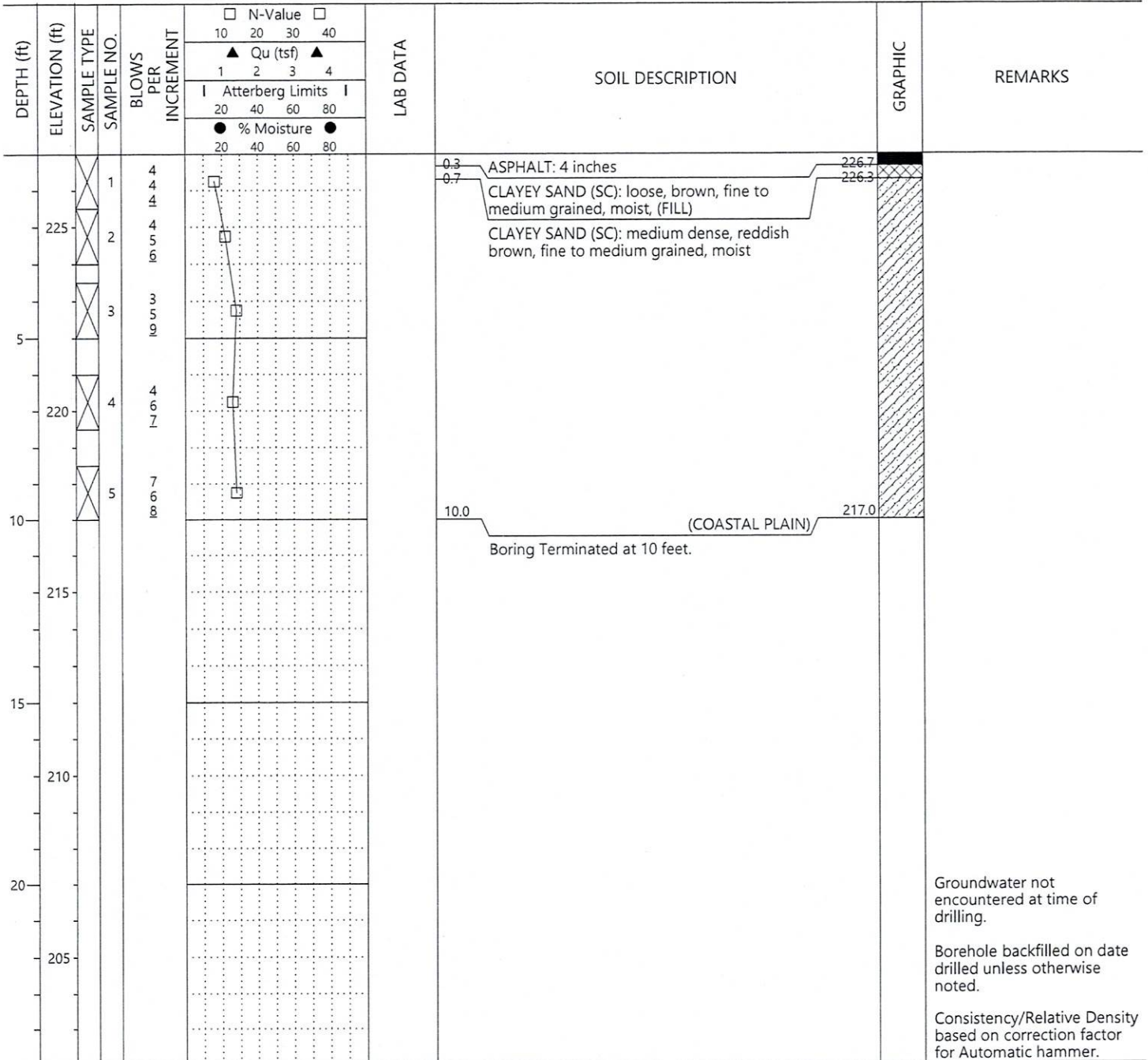

SAMPLE TYPE  Split Spoon

**N-VALUE** STANDARD PENETRATION RESISTANCE (AASHTO T-206)      **REC** RECOVERY      **LL:** LIQUID LIMIT    **M:** NATURAL MOISTURE CONTENT  
**% MOISTURE** PERCENT NATURAL MOISTURE CONTENT      **RQD** ROCK QUALITY DESIGNATION    **PL:** PLASTIC LIMIT    **F:** PERCENT PASSING NO. 200 SIEVE  
 GROUNDWATER LEVEL IN THE BOREHOLE AT TIME OF DRILLING    **UD** UNDISTURBED      **PI:** PLASTICITY INDEX  
 STABILIZED GROUNDWATER LEVEL      **Qu** POCKET PENETROMETER UNCONFINED COMPRESSIVE STRENGTH





# LOG OF BORING

Designation: SB-22

Sheet 1 of 1

610 Spring Branch Road  
Dunn, NC 28334  
Office: (910) 292-2085

Geotechnical, Environmental, and Materials Engineers

PROJECT NAME: PWC Annexation - Phase V, Area 25  
PROJECT NUMBER: RD190493  
DRILLING METHOD: Hollow Stem Auger  
EQUIPMENT USED: GeoProbe 7822DT  
HAMMER TYPE: Automatic  
BORING LOCATION: See Boring Location Map (North)

LOCATION: Fayetteville, NC  
DATE DRILLED: 10/23/19  
WEATHER: 60's, Sunny  
ELEVATION: 230  
DRILL CREW: Quantex  
LOGGED BY: M.Lumpkin

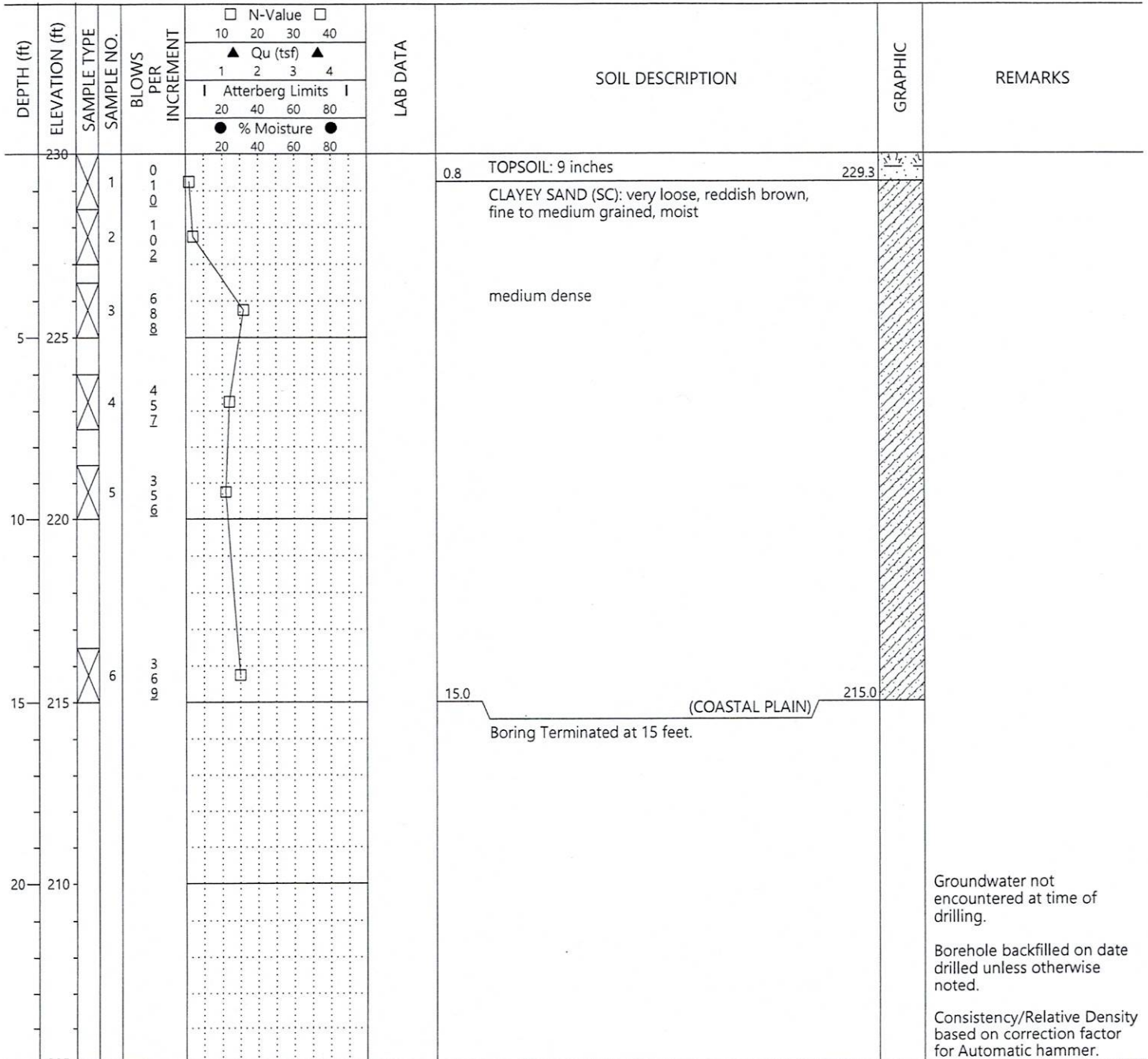

SAMPLE TYPE  Split Spoon

- N-VALUE** STANDARD PENETRATION RESISTANCE (AASHTO T-206)      **REC** RECOVERY      **LL:** LIQUID LIMIT    **M:** NATURAL MOISTURE CONTENT
- % MOISTURE** PERCENT NATURAL MOISTURE CONTENT      **RQD** ROCK QUALITY DESIGNATION    **PL:** PLASTIC LIMIT    **F:** PERCENT PASSING NO. 200 SIEVE
- GROUNDWATER LEVEL IN THE BOREHOLE AT TIME OF DRILLING    **UD** UNDISTURBED      **PI:** PLASTICITY INDEX
- STABILIZED GROUNDWATER LEVEL      **Qu** POCKET PENETROMETER UNCONFINED COMPRESSIVE STRENGTH

PROJECT NAME: PWC Annexation - Phase V, Area 25  
PROJECT NUMBER: RD190493  
DRILLING METHOD: Hollow Stem Auger  
EQUIPMENT USED: GeoProbe 7822DT  
HAMMER TYPE: Automatic  
BORING LOCATION: See Boring Location Map (North)

LOCATION: Fayetteville, NC  
DATE DRILLED: 10/23/19  
WEATHER: 60's, Sunny  
ELEVATION: 230  
DRILL CREW: Quantex  
LOGGED BY: M.Lumpkin

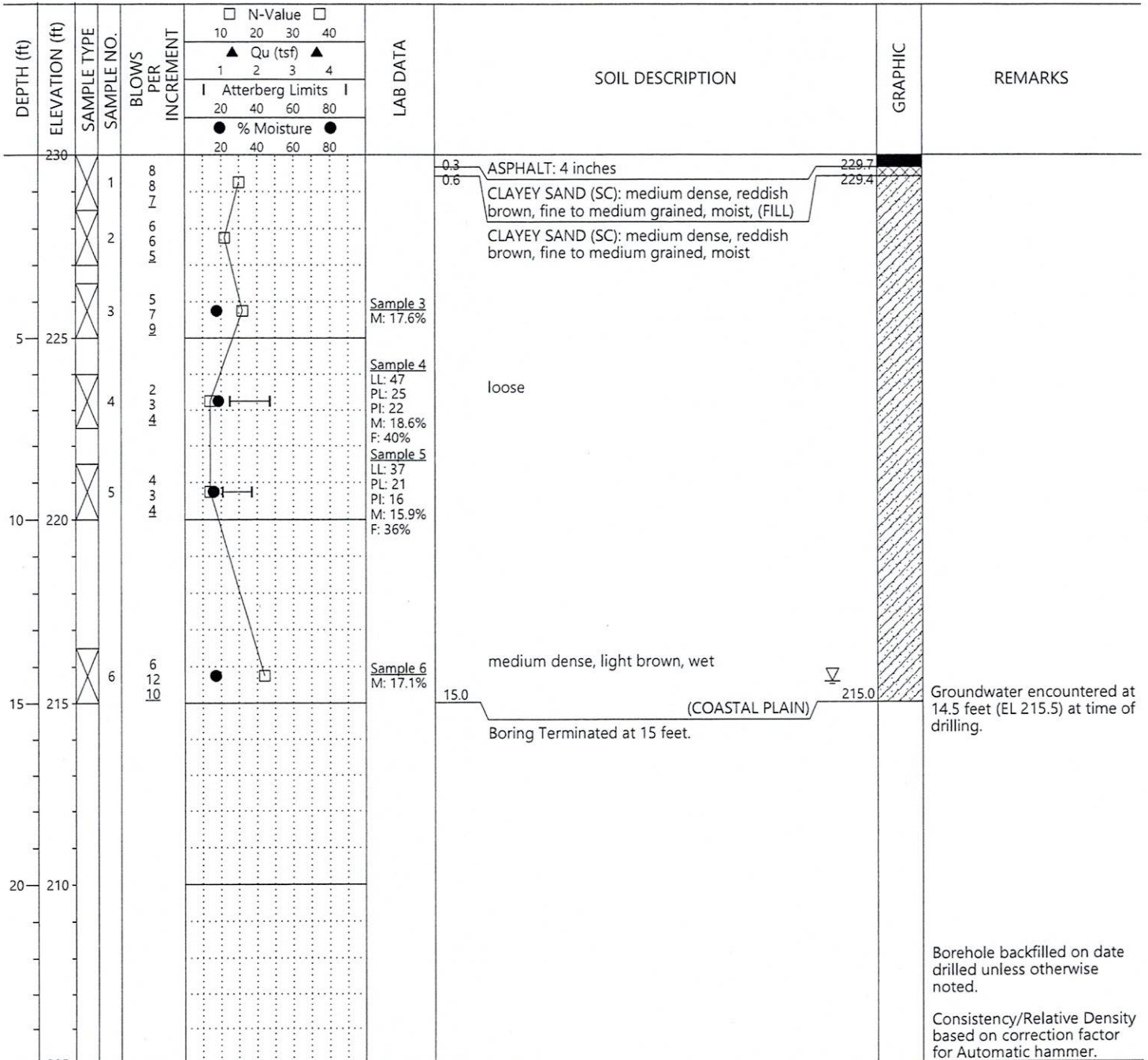

SAMPLE TYPE Split Spoon

**N-VALUE** STANDARD PENETRATION RESISTANCE (AASHTO T-206)

**% MOISTURE** PERCENT NATURAL MOISTURE CONTENT

GROUNDWATER LEVEL IN THE BOREHOLE AT TIME OF DRILLING

STABILIZED GROUNDWATER LEVEL

**REC** RECOVERY

**RQD** ROCK QUALITY DESIGNATION

**UD** UNDISTURBED

**Qu** POCKET PENETROMETER UNCONFINED COMPRESSIVE STRENGTH

**LL:** LIQUID LIMIT **M:** NATURAL MOISTURE CONTENT

**PL:** PLASTIC LIMIT **F:** PERCENT PASSING NO. 200 SIEVE

**PI:** PLASTICITY INDEX

Borehole backfilled on date drilled unless otherwise noted.

Consistency/Relative Density based on correction factor for Automatic hammer.

PROJECT NAME: PWC Annexation - Phase V, Area 25  
PROJECT NUMBER: RD190493  
DRILLING METHOD: Hollow Stem Auger  
EQUIPMENT USED: GeoProbe 7822DT  
HAMMER TYPE: Automatic  
BORING LOCATION: See Boring Location Map (North)

LOCATION: Fayetteville, NC  
DATE DRILLED: 10/23/19  
WEATHER: 60's, Sunny  
ELEVATION: 228  
DRILL CREW: Quantex  
LOGGED BY: M.Lumpkin

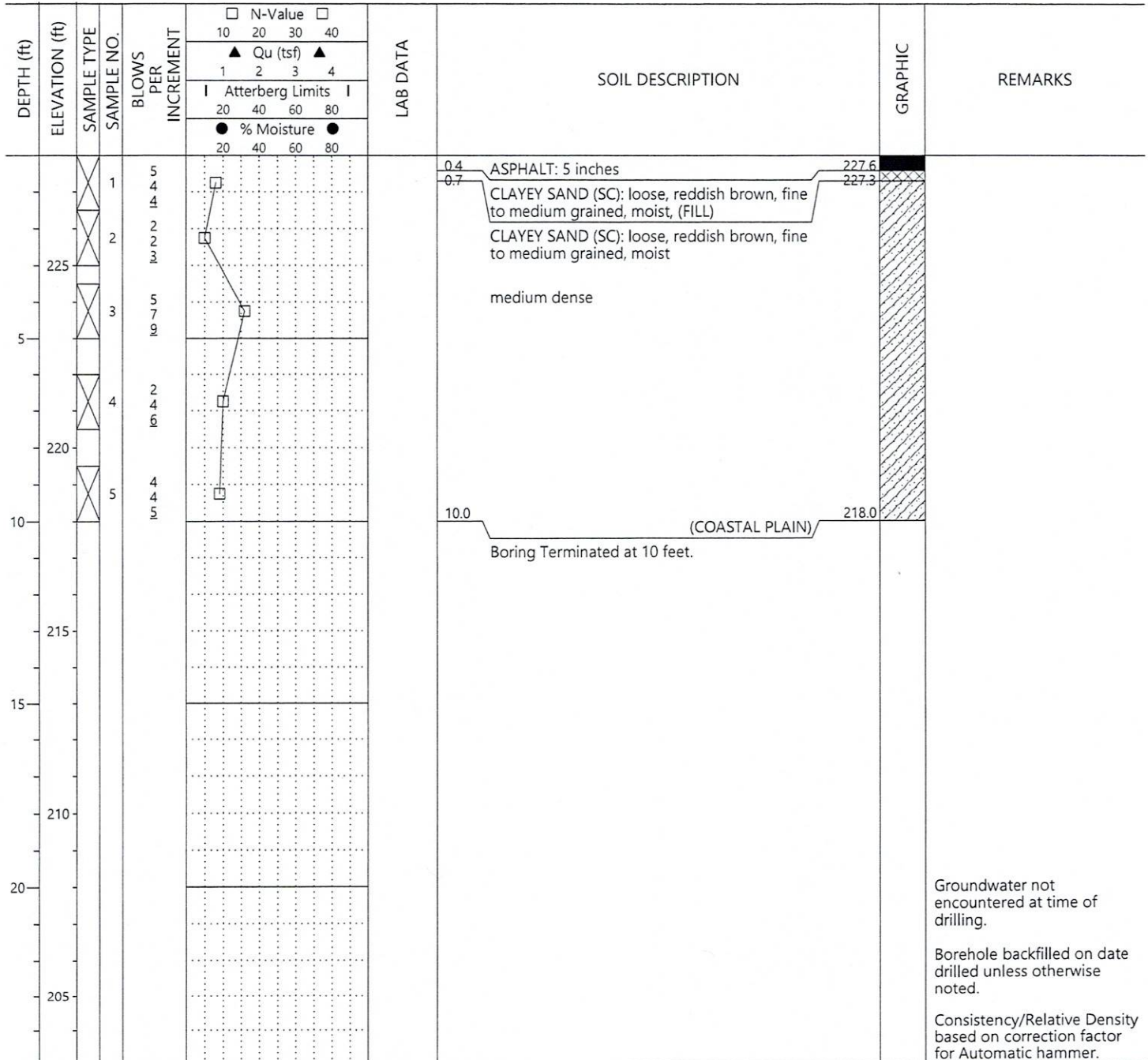

Groundwater not encountered at time of drilling.  
Borehole backfilled on date drilled unless otherwise noted.  
Consistency/Relative Density based on correction factor for Automatic hammer.

SAMPLE TYPE  Split Spoon

**N-VALUE** STANDARD PENETRATION RESISTANCE (AASHTO T-206)      **REC** RECOVERY      **LL:** LIQUID LIMIT      **M:** NATURAL MOISTURE CONTENT  
**% MOISTURE** PERCENT NATURAL MOISTURE CONTENT      **RQD** ROCK QUALITY DESIGNATION      **PL:** PLASTIC LIMIT      **F:** PERCENT PASSING NO. 200 SIEVE  
 GROUNDWATER LEVEL IN THE BOREHOLE AT TIME OF DRILLING      **UD** UNDISTURBED      **PI:** PLASTICITY INDEX  
 STABILIZED GROUNDWATER LEVEL      **Qu** POCKET PENETROMETER UNCONFINED COMPRESSIVE STRENGTH





Geotechnical, Environmental, and Materials Engineers

# LOG OF BORING

Designation: HA-02

Sheet 1 of 1

610 Spring Branch Road

Dunn, NC 28334

Office: (910) 292-2085

PROJECT NAME: PWC Annexation - Phase V, Area 25  
 PROJECT NUMBER: RD190493  
 DRILLING METHOD: Hand Auger  
 EQUIPMENT USED: Dynamic Cone Penetrometer  
 HAMMER TYPE: Manual  
 BORING LOCATION: See Boring Location Map (South)

LOCATION: Fayetteville, NC  
 DATE DRILLED: 10/30/19  
 WEATHER: 60's, Partly Sunny  
 ELEVATION: 178  
 DRILL CREW: Building & Earth  
 LOGGED BY: M.Lumpkin

DEPTH (ft)	ELEVATION (ft)	SAMPLE TYPE	SAMPLE NO.	DCP TO N-VALUE CORRECTION	LAB DATA				SOIL DESCRIPTION	GRAPHIC	REMARKS	
					□ N-Value	□	▲ Qu (tsf)	▲				
1	177.0		1	3	10	20	30	40	1.0	TOPSOIL: 12 inches		
2			2	3						SILTY SAND (SM): loose, light brown, fine to medium grained, moist		
3			3	4								
4			4	5								
5			5	14					4.7	medium dense		
6			6	15						CLAYEY SAND (SC): medium dense, reddish brown, fine to medium grained, moist		
7			7	15								
8	170		8	15						wet		
9			9	15								
10			10	15					10.0	(COASTAL PLAIN)		
										Boring Terminated at 10 feet.		
	165											
	160											
	155											

Groundwater not encountered at time of drilling.

Borehole backfilled on date drilled unless otherwise noted.

Consistency/Relative Density based on correction factor for DCP.

SAMPLE TYPE DCP Cone Penetration

- N-VALUE** STANDARD PENETRATION RESISTANCE (AASHTO T-206)      **REC** RECOVERY      **LL:** LIQUID LIMIT    **M:** NATURAL MOISTURE CONTENT
- % MOISTURE** PERCENT NATURAL MOISTURE CONTENT      **RQD** ROCK QUALITY DESIGNATION    **PL:** PLASTIC LIMIT    **F:** PERCENT PASSING NO. 200 SIEVE
- GROUNDWATER LEVEL IN THE BOREHOLE AT TIME OF DRILLING    **UD** UNDISTURBED      **PI:** PLASTICITY INDEX
- STABILIZED GROUNDWATER LEVEL      **Qu** POCKET PENETROMETER UNCONFINED COMPRESSIVE STRENGTH

PROJECT NAME: PWC Annexation - Phase V, Area 25  
PROJECT NUMBER: RD190493  
DRILLING METHOD: Hand Auger  
EQUIPMENT USED: Dynamic Cone Penetrometer  
HAMMER TYPE: Manual  
BORING LOCATION: See Boring Location Map (South)

LOCATION: Fayetteville, NC  
DATE DRILLED: 10/30/19  
WEATHER: 60's, Partly Sunny  
ELEVATION: 177  
DRILL CREW: Building & Earth  
LOGGED BY: M.Lumpkin

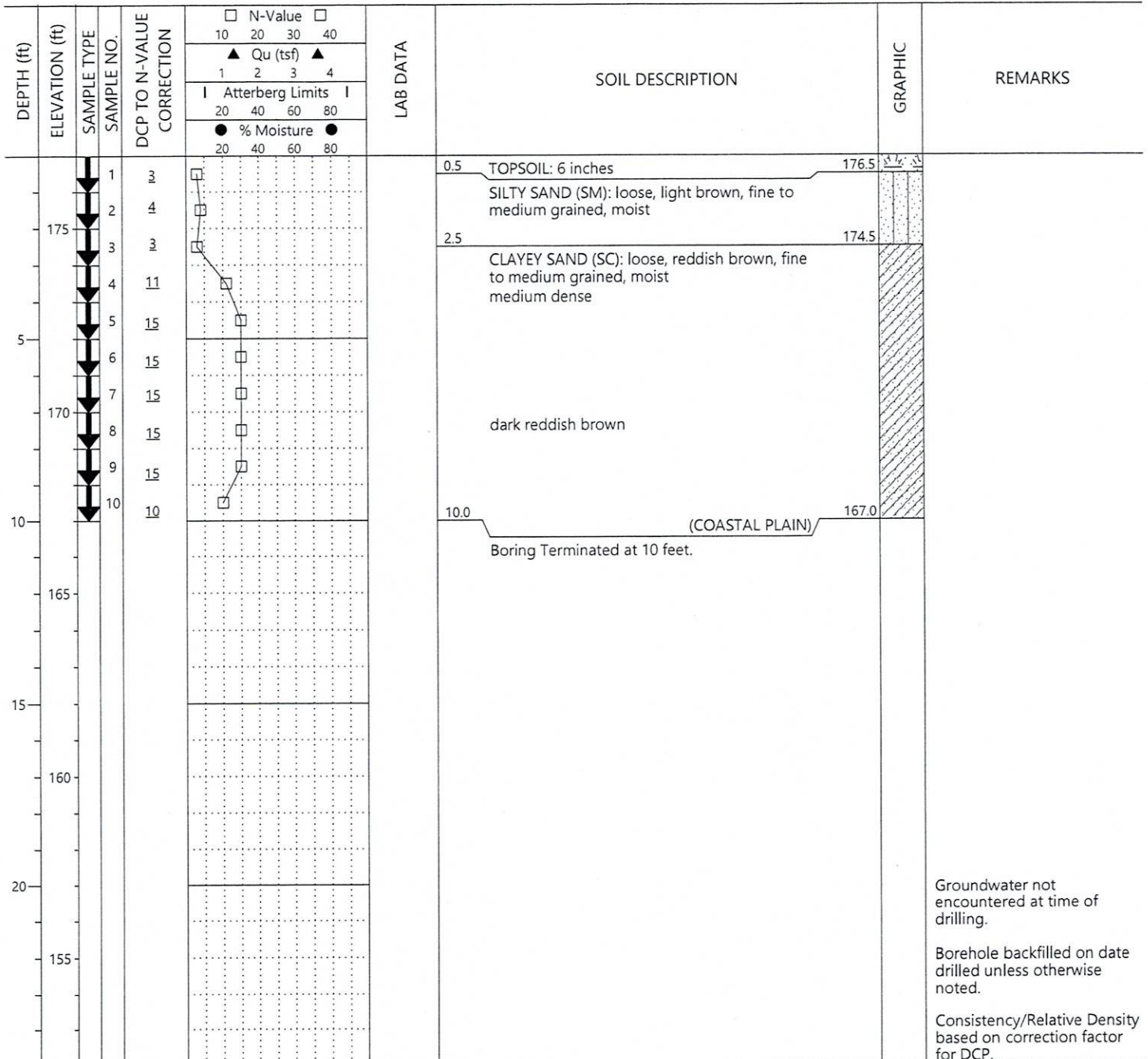

Groundwater not encountered at time of drilling.

Borehole backfilled on date drilled unless otherwise noted.

Consistency/Relative Density based on correction factor for DCP.

SAMPLE TYPE DCP Cone Penetration

**N-VALUE** STANDARD PENETRATION RESISTANCE (AASHTO T-206)

**REC** RECOVERY

**LL:** LIQUID LIMIT **M:** NATURAL MOISTURE CONTENT

**% MOISTURE** PERCENT NATURAL MOISTURE CONTENT

**RQD** ROCK QUALITY DESIGNATION

**PL:** PLASTIC LIMIT **F:** PERCENT PASSING NO. 200 SIEVE

GROUNDWATER LEVEL IN THE BOREHOLE AT TIME OF DRILLING

**UD** UNDISTURBED

**PI:** PLASTICITY INDEX

STABILIZED GROUNDWATER LEVEL

**Qu** POCKET PENETROMETER UNCONFINED COMPRESSIVE STRENGTH



Geotechnical, Environmental, and Materials Engineers

# LOG OF BORING

Designation: HA-04

Sheet 1 of 1

610 Spring Branch Road

Dunn, NC 28334

Office: (910) 292-2085

PROJECT NAME: PWC Annexation - Phase V, Area 25  
 PROJECT NUMBER: RD190493  
 DRILLING METHOD: Hand Auger  
 EQUIPMENT USED: Dynamic Cone Penetrometer  
 HAMMER TYPE: Manual  
 BORING LOCATION: See Boring Location Map (South)

LOCATION: Fayetteville, NC  
 DATE DRILLED: 10/28/19  
 WEATHER: 60's, Partly Sunny  
 ELEVATION: 188  
 DRILL CREW: Building & Earth  
 LOGGED BY: M.Lumpkin

DEPTH (ft)	ELEVATION (ft)	SAMPLE TYPE	SAMPLE NO.	DCP TO N-VALUE CORRECTION	N-Value				LAB DATA	SOIL DESCRIPTION	GRAPHIC	REMARKS
					10	20	30	40				
0.5	187.5								TOPSOIL: 6 inches			
2.8	185.2								SILTY SAND (SM): loose, brown, fine to medium grained, moist			
6.9	181.1								CLAYEY SAND (SC): medium dense, reddish brown, fine to medium grained, moist			
8.0	180.0								SILTY SAND (SM): medium dense, reddish brown, fine to medium grained, moist		Groundwater encountered at 7.8 feet (EL 180.2) at time of drilling.	
10.0	178.0								CLAYEY SAND (SC): medium dense, gray, fine to medium grained, moist			
10.0	178.0								(COASTAL PLAIN) Boring Terminated at 10 feet.			

SAMPLE TYPE DCP Cone Penetration

- N-VALUE** STANDARD PENETRATION RESISTANCE (AASHTO T-206)
- % MOISTURE** PERCENT NATURAL MOISTURE CONTENT
- GROUNDWATER LEVEL IN THE BOREHOLE AT TIME OF DRILLING
- STABILIZED GROUNDWATER LEVEL
- REC** RECOVERY
- RQD** ROCK QUALITY DESIGNATION
- UD** UNDISTURBED
- Qu** POCKET PENETROMETER UNCONFINED COMPRESSIVE STRENGTH
- LL:** LIQUID LIMIT
- M:** NATURAL MOISTURE CONTENT
- PL:** PLASTIC LIMIT
- F:** PERCENT PASSING NO. 200 SIEVE
- PI:** PLASTICITY INDEX

Borehole backfilled on date drilled unless otherwise noted.  
 Consistency/Relative Density based on correction factor for DCP.



Geotechnical, Environmental, and Materials Engineers

# LOG OF BORING

Designation: HA-05

Sheet 1 of 1

610 Spring Branch Road  
Dunn, NC 28334  
Office: (910) 292-2085

PROJECT NAME: PWC Annexation - Phase V, Area 25  
PROJECT NUMBER: RD190493  
DRILLING METHOD: Hand Auger  
EQUIPMENT USED: Dynamic Cone Penetrometer  
HAMMER TYPE: Manual  
BORING LOCATION: See Boring Location Map (North)

LOCATION: Fayetteville, NC  
DATE DRILLED: 10/28/19  
WEATHER: 60's, Partly Sunny  
ELEVATION: 205  
DRILL CREW: Building & Earth  
LOGGED BY: M.Lumpkin

DEPTH (ft)	ELEVATION (ft)	SAMPLE TYPE	SAMPLE NO.	DCP TO N-VALUE CORRECTION	N-Value				LAB DATA	SOIL DESCRIPTION	GRAPHIC	REMARKS
					10	20	30	40				
205												
			1	12						0.3	TOPSOIL: 4 inches	
			2	15							CLAYEY SAND (SC): medium dense, reddish brown, fine to medium grained, moist	
			3	15								
			4	15						3.5	SANDY LEAN CLAY (CL): very stiff, gray, fine grained, moist	
5	200		5	15								
			6	15								
			7	15								
			8	15								
			9	15								
10	195		10	15						10.0	(COASTAL PLAIN) Boring Terminated at 10 feet.	
15	190											
20	185											
												Groundwater not encountered at time of drilling.
												Borehole backfilled on date drilled unless otherwise noted.
												Consistency/Relative Density based on correction factor for DCP.

SAMPLE TYPE DCP Cone Penetration

- N-VALUE** STANDARD PENETRATION RESISTANCE (AASHTO T-206)      **REC** RECOVERY      **LL:** LIQUID LIMIT    **M:** NATURAL MOISTURE CONTENT
- % MOISTURE** PERCENT NATURAL MOISTURE CONTENT      **RQD** ROCK QUALITY DESIGNATION    **PL:** PLASTIC LIMIT    **F:** PERCENT PASSING NO. 200 SIEVE
- GROUNDWATER LEVEL IN THE BOREHOLE AT TIME OF DRILLING    **UD** UNDISTURBED      **PI:** PLASTICITY INDEX
- STABILIZED GROUNDWATER LEVEL      **Qu** POCKET PENETROMETER UNCONFINED COMPRESSIVE STRENGTH





PROJECT NAME: PWC Annexation - Phase V, Area 25  
PROJECT NUMBER: RD190493  
DRILLING METHOD: Hand Auger  
EQUIPMENT USED: Dynamic Cone Penetrometer  
HAMMER TYPE: Manual  
BORING LOCATION: See Boring Location Map (South)

LOCATION: Fayetteville, NC  
DATE DRILLED: 11/5/19  
WEATHER: 50's, Partly Sunny  
ELEVATION: 179  
DRILL CREW: Building & Earth  
LOGGED BY: M.Lumpkin

DEPTH (ft)	ELEVATION (ft)	SAMPLE TYPE	SAMPLE NO.	DCP TO N-VALUE CORRECTION	N-Value				LAB DATA	SOIL DESCRIPTION	GRAPHIC	REMARKS
					10	20	30	40				
					□ N-Value □ ▲ Qu (tsf) ▲   Atterberg Limits   ● % Moisture ●							
0.4	178.6		1	5								
2.5	176.5		2	6								
10.0	169.0		10	15					(COASTAL PLAIN)			
									Boring Terminated at 10 feet.			

SAMPLE TYPE  DCP Cone Penetration

**N-VALUE** STANDARD PENETRATION RESISTANCE (AASHTO T-206)      **REC** RECOVERY      **LL:** LIQUID LIMIT      **M:** NATURAL MOISTURE CONTENT  
**% MOISTURE** PERCENT NATURAL MOISTURE CONTENT      **RQD** ROCK QUALITY DESIGNATION      **PL:** PLASTIC LIMIT      **F:** PERCENT PASSING NO. 200 SIEVE  
 GROUNDWATER LEVEL IN THE BOREHOLE AT TIME OF DRILLING      **UD** UNDISTURBED      **PI:** PLASTICITY INDEX  
 STABILIZED GROUNDWATER LEVEL      **Qu** POCKET PENETROMETER UNCONFINED COMPRESSIVE STRENGTH



Geotechnical, Environmental, and Materials Engineers

# LOG OF BORING

Designation: HA-07

Sheet 1 of 1

610 Spring Branch Road  
Dunn, NC 28334  
Office: (910) 292-2085

PROJECT NAME: PWC Annexation - Phase V, Area 25  
PROJECT NUMBER: RD190493  
DRILLING METHOD: Hand Auger  
EQUIPMENT USED: Dynamic Cone Penetrometer  
HAMMER TYPE: Manual  
BORING LOCATION: See Boring Location Map (South)

LOCATION: Fayetteville, NC  
DATE DRILLED: 11/5/19  
WEATHER: 50's, Partly Sunny  
ELEVATION: 178  
DRILL CREW: Building & Earth  
LOGGED BY: M.Lumpkin

DEPTH (ft)	ELEVATION (ft)	SAMPLE TYPE	SAMPLE NO.	DCP TO N-VALUE CORRECTION	N-Value				LAB DATA	SOIL DESCRIPTION	GRAPHIC	REMARKS
					10	20	30	40				
					□ N-Value □ ▲ Qu (tsf) ▲   Atterberg Limits   ● % Moisture ●							
			1	6						1.0	TOPSOIL: 12 inches	177.0
			2	15							SILTY SAND (SM): medium dense, brown, fine to medium grained, moist	
			3	15								
	175		4	8								
			5	10						5.0	reddish brown	173.0
	5		6	15							CLAYEY SAND (SC): medium dense, reddish brown, fine to medium grained, wet	
			7	15						7.0	(COASTAL PLAIN)	171.0
	170										Boring Terminated at 7 feet.	
	10											
	165											
	15											
	160											
	20											
	155											

Groundwater encountered at 5.5 feet (EL 172.5) at time of drilling.

Borehole backfilled on date drilled unless otherwise noted.

Consistency/Relative Density based on correction factor for DCP.

SAMPLE TYPE DCP Cone Penetration

- N-VALUE** STANDARD PENETRATION RESISTANCE (AASHTO T-206)      **REC** RECOVERY      **LL:** LIQUID LIMIT    **M:** NATURAL MOISTURE CONTENT
- % MOISTURE** PERCENT NATURAL MOISTURE CONTENT      **RQD** ROCK QUALITY DESIGNATION    **PL:** PLASTIC LIMIT    **F:** PERCENT PASSING NO. 200 SIEVE
- GROUNDWATER LEVEL IN THE BOREHOLE AT TIME OF DRILLING    **UD** UNDISTURBED      **PI:** PLASTICITY INDEX
- STABILIZED GROUNDWATER LEVEL      **Qu** POCKET PENETROMETER UNCONFINED COMPRESSIVE STRENGTH

PROJECT NAME: PWC Annexation - Phase V, Area 25  
 PROJECT NUMBER: RD190493  
 DRILLING METHOD: Hand Auger  
 EQUIPMENT USED: Dynamic Cone Penetrometer  
 HAMMER TYPE: Manual  
 BORING LOCATION: See Boring Location Map (South)

LOCATION: Fayetteville, NC  
 DATE DRILLED: 11/5/19  
 WEATHER: 50's, Partly Sunny  
 ELEVATION: 218  
 DRILL CREW: Building & Earth  
 LOGGED BY: M.Lumpkin

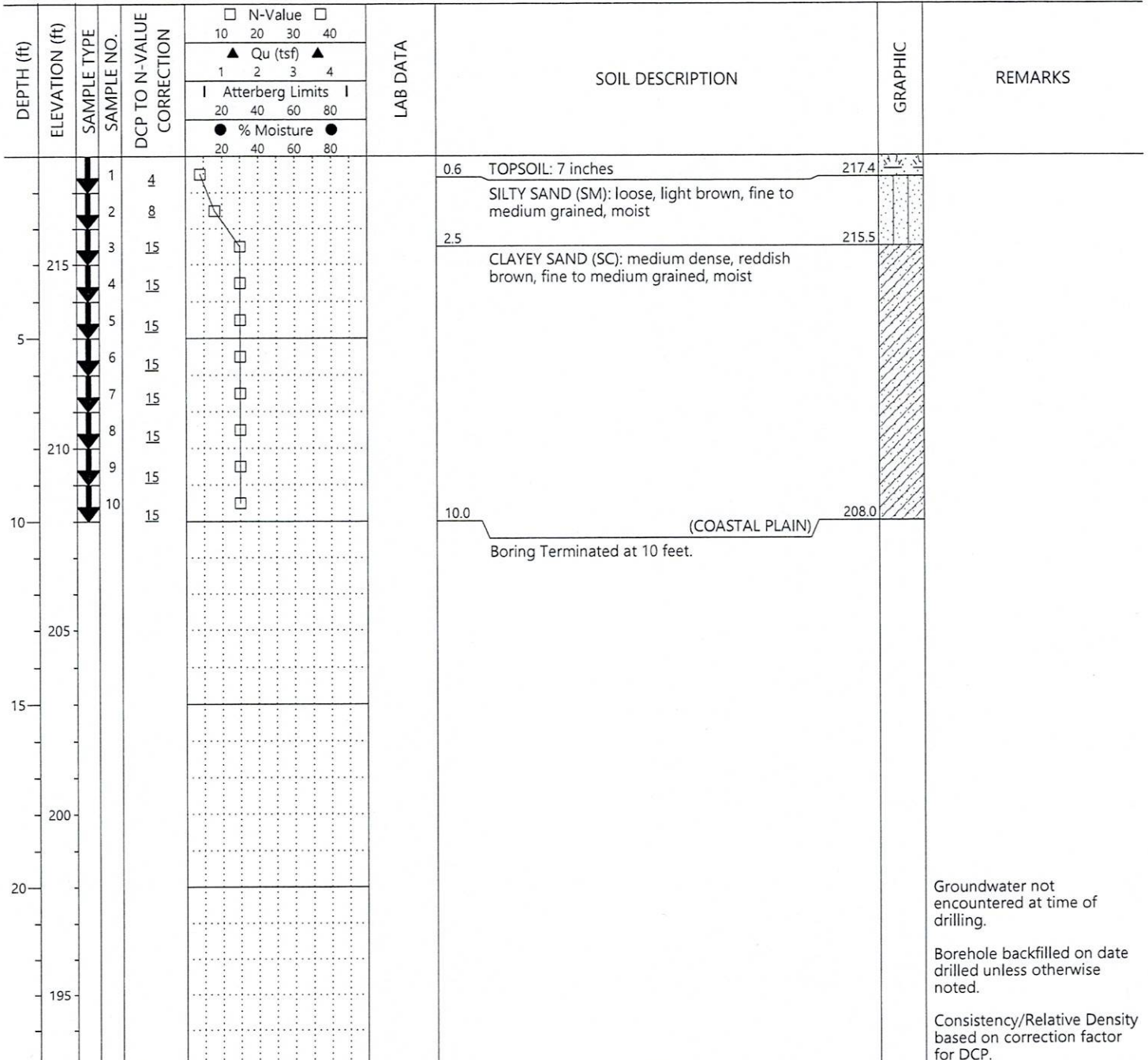

Groundwater not encountered at time of drilling.

Borehole backfilled on date drilled unless otherwise noted.

Consistency/Relative Density based on correction factor for DCP.

SAMPLE TYPE DCP Cone Penetration

**N-VALUE** STANDARD PENETRATION RESISTANCE (AASHTO T-206)

**% MOISTURE** PERCENT NATURAL MOISTURE CONTENT

GROUNDWATER LEVEL IN THE BOREHOLE AT TIME OF DRILLING

STABILIZED GROUNDWATER LEVEL

**REC** RECOVERY

**RQD** ROCK QUALITY DESIGNATION

**UD** UNDISTURBED

**Qu** POCKET PENETROMETER UNCONFINED COMPRESSIVE STRENGTH

**LL:** LIQUID LIMIT **M:** NATURAL MOISTURE CONTENT

**PL:** PLASTIC LIMIT **F:** PERCENT PASSING NO. 200 SIEVE

**PI:** PLASTICITY INDEX

PROJECT NAME: PWC Annexation - Phase V, Area 25  
PROJECT NUMBER: RD190493  
DRILLING METHOD: Hand Auger  
EQUIPMENT USED: Dynamic Cone Penetrometer  
HAMMER TYPE: Manual  
BORING LOCATION: See Boring Location Map (North)

LOCATION: Fayetteville, NC  
DATE DRILLED: 11/5/19  
WEATHER: 50's, Partly Sunny  
ELEVATION: 190  
DRILL CREW: Building & Earth  
LOGGED BY: M.Lumpkin

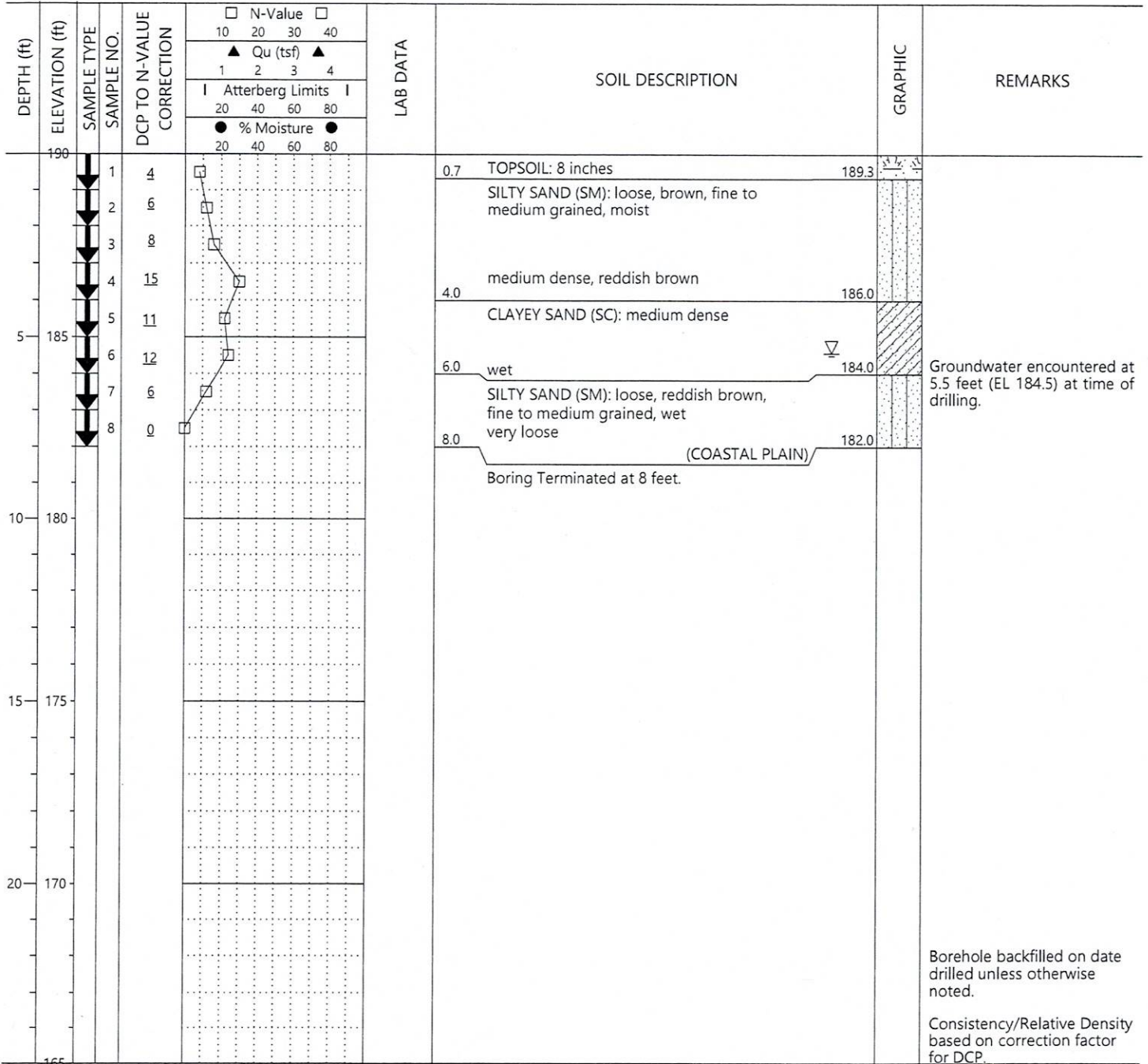

SAMPLE TYPE DCP Cone Penetration

**N-VALUE** STANDARD PENETRATION RESISTANCE (AASHTO T-206)

**% MOISTURE** PERCENT NATURAL MOISTURE CONTENT

GROUNDWATER LEVEL IN THE BOREHOLE AT TIME OF DRILLING

STABILIZED GROUNDWATER LEVEL

**REC** RECOVERY

**RQD** ROCK QUALITY DESIGNATION

**UD** UNDISTURBED

**Qu** POCKET PENETROMETER UNCONFINED COMPRESSIVE STRENGTH

**LL:** LIQUID LIMIT **M:** NATURAL MOISTURE CONTENT

**PL:** PLASTIC LIMIT **F:** PERCENT PASSING NO. 200 SIEVE

**PI:** PLASTICITY INDEX

Borehole backfilled on date drilled unless otherwise noted.

Consistency/Relative Density based on correction factor for DCP.

PROJECT NAME: PWC Annexation - Phase V, Area 25  
PROJECT NUMBER: RD190493  
DRILLING METHOD: Hand Auger  
EQUIPMENT USED: Dynamic Cone Penetrometer  
HAMMER TYPE: Manual  
BORING LOCATION: See Boring Location Map (North)

LOCATION: Fayetteville, NC  
DATE DRILLED: 11/5/19  
WEATHER: 50's, Partly Sunny  
ELEVATION: 223  
DRILL CREW: Building & Earth  
LOGGED BY: M.Lumpkin

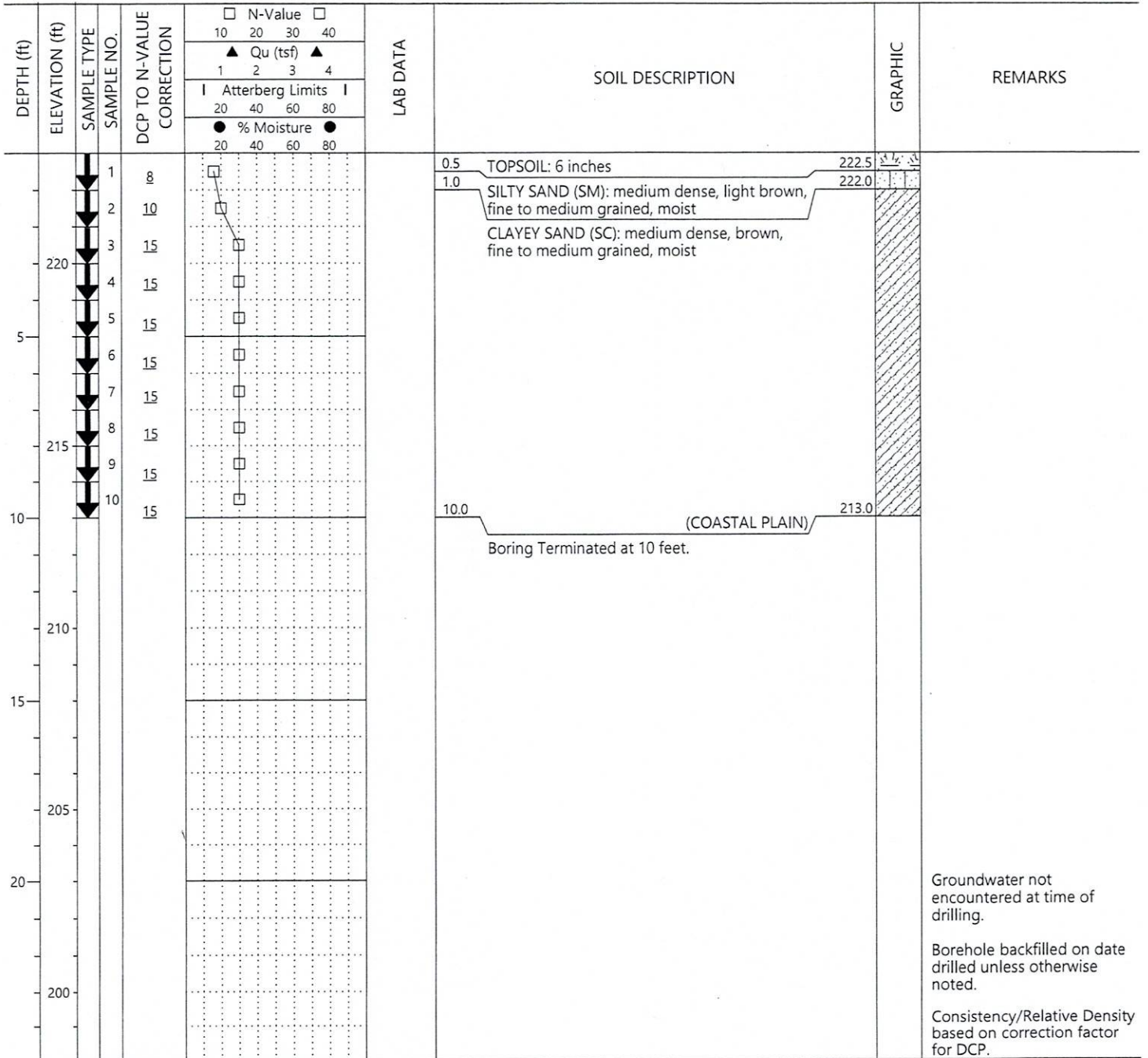

SAMPLE TYPE  DCP Cone Penetration

**N-VALUE** STANDARD PENETRATION RESISTANCE (AASHTO T-206)

**% MOISTURE** PERCENT NATURAL MOISTURE CONTENT

 GROUNDWATER LEVEL IN THE BOREHOLE AT TIME OF DRILLING

 STABILIZED GROUNDWATER LEVEL

**REC** RECOVERY

**RQD** ROCK QUALITY DESIGNATION

**UD** UNDISTURBED

**Qu** POCKET PENETROMETER UNCONFINED COMPRESSIVE STRENGTH

**LL:** LIQUID LIMIT **M:** NATURAL MOISTURE CONTENT

**PL:** PLASTIC LIMIT **F:** PERCENT PASSING NO. 200 SIEVE

**PI:** PLASTICITY INDEX

PROJECT NAME: PWC Annexation - Phase V, Area 25  
PROJECT NUMBER: RD190493  
DRILLING METHOD: Hand Auger  
EQUIPMENT USED: Dynamic Cone Penetrometer  
HAMMER TYPE: Manual  
BORING LOCATION: See Boring Location Map (North)

LOCATION: Fayetteville, NC  
DATE DRILLED: 10/28/19  
WEATHER: 60's, Partly Sunny  
ELEVATION: 208  
DRILL CREW: Building & Earth  
LOGGED BY: M.Lumpkin

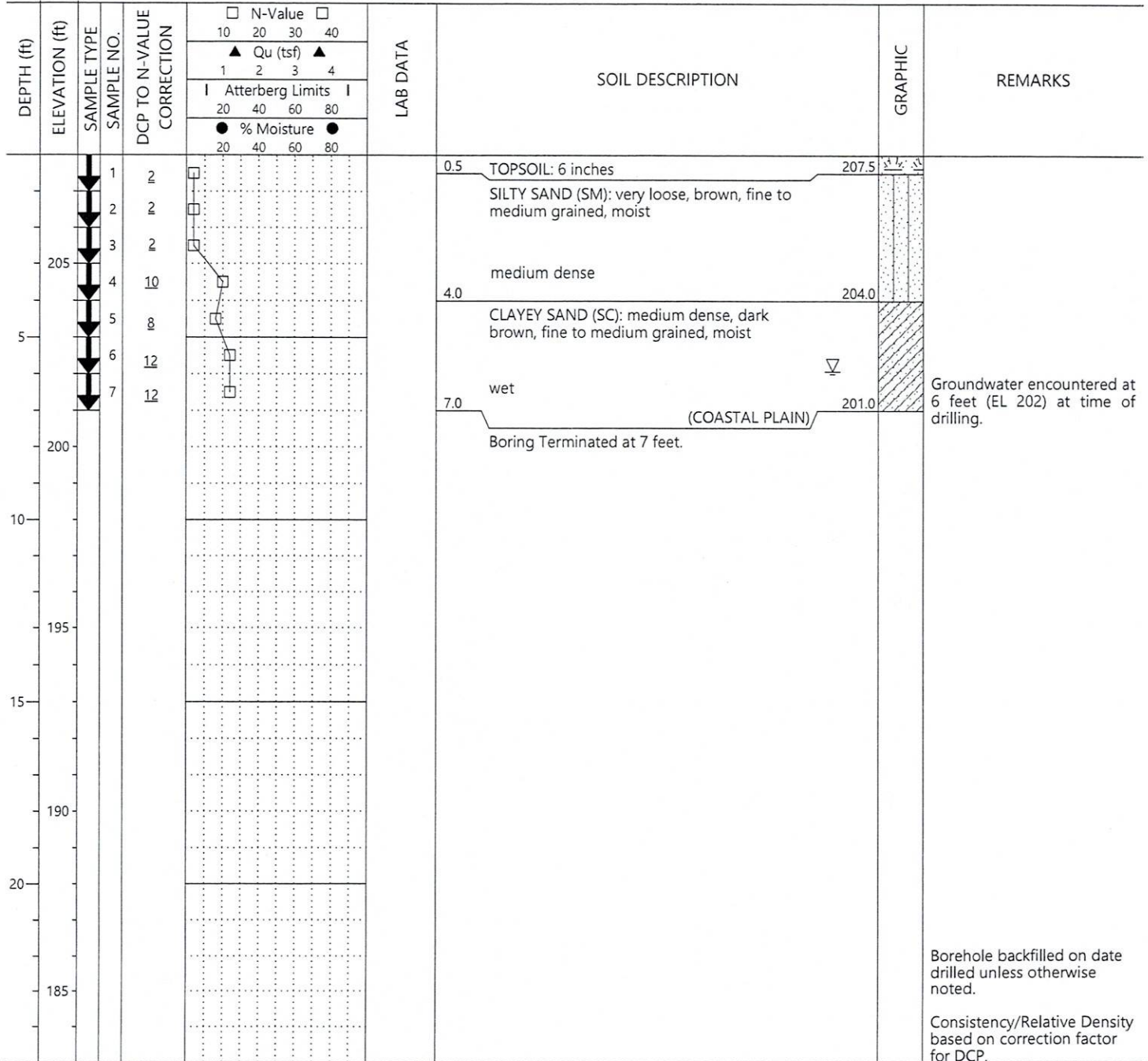

SAMPLE TYPE DCP Cone Penetration

**N-VALUE** STANDARD PENETRATION RESISTANCE (AASHTO T-206)

**% MOISTURE** PERCENT NATURAL MOISTURE CONTENT

GROUNDWATER LEVEL IN THE BOREHOLE AT TIME OF DRILLING

STABILIZED GROUNDWATER LEVEL

**REC** RECOVERY

**RQD** ROCK QUALITY DESIGNATION

**UD** UNDISTURBED

**Qu** POCKET PENETROMETER UNCONFINED COMPRESSIVE STRENGTH

**LL:** LIQUID LIMIT **M:** NATURAL MOISTURE CONTENT

**PL:** PLASTIC LIMIT **F:** PERCENT PASSING NO. 200 SIEVE

**PI:** PLASTICITY INDEX

Borehole backfilled on date drilled unless otherwise noted.

Consistency/Relative Density based on correction factor for DCP.



# LOG OF BORING

Designation: HA-12

Sheet 1 of 1

610 Spring Branch Road  
Dunn, NC 28334  
Office: (910) 292-2085

Geotechnical, Environmental, and Materials Engineers

PROJECT NAME: PWC Annexation - Phase V, Area 25  
PROJECT NUMBER: RD190493  
DRILLING METHOD: Hand Auger  
EQUIPMENT USED: Dynamic Cone Penetrometer  
HAMMER TYPE: Manual  
BORING LOCATION: See Boring Location Map (North)

LOCATION: Fayetteville, NC  
DATE DRILLED: 10/28/19  
WEATHER: 60's, Partly Sunny  
ELEVATION: 227  
DRILL CREW: Building & Earth  
LOGGED BY: M.Lumpkin

DEPTH (ft)	ELEVATION (ft)	SAMPLE TYPE	SAMPLE NO.	DCP TO N-VALUE CORRECTION	LAB DATA				SOIL DESCRIPTION	GRAPHIC	REMARKS
					□ N-Value	□	▲ Qu (tsf)	▲			
					10 20 30 40	1 2 3 4	Atterberg Limits				
					20 40 60 80	20 40 60 80					
					● % Moisture	●					
					20 40 60 80	20 40 60 80					
1	225	DCP Cone Penetration	1	4	10	1			1.0	TOPSOIL: 12 inches	
2			2	3	20	2			226.0	CLAYEY SAND (SC): loose, brown, fine to medium grained, moist	
3			3	8	30	3					
4			4	11	40	4					
5			5	14	50					medium dense, grayish brown	
6			6	14	60						
7			7	15	70						
8			8	15	80					reddish brown	
9			9	15	90						
10			10	14	100				10.0	(COASTAL PLAIN)	
									217.0	Boring Terminated at 10 feet.	
15	215										
20	210										
205	205										Groundwater not encountered at time of drilling. Borehole backfilled on date drilled unless otherwise noted. Consistency/Relative Density based on correction factor for DCP.

SAMPLE TYPE DCP Cone Penetration

**N-VALUE** STANDARD PENETRATION RESISTANCE (AASHTO T-206)      **REC** RECOVERY      **LL:** LIQUID LIMIT    **M:** NATURAL MOISTURE CONTENT  
**% MOISTURE** PERCENT NATURAL MOISTURE CONTENT      **RQD** ROCK QUALITY DESIGNATION    **PL:** PLASTIC LIMIT    **F:** PERCENT PASSING NO. 200 SIEVE  
 GROUNDWATER LEVEL IN THE BOREHOLE AT TIME OF DRILLING    **UD** UNDISTURBED      **PI:** PLASTICITY INDEX  
 STABILIZED GROUNDWATER LEVEL      **Qu** POCKET PENETROMETER UNCONFINED COMPRESSIVE STRENGTH

Birmingham, AL • Auburn, AL • Huntsville, AL • Montgomery, AL • Mobile, AL • Tuscaloosa, AL  
 Columbus, GA • Louisville, KY • Raleigh, NC • Dunn, NC • Jacksonville, NC  
 Springdale, AR • Little Rock, AR • Tulsa, OK • Oklahoma City, OK • Durant, OK

## LABORATORY TEST PROCEDURES

A brief description of the laboratory tests performed is provided in the following sections.

### *DESCRIPTION OF SOILS (VISUAL-MANUAL PROCEDURE) (ASTM D2488)*

The soil samples were visually examined by our engineer and soil descriptions were provided. Representative samples were then selected and tested in accordance with the aforementioned laboratory-testing program to determine soil classifications and engineering properties. This data was used to correlate our visual descriptions with the Unified Soil Classification System (USCS).

### *POCKET PENETROMETER*

Pocket Penetrometer tests were performed on cohesive soil samples. The pocket penetrometer provides a consistency classification, and an indication of the soils unconfined compressive strength ( $Q_u$ ).

### *NATURAL MOISTURE CONTENT (ASTM D2216)*

Natural moisture contents (M%) were determined on selected samples. The natural moisture content is the ratio, expressed as a percentage, of the weight of water in a given amount of soil to the weight of solid particles.

### *ATTERBERG LIMITS (ASTM D4318)*

The Atterberg Limits test was performed to evaluate the soil's plasticity characteristics. The soil Plasticity Index (PI) is representative of this characteristic and is bracketed by the Liquid Limit (LL) and the Plastic Limit (PL). The Liquid Limit is the moisture content at which the soil will flow as a heavy viscous fluid. The Plastic Limit is the moisture content at which the soil is between "plastic" and the semi-solid stage. The Plasticity Index ( $PI = LL - PL$ ) is a frequently used indicator for a soil's potential for volume change. Typically, a soil's potential for volume change increases with higher plasticity indices.

### *MATERIAL FINER THAN NO. 200 SIEVE BY WASHING (ASTM D1140)*

Grain-size tests were performed to determine the partial soil particle size distribution. The amount of material finer than the openings on the No. 200 sieve (0.075 mm) was determined by washing soil over the No. 200 sieve. The results of wash #200 tests are presented on the boring logs included in this report and in the table of laboratory test results.



#### *STANDARD PROCTOR COMPACTION TEST (ASTM D698)*

Standard Proctor compaction tests were performed to determine the maximum dry density and optimum moisture content for the soil, for use as a comparative basis during fill placement. The Standard Proctor test consists of the compaction of soil with known moisture content into a steel mold of fixed height and diameter. The soil is compacted in the mold in three lifts of equal volume using a 5.5 lb. manual hammer with a 12-inch free fall, to produce a consistent compactive effort. The test procedure is repeated on samples at several different moisture contents until a curve showing the relationship between moisture content and dry density of the soil is established. From this curve, the maximum dry density (peak density value) and optimum moisture content (moisture content correlating to the maximum dry density) are obtained.

#### *WATER SOLUBLE CHLORIDE AND SULFATE, RESISTIVITY AND PH (DIPRA)*

Representative samples of soil and groundwater are collected and analyzed for sulfates, chlorides, resistivity, and pH to evaluate the corrosion potential of the site. These tests were performed in order to obtain information regarding the soil's relative ability to transmit electrical currents and thus, corrode metals places in contact with it. Soil sulfate content tests were performed on the samples to evaluate sulfate attack on buried concrete. The test results are compared to published standards applicable to the project construction for assignment of corrosion potential ratings.

## LABORATORY TEST RESULTS

The results of the laboratory testing are presented in the following tables.

BORING NO.	DEPTH	MOISTURE CONTENT (%)	LIQUID LIMIT	PLASTIC LIMIT	PLASTICITY INDEX	% PASSING #200 SIEVE	CLASSIFICATION
SB-01	1.5 - 3.0	9.6					
SB-01	3.5 - 5.0	14.8	15	15	NP	14	SM
SB-01	6.0 - 7.5	14.8					
SB-01	8.5 - 10.0	15.9	30	15	15	49	SC
SB-01	18.5 - 20.0	10.2	25	14	11	66	CL
SB-01A	1.5 - 3.0	15.1					
SB-01A	3.5 - 5.0	14.8					
SB-01A	6.0 - 7.5	7.8	39	22	17	10	SP-SC
SB-01A	8.5 - 10.0	12.6	38	18	20	63	CL
SB-01A	13.5 - 15.0	15.6					
SB-02	1.5 - 3.0	14.5					
SB-02	3.5 - 5.0	9.2					
SB-02	6.0 - 7.5	11.6	30	18	12	30	SC
SB-02	8.5 - 10.0	21.4	67	30	37	63	CH
SB-04	1.5 - 3.0	7.8					
SB-04	3.5 - 5.0	17.3	57	29	28	36	SC
SB-04	6.0 - 7.5	18.1					
SB-04	8.5 - 10.0	9.9	21	17	4	21	SC-SM
SB-07	7.0 - 8.0	8.9					
SB-07	9.0 - 10.0	15.7	23	19	4	20	SC-SM
SB-09	3.5 - 5.0	16.0					
SB-09	6.0 - 7.5	10.7	18	15	3	29	SM
SB-09	8.5 - 10.0	27.2	79	34	45	91	CH
SB-09	13.5 - 15.0	24.9					
SB-11	1.5 - 3.0	4.9					
SB-11	3.5 - 5.0	6.7					
SB-11	6.0 - 7.5	6.6	21	19	2	14	SM
SB-11	8.5 - 10.0	10.9	23	19	4	20	SC-SM
SB-23	3.5 - 5.0	17.6					
SB-23	6.0 - 7.5	18.6	47	25	22	40	SC
SB-23	8.5 - 10.0	15.9	37	21	16	36	SC

**TABLE L-1: General Soil Classification Test Results**

*Soils with a Liquid Limit (LL) greater than 50 and Plasticity Index (PI) greater than 25 usually exhibit significant volume change with varying moisture content and are considered to be highly plastic*

**LABORATORY TEST RESULTS**

The results of the laboratory testing are presented in the following tables.

BORING NO.	DEPTH	MOISTURE CONTENT (%)	LIQUID LIMIT	PLASTIC LIMIT	PLASTICITY INDEX	% PASSING #200 SIEVE	CLASSIFICATION
SB-23	13.5 - 15.0	17.1					

**TABLE L-1: General Soil Classification Test Results**

*Soils with a Liquid Limit (LL) greater than 50 and Plasticity Index (PI) greater than 25 usually exhibit significant volume change with varying moisture content and are considered to be highly plastic*

Geotechnical, Environmental, and Materials Engineers

**PROJECT NAME** PWC Annexation - Phase V, Area 25

**PROJECT NUMBER** RD190493

**CLIENT** MKR, Inc.

**PROJECT LOCATION** Fayetteville, NC

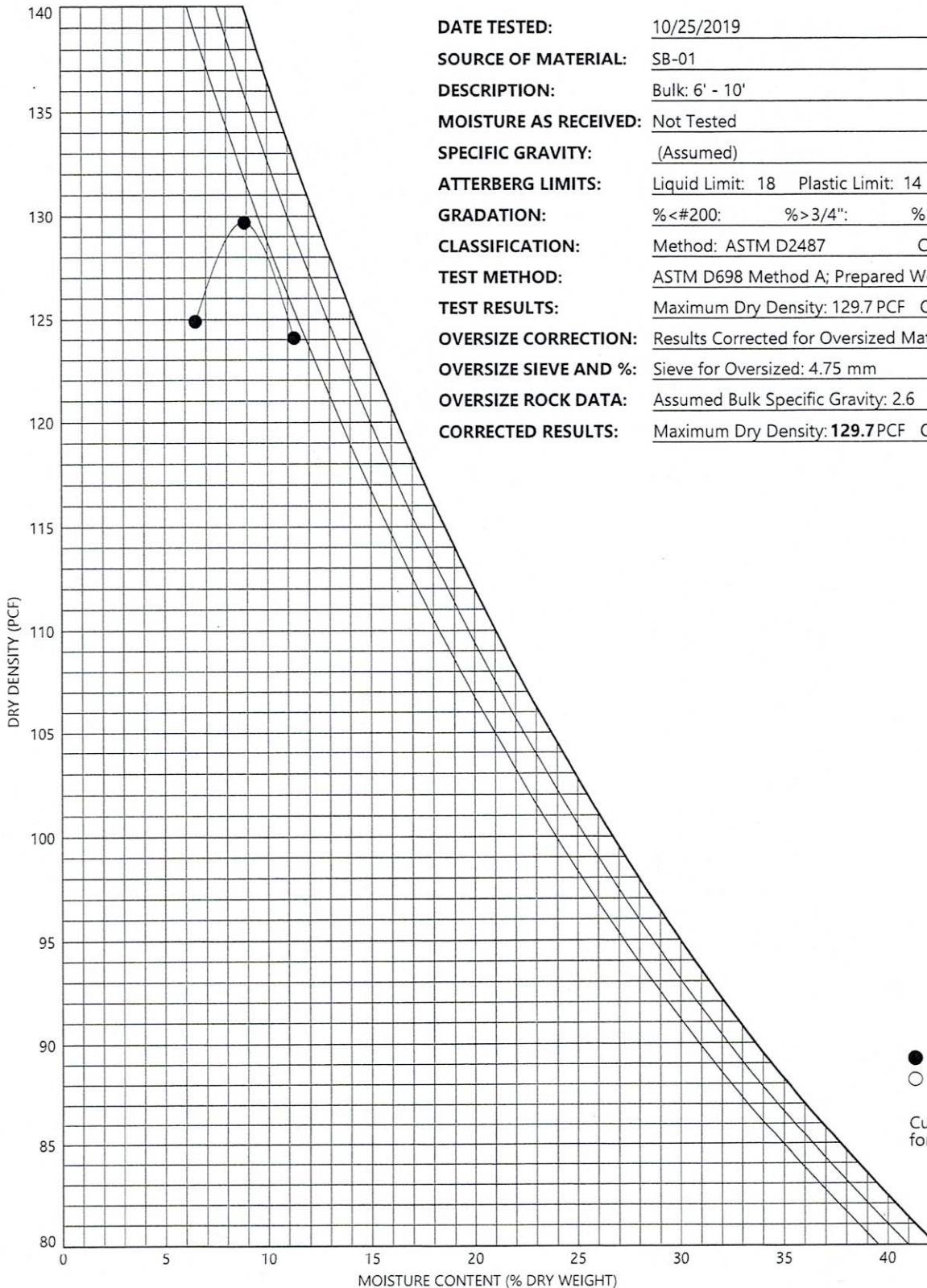

**DATE TESTED:** 10/25/2019

**SOURCE OF MATERIAL:** SB-01

**DESCRIPTION:** Bulk: 6' - 10'

**MOISTURE AS RECEIVED:** Not Tested

**SPECIFIC GRAVITY:** (Assumed)

**ATTERBERG LIMITS:** Liquid Limit: 18 Plastic Limit: 14 Plasticity Index: 4

**GRADATION:** % < #200:      % > 3/4":      % > 3/8":      % > #4: 0

**CLASSIFICATION:** Method: ASTM D2487      Classification: SC-5M

**TEST METHOD:** ASTM D698 Method A; Prepared Wet; Manual Hammer

**TEST RESULTS:** Maximum Dry Density: 129.7 PCF      Optimum Moisture: 8.9 %

**OVERSIZE CORRECTION:** Results Corrected for Oversized Material (ASTM D4718)

**OVERSIZE SIEVE AND %:** Sieve for Oversized: 4.75 mm      Percent Oversized: 0.0 %

**OVERSIZE ROCK DATA:** Assumed Bulk Specific Gravity: 2.6      Moisture: 2.0 %

**CORRECTED RESULTS:** Maximum Dry Density: **129.7** PCF      Optimum Moisture: **8.9** %

● With Oversize Correction  
○ No Oversize Correction

Curves of 100% Saturation  
for Specific Gravity Equal to:

2.80  
2.70  
2.60



610 Spring Branch Road  
 Dunn, NC 28334  
 (910) 292-2085

# MOISTURE-DENSITY RELATIONSHIP

Geotechnical, Environmental, and Materials Engineers

**PROJECT NAME** PWC Annexation - Phase V, Area 25

**PROJECT NUMBER** RD190493

**CLIENT** MKR, Inc.

**PROJECT LOCATION** Fayetteville, NC

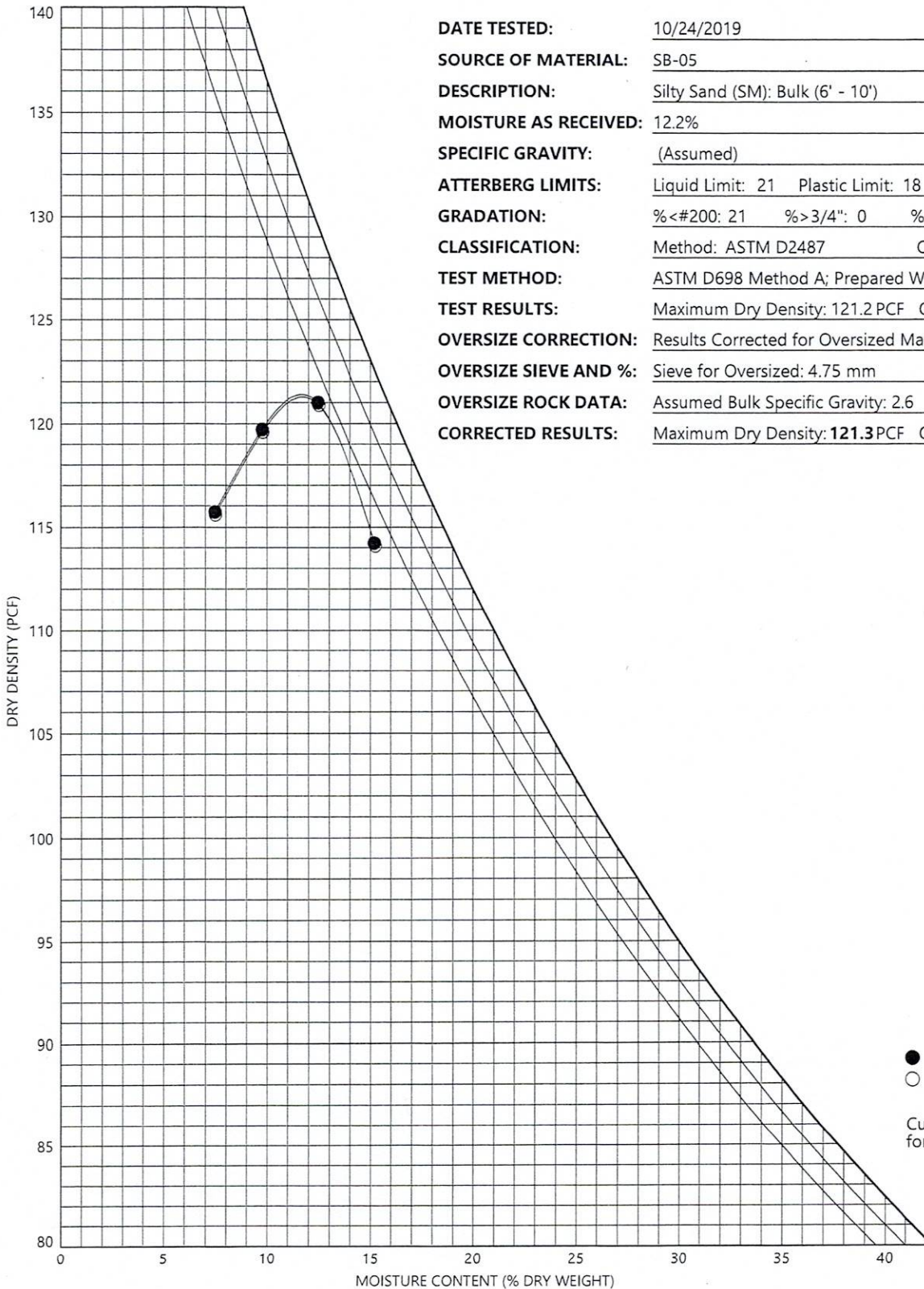

**DATE TESTED:** 10/24/2019

**SOURCE OF MATERIAL:** SB-05

**DESCRIPTION:** Silty Sand (SM): Bulk (6' - 10')

**MOISTURE AS RECEIVED:** 12.2%

**SPECIFIC GRAVITY:** (Assumed)

**ATTERBERG LIMITS:** Liquid Limit: 21 Plastic Limit: 18 Plasticity Index: 3

**GRADATION:** % < #200: 21 % > 3/4": 0 % > 3/8": 0 % > #4: 0

**CLASSIFICATION:** Method: ASTM D2487 Classification: SM

**TEST METHOD:** ASTM D698 Method A; Prepared Wet; Manual Hammer

**TEST RESULTS:** Maximum Dry Density: 121.2 PCF Optimum Moisture: 11.8 %

**OVERSIZE CORRECTION:** Results Corrected for Oversized Material (ASTM D4718)

**OVERSIZE SIEVE AND %:** Sieve for Oversized: 4.75 mm Percent Oversized: 0.4 %

**OVERSIZE ROCK DATA:** Assumed Bulk Specific Gravity: 2.6 Moisture: 2.0 %

**CORRECTED RESULTS:** Maximum Dry Density: 121.3 PCF Optimum Moisture: 11.8 %

● With Oversize Correction  
 ○ No Oversize Correction

Curves of 100% Saturation  
 for Specific Gravity Equal to:

2.80  
 2.70  
 2.60



610 Spring Branch Road  
 Dunn, NC 28334  
 (910) 292-2085

# MOISTURE-DENSITY RELATIONSHIP

Geotechnical, Environmental, and Materials Engineers

**PROJECT NAME** PWC Annexation - Phase V, Area 25

**PROJECT NUMBER** RD190493

**CLIENT** MKR, Inc.

**PROJECT LOCATION** Fayetteville, NC

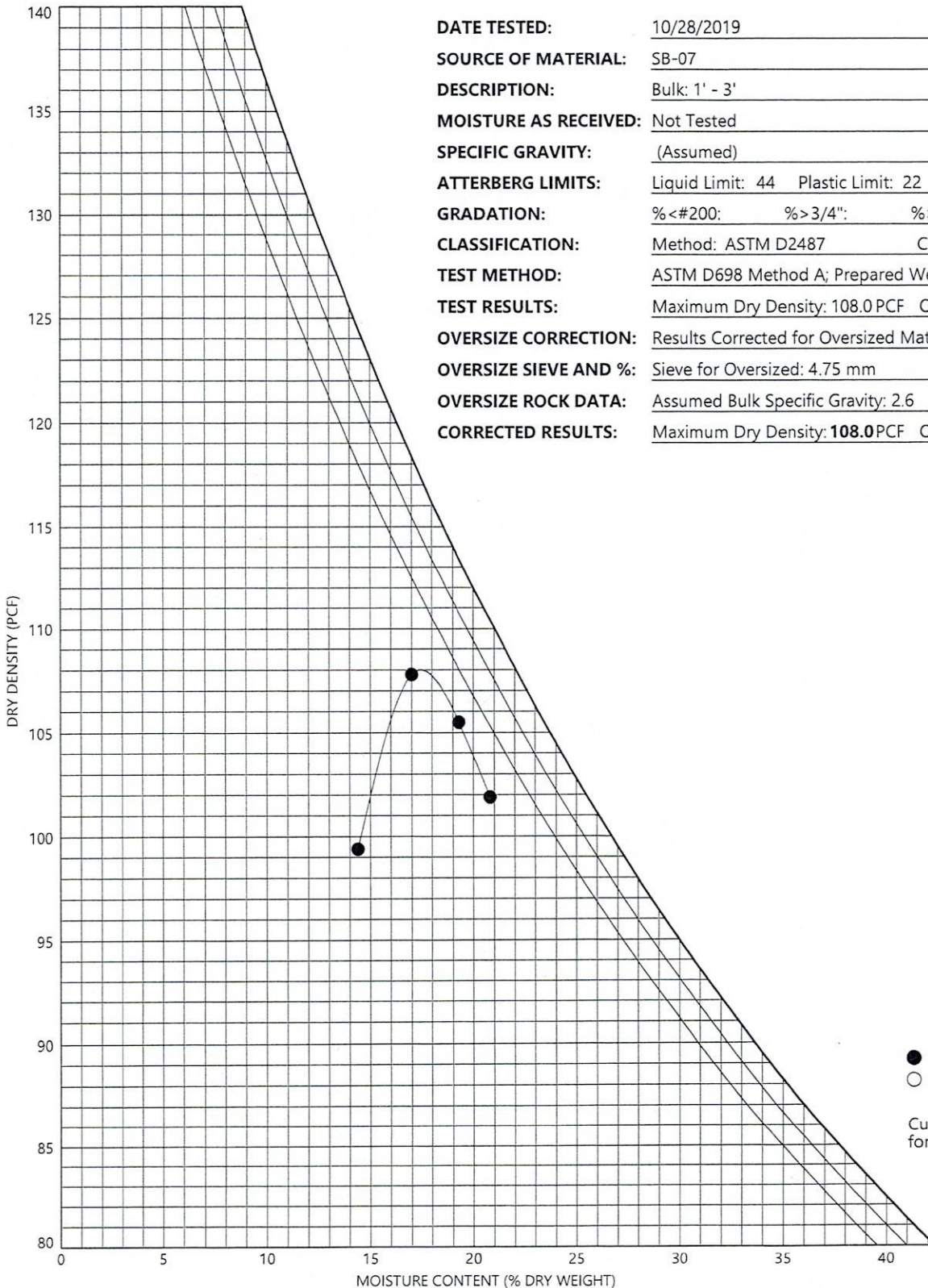

**DATE TESTED:** 10/28/2019

**SOURCE OF MATERIAL:** SB-07

**DESCRIPTION:** Bulk: 1' - 3'

**MOISTURE AS RECEIVED:** Not Tested

**SPECIFIC GRAVITY:** (Assumed)

**ATTERBERG LIMITS:** Liquid Limit: 44 Plastic Limit: 22 Plasticity Index: 22

**GRADATION:** % < #200:      % > 3/4":      % > 3/8":      % > #4: 0

**CLASSIFICATION:** Method: ASTM D2487      Classification: SC

**TEST METHOD:** ASTM D698 Method A; Prepared Wet; Manual Hammer

**TEST RESULTS:** Maximum Dry Density: 108.0 PCF      Optimum Moisture: 17.5 %

**OVERSIZE CORRECTION:** Results Corrected for Oversized Material (ASTM D4718)

**OVERSIZE SIEVE AND %:** Sieve for Oversized: 4.75 mm      Percent Oversized: 0.0 %

**OVERSIZE ROCK DATA:** Assumed Bulk Specific Gravity: 2.6      Moisture: 2.0 %

**CORRECTED RESULTS:** Maximum Dry Density: **108.0** PCF      Optimum Moisture: **17.5** %

● With Oversize Correction  
 ○ No Oversize Correction

Curves of 100% Saturation  
 for Specific Gravity Equal to:  
 2.80  
 2.70  
 2.60



610 Spring Branch Road  
 Dunn, NC 28334  
 (910) 292-2085

# MOISTURE-DENSITY RELATIONSHIP

Geotechnical, Environmental, and Materials Engineers

**PROJECT NAME** PWC Annexation - Phase V, Area 25

**PROJECT NUMBER** RD190493

**CLIENT** MKR, Inc.

**PROJECT LOCATION** Fayetteville, NC

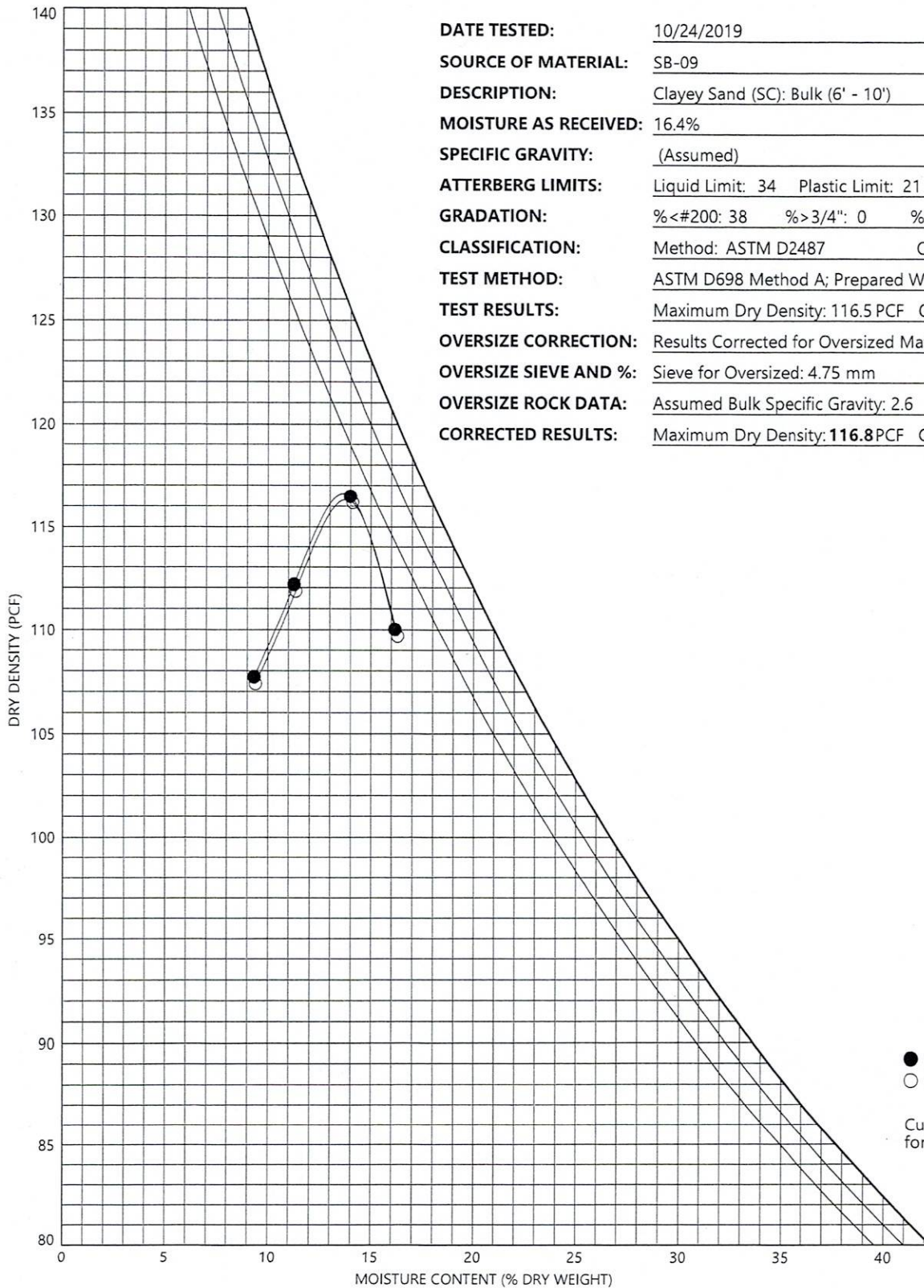

**DATE TESTED:** 10/24/2019

**SOURCE OF MATERIAL:** SB-09

**DESCRIPTION:** Clayey Sand (SC): Bulk (6' - 10')

**MOISTURE AS RECEIVED:** 16.4%

**SPECIFIC GRAVITY:** (Assumed)

**ATTERBERG LIMITS:** Liquid Limit: 34 Plastic Limit: 21 Plasticity Index: 13

**GRADATION:** % < #200: 38 % > 3/4": 0 % > 3/8": 0 % > #4: 1

**CLASSIFICATION:** Method: ASTM D2487 Classification: SC

**TEST METHOD:** ASTM D698 Method A; Prepared Wet; Manual Hammer

**TEST RESULTS:** Maximum Dry Density: 116.5 PCF Optimum Moisture: 13.8 %

**OVERSIZE CORRECTION:** Results Corrected for Oversized Material (ASTM D4718)

**OVERSIZE SIEVE AND %:** Sieve for Oversized: 4.75 mm Percent Oversized: 0.9 %

**OVERSIZE ROCK DATA:** Assumed Bulk Specific Gravity: 2.6 Moisture: 2.0 %

**CORRECTED RESULTS:** Maximum Dry Density: **116.8** PCF Optimum Moisture: **13.7** %

● With Oversize Correction  
 ○ No Oversize Correction

Curves of 100% Saturation for Specific Gravity Equal to:

2.80  
 2.70  
 2.60



610 Spring Branch Road  
 Dunn, NC 28334  
 (910) 292-2085

# MOISTURE-DENSITY RELATIONSHIP

Geotechnical, Environmental, and Materials Engineers

**PROJECT NAME** PWC Annexation - Phase V, Area 25

**PROJECT NUMBER** RD190493

**CLIENT** MKR, Inc.

**PROJECT LOCATION** Fayetteville, NC

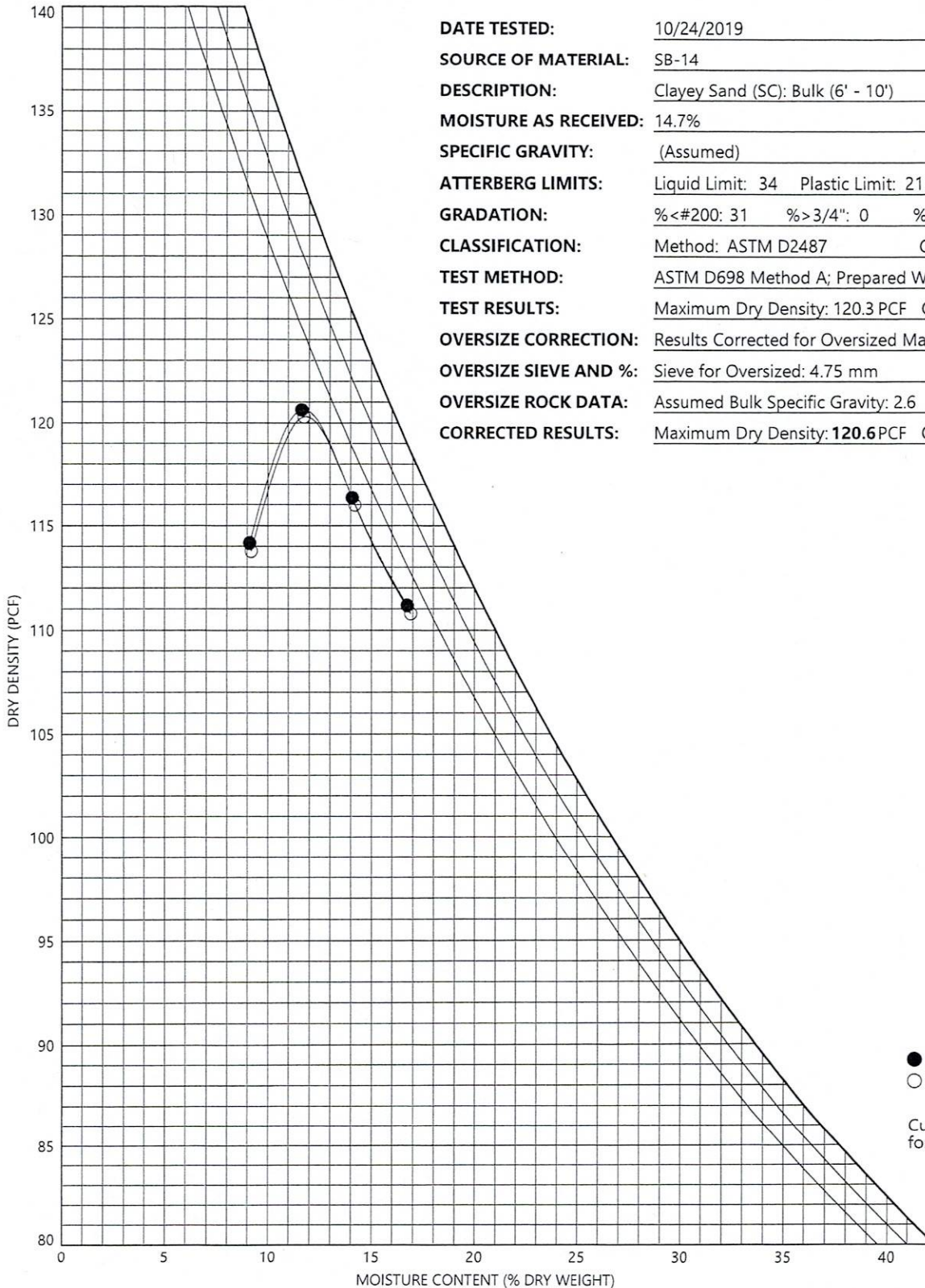

**DATE TESTED:** 10/24/2019

**SOURCE OF MATERIAL:** SB-14

**DESCRIPTION:** Clayey Sand (SC): Bulk (6' - 10')

**MOISTURE AS RECEIVED:** 14.7%

**SPECIFIC GRAVITY:** (Assumed)

**ATTERBERG LIMITS:** Liquid Limit: 34 Plastic Limit: 21 Plasticity Index: 13

**GRADATION:** % <#200: 31 % >3/4": 0 % >3/8": 1 % >#4: 1

**CLASSIFICATION:** Method: ASTM D2487 Classification: SC

**TEST METHOD:** ASTM D698 Method A; Prepared Wet; Manual Hammer

**TEST RESULTS:** Maximum Dry Density: 120.3 PCF Optimum Moisture: 11.9 %

**OVERSIZE CORRECTION:** Results Corrected for Oversized Material (ASTM D4718)

**OVERSIZE SIEVE AND %:** Sieve for Oversized: 4.75 mm Percent Oversized: 1.1 %

**OVERSIZE ROCK DATA:** Assumed Bulk Specific Gravity: 2.6 Moisture: 2.0 %

**CORRECTED RESULTS:** Maximum Dry Density: 120.6 PCF Optimum Moisture: 11.8 %

● With Oversize Correction  
 ○ No Oversize Correction

Curves of 100% Saturation for Specific Gravity Equal to:

2.80  
 2.70  
 2.60





610 Spring Branch Road  
 Dunn, NC 28334  
 (910) 292-2085

# MOISTURE-DENSITY RELATIONSHIP

Geotechnical, Environmental, and Materials Engineers

**PROJECT NAME** PWC Annexation - Phase V, Area 25

**PROJECT NUMBER** RD190493

**CLIENT** MKR, Inc.

**PROJECT LOCATION** Fayetteville, NC

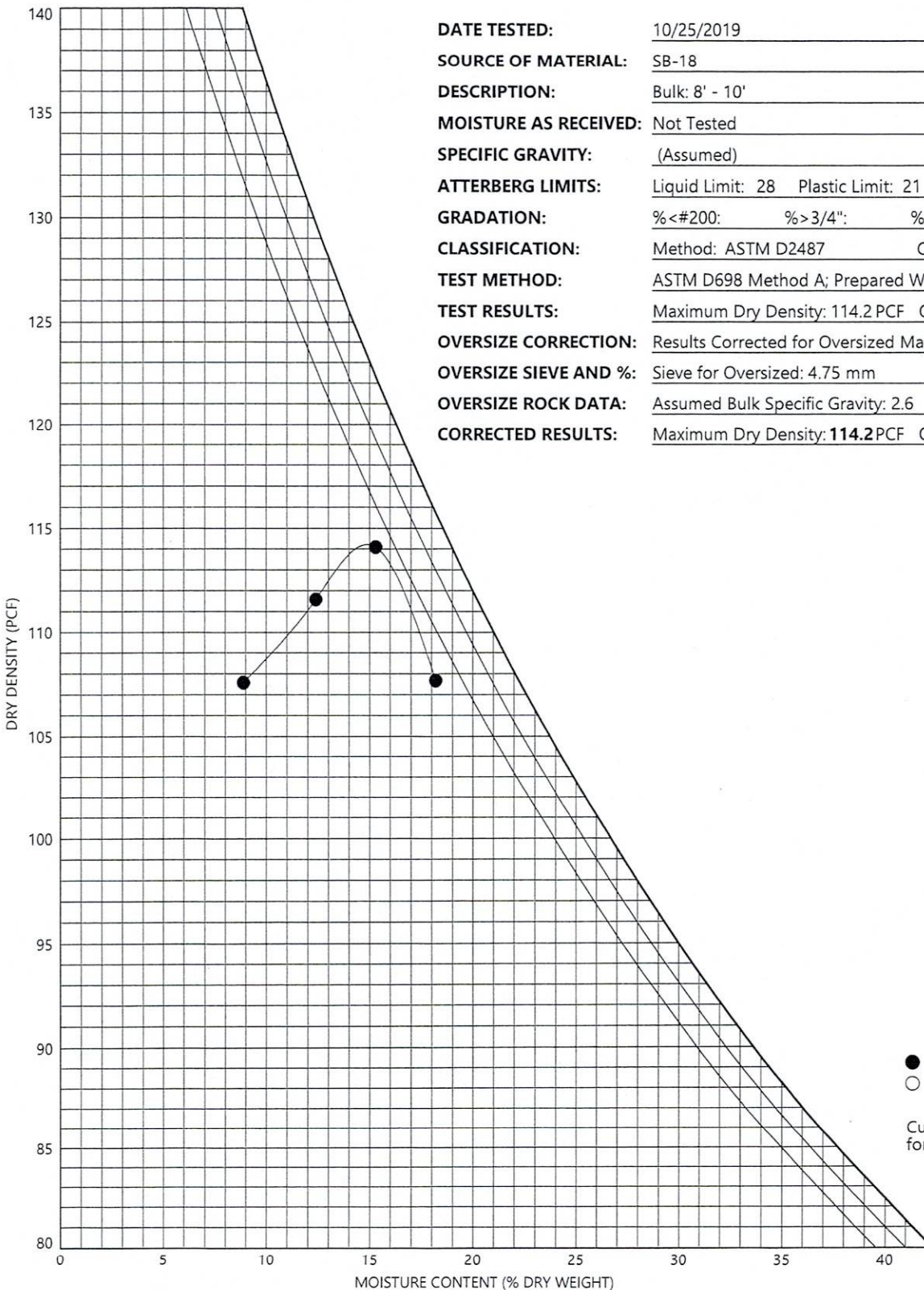

**DATE TESTED:** 10/25/2019

**SOURCE OF MATERIAL:** SB-18

**DESCRIPTION:** Bulk: 8' - 10'

**MOISTURE AS RECEIVED:** Not Tested

**SPECIFIC GRAVITY:** (Assumed)

**ATTERBERG LIMITS:** Liquid Limit: 28 Plastic Limit: 21 Plasticity Index: 7

**GRADATION:** % < #200:            % > 3/4":            % > 3/8":            % > #4: 0

**CLASSIFICATION:** Method: ASTM D2487            Classification: SC-SM

**TEST METHOD:** ASTM D698 Method A; Prepared Wet; Manual Hammer

**TEST RESULTS:** Maximum Dry Density: 114.2 PCF    Optimum Moisture: 14.8 %

**OVERSIZE CORRECTION:** Results Corrected for Oversized Material (ASTM D4718)

**OVERSIZE SIEVE AND %:** Sieve for Oversized: 4.75 mm            Percent Oversized: 0.0 %

**OVERSIZE ROCK DATA:** Assumed Bulk Specific Gravity: 2.6            Moisture: 2.0 %

**CORRECTED RESULTS:** Maximum Dry Density: **114.2** PCF    Optimum Moisture: **14.8** %

● With Oversize Correction  
 ○ No Oversize Correction

Curves of 100% Saturation  
 for Specific Gravity Equal to:

2.80  
 2.70  
 2.60



610 Spring Branch Road  
 Dunn, NC 28334  
 (910) 292-2085

# MOISTURE-DENSITY RELATIONSHIP

Geotechnical, Environmental, and Materials Engineers

**PROJECT NAME** PWC Annexation - Phase V, Area 25

**PROJECT NUMBER** RD190493

**CLIENT** MKR, Inc.

**PROJECT LOCATION** Fayetteville, NC

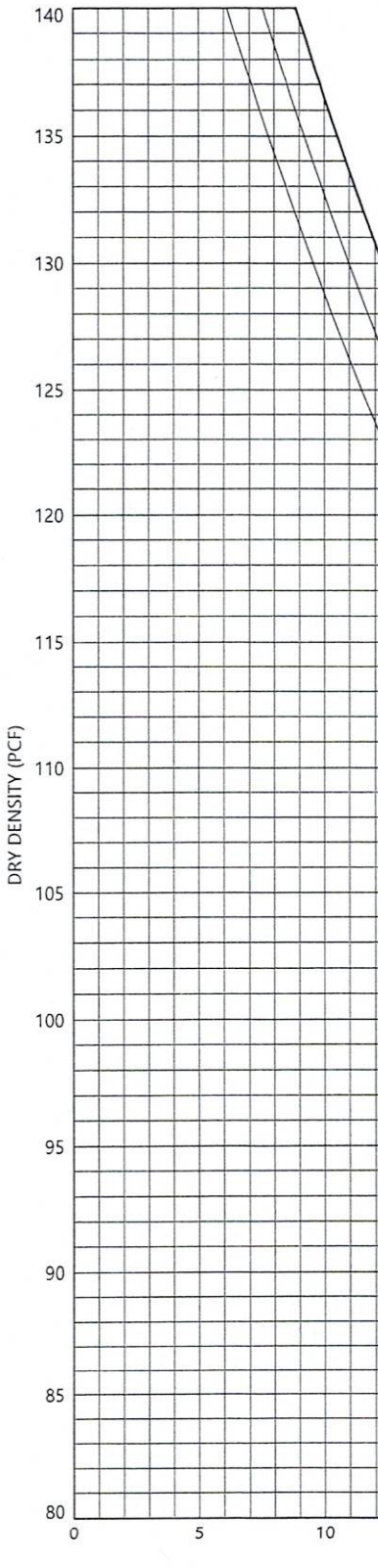

**DATE TESTED:** 10/23/2019

**SOURCE OF MATERIAL:** SB-19

**DESCRIPTION:** Clayey Sand (SC): Bulk (6' - 10')

**MOISTURE AS RECEIVED:** 11.2%

**SPECIFIC GRAVITY:** (Assumed)

**ATTERBERG LIMITS:** Liquid Limit: 46 Plastic Limit: 25 Plasticity Index: 21

**GRADATION:** %<#200: 43 %>3/4": 0 %>3/8": 0 %>#4: 1

**CLASSIFICATION:** Method: ASTM D2487 Classification: SC

**TEST METHOD:** ASTM D698 Method A; Prepared Wet; Manual Hammer

**TEST RESULTS:** Maximum Dry Density: 111.4 PCF Optimum Moisture: 16.4 %

**OVERSIZE CORRECTION:** Results Corrected for Oversized Material (ASTM D4718)

**OVERSIZE SIEVE AND %:** Sieve for Oversized: 4.75 mm Percent Oversized: 0.6 %

**OVERSIZE ROCK DATA:** Assumed Bulk Specific Gravity: 2.6 Moisture: 2.0 %

**CORRECTED RESULTS:** Maximum Dry Density: 111.6 PCF Optimum Moisture: 16.3 %

● With Oversize Correction  
 ○ No Oversize Correction

Curves of 100% Saturation for Specific Gravity Equal to:  
 2.80  
 2.70  
 2.60

Geotechnical, Environmental, and Materials Engineers

**PROJECT NAME** PWC Annexation - Phase V, Area 25

**PROJECT NUMBER** RD190493

**CLIENT** MKR, Inc.

**PROJECT LOCATION** Fayetteville, NC

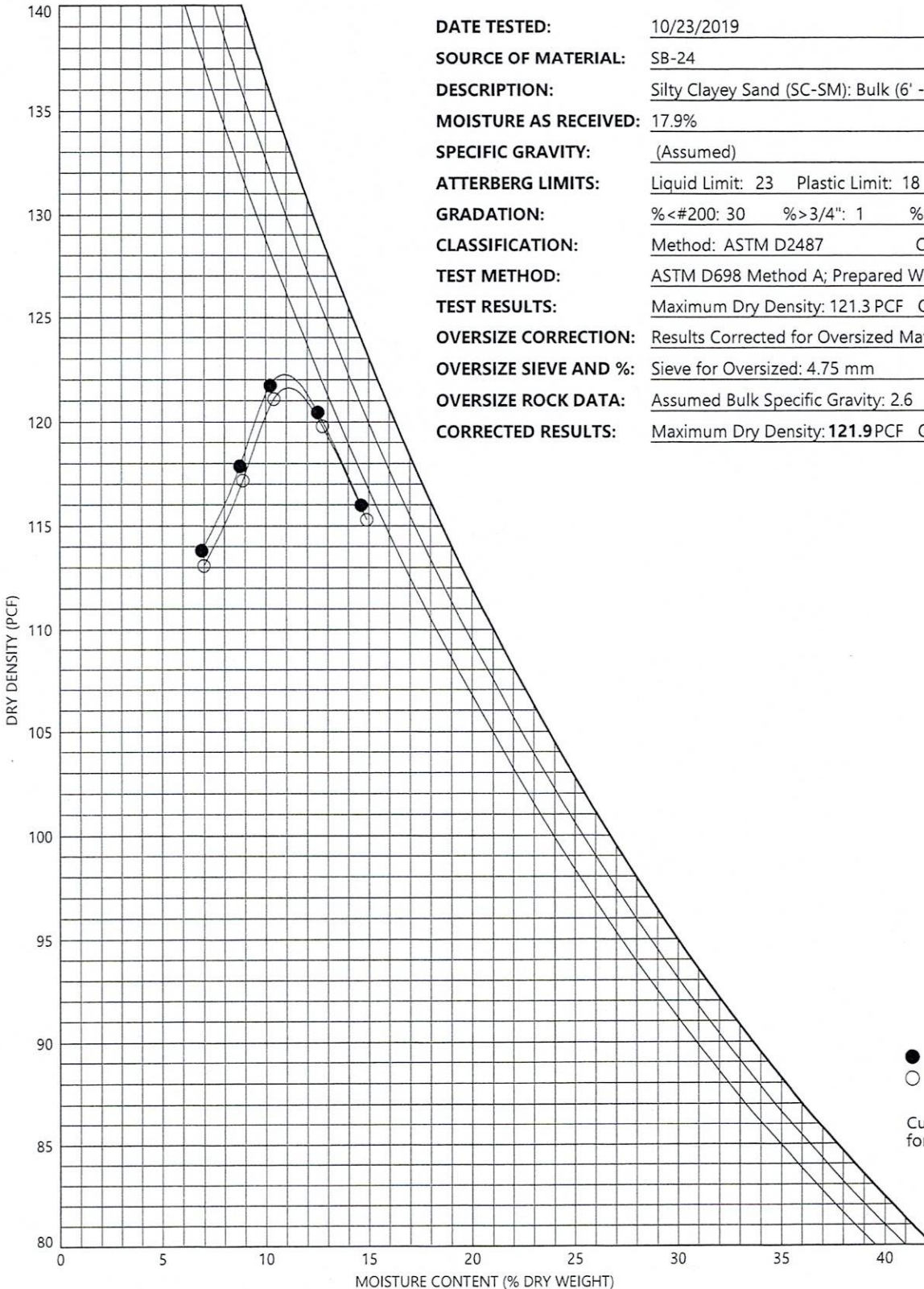

**DATE TESTED:** 10/23/2019

**SOURCE OF MATERIAL:** SB-24

**DESCRIPTION:** Silty Clayey Sand (SC-SM): Bulk (6' - 10')

**MOISTURE AS RECEIVED:** 17.9%

**SPECIFIC GRAVITY:** (Assumed)

**ATTERBERG LIMITS:** Liquid Limit: 23 Plastic Limit: 18 Plasticity Index: 5

**GRADATION:** % < #200: 30 % > 3/4": 1 % > 3/8": 2 % > #4: 2

**CLASSIFICATION:** Method: ASTM D2487 Classification: SC-SM

**TEST METHOD:** ASTM D698 Method A; Prepared Wet; Manual Hammer

**TEST RESULTS:** Maximum Dry Density: 121.3 PCF Optimum Moisture: 11.0 %

**OVERSIZE CORRECTION:** Results Corrected for Oversized Material (ASTM D4718)

**OVERSIZE SIEVE AND %:** Sieve for Oversized: 4.75 mm Percent Oversized: 2.1 %

**OVERSIZE ROCK DATA:** Assumed Bulk Specific Gravity: 2.6 Moisture: 2.0 %

**CORRECTED RESULTS:** Maximum Dry Density: 121.9 PCF Optimum Moisture: 10.8 %

● With Oversize Correction  
○ No Oversize Correction

Curves of 100% Saturation  
for Specific Gravity Equal to:

2.80  
2.70  
2.60

## Soil Test for Corrosion Potential (ANSI/AWWA C105/A21.5 - Appx A)

Project Name: <b>PWC Annexation-Phase V, Area 25</b>	Project Number: <b>RD190493</b>
Client Name: <b>MKR, Inc.</b>	Report Number: <b>1 of 8</b>
Technician: <b>M.Lumpkin</b>	Date: <b>10/29/19</b>

### Testing Data

10 Point Soil-test Evaluation	
Resistivity (ohm-cm)	Points *
< 1,500	10
1,500-1,800	8
1,800-2,100	5
2,100-2,500	2
2,500-3,000	1
>3,000	0
pH	
0-2	5
2-4	3
4-6.5	0
6.5-7.5	0 ‡
7.5-8.5	0
>8.5	3
Redox potential (mV)	
> +100 mV	0
+50 to +100 mV	3.5
0 to +50 mV	4
Negative	5
Sulfides	
Positive	3.5
Trace	2
Negative	0
Moisture	
Poor drainage, continuously wet	2
Fair drainage, generally moist	1
Good drainage, generally dry	0

Soil Sample Location:	<b>SB-07</b>	
Sample Depth/Elevation:	<b>4 - 5 ft</b>	
Soil Description:	<b>SC, Reddish Brown</b>	
Sample Number:	<b>3</b>	
Evaluation Data:		
Test	Results	Point Value
Resistivity (ohm-cm):	6.3 x 100Ω	10
pH:	6.29	0
Redox Potential (mV):	183	0
Sulfides:	trace	2
Moisture:	fair	1
<b>Point Total -</b>	<b>13</b>	

Soil Sample Location:	<b>SB-03</b>	
Sample Depth/Elevation:	<b>3.5 - 5 ft</b>	
Soil Description:	<b>SP, Brown</b>	
Sample Number:	<b>3</b>	
Evaluation Data:		
Test	Results	Point Value
Resistivity (ohm-cm):	8.1 x 100Ω	10
pH:	7.04	0
Redox Potential (mV):	166	0
Sulfides:	negative	0
Moisture:	fair	1
<b>Point Total -</b>	<b>11</b>	

\* A sum of 10 points from all tests indicates that the soil is corrosive to ductile iron pipe

‡ If sulfides are present and low or negative redox-potential results are obtained, add three points to this range.

**Soil Test for Corrosion Potential (ANSI/AWWA C105/A21.5 - Appx A)**

Project Name: PWC Annexation-Phase V, Area 25 Project Number: RD190493  
 Client Name: MKR, Inc. Report Number: 2 of 8  
 Technician: M.Lumpkin Date: 10/29/19

**Testing Data**

10 Point Soil-test Evaluation	
<b>Resistivity (ohm-cm)</b>	Points *
< 1,500	10
1,500-1,800	8
1,800-2,100	5
2,100-2,500	2
2,500-3,000	1
>3,000	0
<b>pH</b>	
0-2	5
2-4	3
4-6.5	0
6.5-7.5	0 ‡
7.5-8.5	0
>8.5	3
<b>Redox potential (mV)</b>	
> +100 mV	0
+50 to +100 mV	3.5
0 to +50 mV	4
Negative	5
<b>Sulfides</b>	
Positive	3.5
Trace	2
Negative	0
<b>Moisture</b>	
Poor drainage, continuously wet	2
Fair drainage, generally moist	1
Good drainage, generally dry	0

Soil Sample Location:	<u>SB-01</u>	
Sample Depth/Elevation:	<u>6 - 7.5 ft</u>	
Soil Description:	<u>SM, Brown</u>	
Sample Number:	<u>4</u>	
<b>Evaluation Data:</b>		
<b>Test</b>	<b>Results</b>	<b>Point Value</b>
Resistivity (ohm-cm):	<u>2.4 x 1kΩ</u>	<u>2</u>
pH:	<u>7.05</u>	<u>0</u>
Redox Potential (mV):	<u>212</u>	<u>0</u>
Sulfides:	<u>positive</u>	<u>3.5</u>
Moisture:	<u>poor</u>	<u>2</u>
<b>Point Total -</b>		<b><u>7.5</u></b>

Soil Sample Location:	<u>SB-01A</u>	
Sample Depth/Elevation:	<u>8.5 - 10 ft</u>	
Soil Description:	<u>SC, Reddish Brown</u>	
Sample Number:	<u>5</u>	
<b>Evaluation Data:</b>		
<b>Test</b>	<b>Results</b>	<b>Point Value</b>
Resistivity (ohm-cm):	<u>7.7 x 100Ω</u>	<u>10</u>
pH:	<u>6.99</u>	<u>0</u>
Redox Potential (mV):	<u>302</u>	<u>0</u>
Sulfides:	<u>trace</u>	<u>2</u>
Moisture:	<u>good</u>	<u>0</u>
<b>Point Total -</b>		<b><u>12</u></b>

\* A sum of 10 points from all tests indicates that the soil is corrosive to ductile iron pipe

‡ If sulfides are present and low or negative redox-potential results are obtained, add three points to this range.

## Soil Test for Corrosion Potential (ANSI/AWWA C105/A21.5 - Appx A)

Project Name: <b>PWC Annexation-Phase V, Area 25</b>	Project Number: <b>RD190493</b>
Client Name: <b>MKR, Inc.</b>	Report Number: <b>3 of 8</b>
Technician: <b>M.Lumpkin</b>	Date: <b>10/29/19</b>

### Testing Data

10 Point Soil-test Evaluation	
Resistivity (ohm-cm)	Points *
< 1,500	10
1,500-1,800	8
1,800-2,100	5
2,100-2,500	2
2,500-3,000	1
>3,000	0
pH	Points
0-2	5
2-4	3
4-6.5	0
6.5-7.5	0 ‡
7.5-8.5	0
>8.5	3
Redox potential (mV)	Points
> +100 mV	0
+50 to +100 mV	3.5
0 to +50 mV	4
Negative	5
Sulfides	Points
Positive	3.5
Trace	2
Negative	0
Moisture	Points
Poor drainage, continuously wet	2
Fair drainage, generally moist	1
Good drainage, generally dry	0

Soil Sample Location:	<b>SB-04</b>	
Sample Depth/Elevation:	<b>6 - 7.5 ft</b>	
Soil Description:	<b>SC, Brown</b>	
Sample Number:	<b>4</b>	
Evaluation Data:		
Test	Results	Point Value
Resistivity (ohm-cm):	8.9 x 100Ω	10
pH:	6.80	0
Redox Potential (mV):	297	0
Sulfides:	trace	2
Moisture:	fair	1
<b>Point Total -</b>		<b>13</b>

Soil Sample Location:	<b>SB-22</b>	
Sample Depth/Elevation:	<b>6 - 7.5 ft</b>	
Soil Description:	<b>SC, Reddish Brown</b>	
Sample Number:	<b>4</b>	
Evaluation Data:		
Test	Results	Point Value
Resistivity (ohm-cm):	6.5 x 10kΩ	0
pH:	5.20	0
Redox Potential (mV):	227	0
Sulfides:	positive	3.5
Moisture:	fair	1
<b>Point Total -</b>		<b>4.5</b>

\* A sum of 10 points from all tests indicates that the soil is corrosive to ductile iron pipe

‡ If sulfides are present and low or negative redox-potential results are obtained, add three points to this range.

## Soil Test for Corrosion Potential (ANSI/AWWA C105/A21.5 - Appx A)

Project Name: <b>PWC Annexation-Phase V, Area 25</b>	Project Number: <b>RD190493</b>
Client Name: <b>MKR, Inc.</b>	Report Number: <b>4 of 8</b>
Technician: <b>M.Lumpkin</b>	Date: <b>10/29/19</b>

### Testing Data

10 Point Soil-test Evaluation	
Resistivity (ohm-cm)	Points *
< 1,500	10
1,500-1,800	8
1,800-2,100	5
2,100-2,500	2
2,500-3,000	1
>3,000	0
pH	
0-2	5
2-4	3
4-6.5	0
6.5-7.5	0 ‡
7.5-8.5	0
>8.5	3
Redox potential (mV)	
> +100 mV	0
+50 to +100 mV	3.5
0 to +50 mV	4
Negative	5
Sulfides	
Positive	3.5
Trace	2
Negative	0
Moisture	
Poor drainage, continuously wet	2
Fair drainage, generally moist	1
Good drainage, generally dry	0

Soil Sample Location:	<b>HA -04</b>	
Sample Depth/Elevation:	<b>3 - 4 ft</b>	
Soil Description:	<b>SC, Reddish Brown</b>	
Sample Number:	<b>3</b>	
Evaluation Data:		
Test	Results	Point Value
Resistivity (ohm-cm):	6.2 x 100Ω	10
pH:	6.82	0
Redox Potential (mV):	281	0
Sulfides:	positive	3.5
Moisture:	fair	1
<b>Point Total -</b>	<b>14.5</b>	

Soil Sample Location:	<b>HA - 05</b>	
Sample Depth/Elevation:	<b>4 - 5 ft</b>	
Soil Description:	<b>SC, Reddish Gray</b>	
Sample Number:	<b>4</b>	
Evaluation Data:		
Test	Results	Point Value
Resistivity (ohm-cm):	6.0 x 10kΩ	0
pH:	5.20	0
Redox Potential (mV):	225	0
Sulfides:	trace	2
Moisture:	fair	1
<b>Point Total -</b>	<b>3</b>	

\* A sum of 10 points from all tests indicates that the soil is corrosive to ductile iron pipe

‡ If sulfides are present and low or negative redox-potential results are obtained, add three points to this range.

## Soil Test for Corrosion Potential (ANSI/AWWA C105/A21.5 - Appx A)

Project Name: <b>PWC Annexation-Phase V, Area 25</b>	Project Number: <b>RD190493</b>
Client Name: <b>MKR, Inc.</b>	Report Number: <b>5 of 8</b>
Technician: <b>M.Lumpkin</b>	Date: <b>10/31/19</b>

### Testing Data

10 Point Soil-test Evaluation	
Resistivity (ohm-cm)	Points *
< 1,500	10
1,500-1,800	8
1,800-2,100	5
2,100-2,500	2
2,500-3,000	1
>3,000	0
pH	
0-2	5
2-4	3
4-6.5	0
6.5-7.5	0 ‡
7.5-8.5	0
>8.5	3
Redox potential (mV)	
> +100 mV	0
+50 to +100 mV	3.5
0 to +50 mV	4
Negative	5
Sulfides	
Positive	3.5
Trace	2
Negative	0
Moisture	
Poor drainage, continuously wet	2
Fair drainage, generally moist	1
Good drainage, generally dry	0

Soil Sample Location:	<b>HA - 11</b>	
Sample Depth/Elevation:	<b>7 - 8 ft</b>	
Soil Description:	<b>SM, Brown</b>	
Sample Number:	<b>4</b>	
Evaluation Data:		
Test	Results	Point Value
Resistivity (ohm-cm):	4.4 x 10kΩ	0
pH:	5.68	0
Redox Potential (mV):	235	0
Sulfides:	negative	0
Moisture:	poor	2
<b>Point Total -</b>		<b>2</b>

Soil Sample Location:	<b>HA - 12</b>	
Sample Depth/Elevation:	<b>5 - 6 ft</b>	
Soil Description:	<b>SC, Light Brown</b>	
Sample Number:	<b>4</b>	
Evaluation Data:		
Test	Results	Point Value
Resistivity (ohm-cm):	2.5 x 10kΩ	0
pH:	6.54	0
Redox Potential (mV):	227	0
Sulfides:	trace	2
Moisture:	fair	1
<b>Point Total -</b>		<b>3</b>

\* A sum of 10 points from all tests indicates that the soil is corrosive to ductile iron pipe

‡ If sulfides are present and low or negative redox-potential results are obtained, add three points to this range.



## Soil Test for Corrosion Potential (ANSI/AWWA C105/A21.5 - Appx A)

Project Name: <b>PWC Annexation-Phase V, Area 25</b>	Project Number: <b>RD190493</b>
Client Name: <b>MKR, Inc.</b>	Report Number: <b>6 of 8</b>
Technician: <b>M.Lumpkin</b>	Date: <b>10/31/19</b>

### Testing Data

10 Point Soil-test Evaluation	
Resistivity (ohm-cm)	Points *
< 1,500	10
1,500-1,800	8
1,800-2,100	5
2,100-2,500	2
2,500-3,000	1
>3,000	0
pH	
0-2	5
2-4	3
4-6.5	0
6.5-7.5	0 ‡
7.5-8.5	0
>8.5	3
Redox potential (mV)	
> +100 mV	0
+50 to +100 mV	3.5
0 to +50 mV	4
Negative	5
Sulfides	
Positive	3.5
Trace	2
Negative	0
Moisture	
Poor drainage, continuously wet	2
Fair drainage, generally moist	1
Good drainage, generally dry	0

Soil Sample Location:	<b>HA - 01</b>	
Sample Depth/Elevation:	<b>5 - 6 ft</b>	
Soil Description:	<b>SC, Dark Reddish Brown</b>	
Sample Number:	<b>4</b>	
Evaluation Data:		
Test	Results	Point Value
Resistivity (ohm-cm):	6.1 x 10kΩ	0
pH:	5.88	0
Redox Potential (mV):	289	0
Sulfides:	positive	3.5
Moisture:	good	0
<b>Point Total -</b>	<b>3.5</b>	

Soil Sample Location:	<b>HA - 02</b>	
Sample Depth/Elevation:	<b>6 - 7 ft</b>	
Soil Description:	<b>SC, Reddish Brown</b>	
Sample Number:	<b>4</b>	
Evaluation Data:		
Test	Results	Point Value
Resistivity (ohm-cm):	8.0 x 10kΩ	0
pH:	5.64	0
Redox Potential (mV):	296	0
Sulfides:	positive	3.5
Moisture:	fair	1
<b>Point Total -</b>	<b>4.5</b>	

\* A sum of 10 points from all tests indicates that the soil is corrosive to ductile iron pipe

‡ If sulfides are present and low or negative redox-potential results are obtained, add three points to this range.

**Soil Test for Corrosion Potential (ANSI/AWWA C105/A21.5 - Appx A)**

Project Name: PWC Annexation-Phase V, Area 25 Project Number: RD190493  
 Client Name: MKR, Inc. Report Number: 7 of 8  
 Technician: M.Lumpkin Date: 10/31/19

**Testing Data**

10 Point Soil-test Evaluation	
Resistivity (ohm-cm)	Points *
< 1,500	10
1,500-1,800	8
1,800-2,100	5
2,100-2,500	2
2,500-3,000	1
>3,000	0
<b>pH</b>	
0-2	5
2-4	3
4-6.5	0
6.5-7.5	0 ‡
7.5-8.5	0
>8.5	3
<b>Redox potential (mV)</b>	
> +100 mV	0
+50 to +100 mV	3.5
0 to +50 mV	4
Negative	5
<b>Sulfides</b>	
Positive	3.5
Trace	2
Negative	0
<b>Moisture</b>	
Poor drainage, continuously wet	2
Fair drainage, generally moist	1
Good drainage, generally dry	0

Soil Sample Location:	<u>HA - 03</u>	
Sample Depth/Elevation:	<u>4 - 5 ft</u>	
Soil Description:	<u>SC, Reddish Brown</u>	
Sample Number:	<u>3</u>	
<b>Evaluation Data:</b>		
Test	Results	Point Value
Resistivity (ohm-cm):	<u>8.3 x 10kΩ</u>	<u>0</u>
pH:	<u>5.63</u>	<u>0</u>
Redox Potential (mV):	<u>273</u>	<u>0</u>
Sulfides:	<u>positive</u>	<u>3.5</u>
Moisture:	<u>fair</u>	<u>1</u>
<b>Point Total -</b>		<b>4.5</b>

Soil Sample Location:	<u>HA - 06</u>	
Sample Depth/Elevation:	<u>5 - 6 ft</u>	
Soil Description:	<u>SC, Dark Reddish Brown</u>	
Sample Number:	<u>4</u>	
<b>Evaluation Data:</b>		
Test	Results	Point Value
Resistivity (ohm-cm):	<u>1.5 x 100kΩ</u>	<u>0</u>
pH:	<u>5.76</u>	<u>0</u>
Redox Potential (mV):	<u>294</u>	<u>0</u>
Sulfides:	<u>positive</u>	<u>3.5</u>
Moisture:	<u>fair</u>	<u>1</u>
<b>Point Total -</b>		<b>4.5</b>

\* A sum of 10 points from all tests indicates that the soil is corrosive to ductile iron pipe

‡ If sulfides are present and low or negative redox-potential results are obtained, add three points to this range.

## Soil Test for Corrosion Potential (ANSI/AWWA C105/A21.5 - Appx A)

Project Name: <b>PWC Annexation-Phase V, Area 25</b>	Project Number: <b>RD190493</b>
Client Name: <b>MKR, Inc.</b>	Report Number: <b>8 of 8</b>
Technician: <b>M.Lumpkin</b>	Date: <b>10/31/19</b>

### Testing Data

10 Point Soil-test Evaluation	
Resistivity (ohm-cm)	Points *
< 1,500	10
1,500-1,800	8
1,800-2,100	5
2,100-2,500	2
2,500-3,000	1
>3,000	0
pH	
0-2	5
2-4	3
4-6.5	0
6.5-7.5	0 ‡
7.5-8.5	0
>8.5	3
Redox potential (mV)	
> +100 mV	0
+50 to +100 mV	3.5
0 to +50 mV	4
Negative	5
Sulfides	
Positive	3.5
Trace	2
Negative	0
Moisture	
Poor drainage, continuously wet	2
Fair drainage, generally moist	1
Good drainage, generally dry	0

Soil Sample Location:	<b>HA - 07</b>	
Sample Depth/Elevation:	<b>5 - 6 ft</b>	
Soil Description:	<b>SM, Reddish Brown</b>	
Sample Number:	<b>4</b>	
Evaluation Data:		
Test	Results	Point Value
Resistivity (ohm-cm):	4.3 x 10kΩ	0
pH:	6.20	0
Redox Potential (mV):	257	0
Sulfides:	negative	0
Moisture:	poor	2
<b>Point Total -</b>		<b>2</b>

Soil Sample Location:	<b>HA - 09</b>	
Sample Depth/Elevation:	<b>5 - 6 ft</b>	
Soil Description:	<b>SC, Brown</b>	
Sample Number:	<b>4</b>	
Evaluation Data:		
Test	Results	Point Value
Resistivity (ohm-cm):	6.5 x 10kΩ	0
pH:	6.04	0
Redox Potential (mV):	300	0
Sulfides:	trace	2
Moisture:	poor	2
<b>Point Total -</b>		<b>4</b>

\* A sum of 10 points from all tests indicates that the soil is corrosive to ductile iron pipe

‡ If sulfides are present and low or negative redox-potential results are obtained, add three points to this range.

## Important Information about This

# Geotechnical-Engineering Report

**Subsurface problems are a principal cause of construction delays, cost overruns, claims, and disputes.**

**While you cannot eliminate all such risks, you can manage them. The following information is provided to help.**

### **Geotechnical Services Are Performed for Specific Purposes, Persons, and Projects**

Geotechnical engineers structure their services to meet the specific needs of their clients. A geotechnical-engineering study conducted for a civil engineer may not fulfill the needs of a constructor — a construction contractor — or even another civil engineer. Because each geotechnical-engineering study is unique, each geotechnical-engineering report is unique, prepared *solely* for the client. No one except you should rely on this geotechnical-engineering report without first conferring with the geotechnical engineer who prepared it. *And no one — not even you — should apply this report for any purpose or project except the one originally contemplated.*

### **Read the Full Report**

Serious problems have occurred because those relying on a geotechnical-engineering report did not read it all. Do not rely on an executive summary. Do not read selected elements only.

### **Geotechnical Engineers Base Each Report on a Unique Set of Project-Specific Factors**

Geotechnical engineers consider many unique, project-specific factors when establishing the scope of a study. Typical factors include: the client's goals, objectives, and risk-management preferences; the general nature of the structure involved, its size, and configuration; the location of the structure on the site; and other planned or existing site improvements, such as access roads, parking lots, and underground utilities. Unless the geotechnical engineer who conducted the study specifically indicates otherwise, do not rely on a geotechnical-engineering report that was:

- not prepared for you;
- not prepared for your project;
- not prepared for the specific site explored; or
- completed before important project changes were made.

Typical changes that can erode the reliability of an existing geotechnical-engineering report include those that affect:

- the function of the proposed structure, as when it's changed from a parking garage to an office building, or from a light-industrial plant to a refrigerated warehouse;
- the elevation, configuration, location, orientation, or weight of the proposed structure;
- the composition of the design team; or
- project ownership.

As a general rule, *always* inform your geotechnical engineer of project changes—even minor ones—and request an

assessment of their impact. *Geotechnical engineers cannot accept responsibility or liability for problems that occur because their reports do not consider developments of which they were not informed.*

### **Subsurface Conditions Can Change**

A geotechnical-engineering report is based on conditions that existed at the time the geotechnical engineer performed the study. *Do not rely on a geotechnical-engineering report whose adequacy may have been affected by:* the passage of time; man-made events, such as construction on or adjacent to the site; or natural events, such as floods, droughts, earthquakes, or groundwater fluctuations. *Contact the geotechnical engineer before applying this report to determine if it is still reliable.* A minor amount of additional testing or analysis could prevent major problems.

### **Most Geotechnical Findings Are Professional Opinions**

Site exploration identifies subsurface conditions only at those points where subsurface tests are conducted or samples are taken. Geotechnical engineers review field and laboratory data and then apply their professional judgment to render an opinion about subsurface conditions throughout the site. Actual subsurface conditions may differ — sometimes significantly — from those indicated in your report. Retaining the geotechnical engineer who developed your report to provide geotechnical-construction observation is the most effective method of managing the risks associated with unanticipated conditions.

### **A Report's Recommendations Are Not Final**

Do not overrely on the confirmation-dependent recommendations included in your report. *Confirmation-dependent recommendations are not final,* because geotechnical engineers develop them principally from judgment and opinion. Geotechnical engineers can finalize their recommendations *only* by observing actual subsurface conditions revealed during construction. *The geotechnical engineer who developed your report cannot assume responsibility or liability for the report's confirmation-dependent recommendations if that engineer does not perform the geotechnical-construction observation required to confirm the recommendations' applicability.*

### **A Geotechnical-Engineering Report Is Subject to Misinterpretation**

Other design-team members' misinterpretation of geotechnical-engineering reports has resulted in costly

problems. Confront that risk by having your geotechnical engineer confer with appropriate members of the design team after submitting the report. Also retain your geotechnical engineer to review pertinent elements of the design team's plans and specifications. Constructors can also misinterpret a geotechnical-engineering report. Confront that risk by having your geotechnical engineer participate in prebid and preconstruction conferences, and by providing geotechnical construction observation.

### **Do Not Redraw the Engineer's Logs**

Geotechnical engineers prepare final boring and testing logs based upon their interpretation of field logs and laboratory data. To prevent errors or omissions, the logs included in a geotechnical-engineering report should *never* be redrawn for inclusion in architectural or other design drawings. Only photographic or electronic reproduction is acceptable, *but recognize that separating logs from the report can elevate risk.*

### **Give Constructors a Complete Report and Guidance**

Some owners and design professionals mistakenly believe they can make constructors liable for unanticipated subsurface conditions by limiting what they provide for bid preparation. To help prevent costly problems, give constructors the complete geotechnical-engineering report, *but* preface it with a clearly written letter of transmittal. In that letter, advise constructors that the report was not prepared for purposes of bid development and that the report's accuracy is limited; encourage them to confer with the geotechnical engineer who prepared the report (a modest fee may be required) and/or to conduct additional study to obtain the specific types of information they need or prefer. A prebid conference can also be valuable. *Be sure constructors have sufficient time to perform additional study. Only then might you be in a position to give constructors the best information available to you, while requiring them to at least share some of the financial responsibilities stemming from unanticipated conditions.*

### **Read Responsibility Provisions Closely**

Some clients, design professionals, and constructors fail to recognize that geotechnical engineering is far less exact than other engineering disciplines. This lack of understanding has created unrealistic expectations that have led to disappointments, claims, and disputes. To help reduce the risk of such outcomes, geotechnical engineers commonly include a variety of explanatory provisions in their reports. Sometimes labeled "limitations," many of these provisions indicate where geotechnical engineers' responsibilities begin and end, to help

others recognize their own responsibilities and risks. *Read these provisions closely. Ask questions. Your geotechnical engineer should respond fully and frankly.*

### **Environmental Concerns Are Not Covered**

The equipment, techniques, and personnel used to perform an *environmental* study differ significantly from those used to perform a *geotechnical* study. For that reason, a geotechnical-engineering report does not usually relate any environmental findings, conclusions, or recommendations; e.g., about the likelihood of encountering underground storage tanks or regulated contaminants. *Unanticipated environmental problems have led to numerous project failures.* If you have not yet obtained your own environmental information, ask your geotechnical consultant for risk-management guidance. *Do not rely on an environmental report prepared for someone else.*

### **Obtain Professional Assistance To Deal with Mold**

Diverse strategies can be applied during building design, construction, operation, and maintenance to prevent significant amounts of mold from growing on indoor surfaces. To be effective, all such strategies should be devised for the *express purpose* of mold prevention, integrated into a comprehensive plan, and executed with diligent oversight by a professional mold-prevention consultant. Because just a small amount of water or moisture can lead to the development of severe mold infestations, many mold-prevention strategies focus on keeping building surfaces dry. While groundwater, water infiltration, and similar issues may have been addressed as part of the geotechnical-engineering study whose findings are conveyed in this report, the geotechnical engineer in charge of this project is not a mold prevention consultant; *none of the services performed in connection with the geotechnical engineer's study were designed or conducted for the purpose of mold prevention. Proper implementation of the recommendations conveyed in this report will not of itself be sufficient to prevent mold from growing in or on the structure involved.*

### **Rely, on Your GBC-Member Geotechnical Engineer for Additional Assistance**

Membership in the Geotechnical Business Council of the Geoprofessional Business Association exposes geotechnical engineers to a wide array of risk-confrontation techniques that can be of genuine benefit for everyone involved with a construction project. Confer with your GBC-Member geotechnical engineer for more information.



8811 Colesville Road/Suite G106, Silver Spring, MD 20910  
Telephone: 301/565-2733 Facsimile: 301/589-2017  
e-mail: info@geoprofessional.org www.geoprofessional.org

Copyright 2015 by Geoprofessional Business Association (GBC). Duplication, reproduction, or copying of this document, or its contents, in whole or in part, by any means whatsoever, is strictly prohibited, except with GBA's specific written permission. Excerpting, quoting, or otherwise extracting wording from this document is permitted only with the express written permission of GBA, and only for purposes of scholarly research or book review. Only members of GBA may use this document as a complement to or as an element of a geotechnical-engineering report. Any other firm, individual, or other entity that so uses this document without being a GBA member could be committing negligent or intentional (fraudulent) misrepresentation.

# **APPENDIX D – EROSION AND SEDIMENTATION CONTROL NARRATIVE**

**FAYETTEVILLE ANNEXATION PHASE V, PROJECT IX, CONSTRUCTION AREA  
25 LAKE RIM ESTATES AND OAK MEADOW SUBDIVISION**

**EROSION AND SEDIMENTATION CONTROL NARRATIVE**

**June 2022**

**PROJECT DESCRIPTION**

The purpose of this project is to provide sanitary sewer service to Lake Rim Estates and Oak Meadow Subdivision generally east and west of Rim Rd. between Mountain Home Dr. and Oak Meadow Court. Both Subdivisions have existing paved streets, municipal and private utilities except public sanitary sewer. The project is located in Fayetteville, NC. The surrounding areas are developed to the north, east and west and large tracts of woodlands sparsely developed along the northern edge of Lake Rim. The project is planned to begin construction October 2022 and will have a construction period of 530 days ending in June 2023. The project will extend 8" and 12" sanitary sewer within street right-of-ways and easements and 8" and 12" water within street R/W and easements. Disturbed area is 17.12 Ac.

**SITE DESCRIPTION**

The site is within the fully developed subdivisions of Lake Rim Estates and Oak Meadow Subdivisions. The subdivision has been developed with storm drainage, utility systems (excepting public sewer), paved city streets and single family residential homes. Approximately 85 % of the land disturbing activity will occur within street right-of-ways the remaining 15% within easements. The slopes in the area range from very flat 0.4% to 7 % maximum.

There are wetland and stream impacts associated with this project where proposed sewers will tie to existing sanitary sewer outfalls and along a new outfall that will be constructed along the northern boundary of Lake Rim. The USCE has been provided the PCN indicating the type, size and location of any wetland or stream impacts.

**ADJACENT PROPERTY**

Land use in to the south is generally undeveloped woodlands. Land use to the north consists of developed subdivisions. Land use to the east consists of residential areas and the head of Lake Rim. Land use to the west is also developed subdivisions. Rim Rd. runs north to south through the approximate center of the Project.

SOILS: Soils in the area are mapped as

**BaD – Blaney Loamy Sand – 8 to 15 percent slopes.** This well drained soil is on side slopes of uplands. Typically the surface layer is dark grayish brown loamy sand 4 inches thick. The subsurface layer is light yellowish brown loamy sand 21 inches thick. The subsoil, 37 inches thick, is brownish yellow sandy clay loam in the upper part and reddish yellow sandy clay loam in the lower part. The underlying material to a depth of 80 inches is yellow loamy coarse sand. Permeability is moderate, and available water capacity is low. Reaction is very strongly acid or strongly acid through the soil. The hazard of erosion is severe if the soil is exposed

**GdB – Gilead Loamy Sand – 2 to 8 percent slopes.** This moderately well drained soil is on side slopes along streams and uplands. The surface layer is dark gray loamy sand 4 inches thick. The subsurface layer is light yellowish brown loamy sand 9 inches thick. The subsoil to a depth of 70 inches is brownish yellow sandy clay in the upper part; mottles strong brown, brownish yellow, and light gray sandy clay in the middle part; and reddish yellow sandy loam in the lower part. Permeability is moderately slow or slow. The hazard of erosion is moderate where the soil is exposed.

**LaB - Lakeland Sand – 1 to 8 percent slopes.** This excessively drained soil is on broad ridges of uplands and rims of bays. The surface layer is dark gray sand 6 inches thick. The underlying material to a depth of 82 inches is yellowish brown or strong brown sand in the upper part, reddish yellow or brownish yellow sand in the middle part, and yellow sand in the lower part. Permeability is very rapid, and available water capacity is low. Reaction is strongly acid or medium acid throughout the soil.

**NoA – Norfolk Loamy Sand – 0 to 2 percent slopes.** This well drained soil is on broad, smooth flats of uplands. The surface layer is brown loamy sand 8 inches thick. The subsurface layer is light yellowish brown loamy sand 4 inches thick. The subsoil is sandy clay loam to a depth of 72 inches. It is yellowish brown in the upper part and mottled brownish yellow, red and pale brown in the lower part. Permeability is moderate, and available water capacity is medium. Reaction is strongly acid or medium acid throughout the soil.

**WaB – Wagram Loamy Sand – 0 to 6 percent slopes.** This well drained soil is on broad, smooth flats and side slopes of uplands. The surface layer is grayish brown loamy sand 8 inches thick. The subsurface layer is pale brown loamy sand 17 inches thick. The subsoil to a depth of 72 inches is yellowish brown sandy clay loam. Permeability is moderately rapid, and available water capacity is low to medium. Reaction is very strongly acid or strongly acid throughout the soil.



CONSTRUCTION PHASE

1. Obtain all permits and plan approvals.
2. Pre-construction conference.
3. Install gravel construction entrances and temp stream crossing.
4. Install sediment fencing
5. Install temporary hardware cloth inlet protection.
6. Install water bars (R/W diversions)
7. Install high flow silt sack in basins.
8. Install temporary pipe under construction protection.
9. Clear and grub permanent easements and only those portions of temporary easements necessary for construction.
10. Install water mains.
11. Install storm drainage.
12. Install sewer mains in easements. Strip topsoil during trenching operation's and separate from excavated material. Material excavated shall be placed on the uphill side of the excavation with the trench between the material and the sediment fence.
13. Remove asphalt in streets along sewer mains 3000' maximum disturbance by milling with zipper type equipment, replace cuttings back on road and compact.
14. Install sewer main and storm drainage 3000' maximum disturbance. Place ABC stone as construction progresses to pavement surface.
15. Install sewer laterals, place ABC stone as construction progresses to surface of the asphalt.
16. Test and inspect sewer main, laterals and storm drainage.
17. Patch disturbed pavement along sewer mains, laterals and storm drainage with permanent asphalt patch.
18. Seed and mulch or sod all disturbed areas not otherwise improved as indicated and establish permanent ground cover as indicated on the plans.
19. Pre final inspection by Contractor.
20. Pre final inspection by Owner and Contractor (punch list generated).
21. Final inspection (all punch list items completed with NCDENR, PWC, Owner and Designer present).
22. Remove temporary measures.
23. Closeout project.

PLANNED EROSION AND SEDIMENTATION CONTROL PRACTICES

Install temporary inlet protection utilizing high flow silt sacks at all catch basins. Install temporary silt fence and reinforce where indicated on plan at the toes of all disturbed slopes and along the downstream side of trench excavations as indicated. Install water bars along easement areas where disturbed for construction as indicated. Sodding of disturbed lawn areas is to be accomplished to provide immediate permanent stabilization as indicated. Areas not indicated as patch pave, sod or

other improvement shall be seeded. Individual sewer laterals where installed in the grass shoulder of the street R/W will be seeded and mulched and curled wood mat will be placed over the approx. 4' x 11' disturbed areas. Gravel construction entrances have been located where construction access is expected to occur, one entrance crosses a ditch and will have temporary stream crossing constructed. Temporary storm drainage under construction measure shall be installed where storm drain pipe laying terminates temporarily as well as at inlets to existing culverts as indicated on the plans. All turf areas disturbed will have topsoil set aside during excavation and replaced immediately after excavation has been backfilled. Topsoil shall have amendments added after which seeding and mulching and/or sodding shall occur. Clearing shall be limited in temporary easements to only the trees necessary to construct the improvements.

The disturbed street area will be minimized due to the requirement that trench boxes are used for construction and disturbed length of street will not exceed 3000 feet prior to patch paving. Pavement removal will be by milling and placement of milling immediately on milled area and compacted to eliminate bare soil prior to excavating for pipe. As pipe construction proceeds the aggregate base course will be required to be placed to the pavement elevation. Immediately prior to patch paving the Contractor will remove the upper portion of the stone and begin asphalt patching operations. Patch paving shall consist of placing a surface course of asphalt over the aggregate base course. In this manner disturbed streets will have minimal bare soil exposure during construction. Streets shall be swept with a motorized broom mounted on rubber tired equipment and dust shall be controlled by wetting streets as necessary to control the migration of airborne soil particles. During inclement weather Contractor shall be required to have an Emergency crew on stand by to react to emergencies including maintenance of installed measures.

All installed measures shall be maintained and inspected periodically and after each rainfall occurrence. Measures indicated in the plan are minimum requirements and shall be supplemented by contractor as necessary or as directed by NCDENR or Owner. All temporary measures shall be removed after stabilization and acceptance has occurred.

## **APPENDIX E – CERTIFICATE OF COVERAGE**

## Certificate of Coverage

STATE OF NORTH CAROLINA  
DEPARTMENT OF ENVIRONMENTAL QUALITY  
DIVISION OF ENERGY, MINERAL, AND LAND RESOURCES

GENERAL PERMIT NO. NCG010000

**NC Reference No.** NCG01-2023-1409  
**Certificate of Coverage No.** NCC231409

STORMWATER DISCHARGES

### **NATIONAL POLLUTANT DISCHARGE ELIMINATION SYSTEM**

In compliance with the provision of North Carolina General Statute 143-215.1, other lawful standards and regulations promulgated and adopted by the North Carolina Environmental Management Commission, and the Federal Water Pollution Control Act, as amended,

#### **City of Fayetteville PWC**

is hereby authorized to discharge stormwater associated with CONSTRUCTION ACTIVITIES to surface waters of North Carolina from a site located at:

Fayetteville Annexation Ph V Project IX Constr. Area 25 Lake Rim Estates & Oak M  
Gooden Drive  
City of Fayetteville  
Cumberland County

in accordance with the effluent limitations, monitoring requirements, and other conditions set forth in N.C. General Permit No. NCG010000.

This Certificate of Coverage is affiliated with **E&SC Plan Project No.** CUMBE-2023-014

This Certificate of Coverage shall become effective 5/12/2023.

This Certificate of Coverage shall remain in effect until rescinded or expired.

This Certificate of Coverage will expire on the anniversary of its effective date unless it is renewed by payment of the annual administration and compliance fee.



---

for Douglas R. Ansel, Interim Director  
Division of Energy, Mineral, and Land Resources  
By the Authority of the Environmental Management Commission

# **APPENDIX F – EASMENT SPECIAL REQUIREMENTS**

***EASEMENT SPECIAL REQUIREMENTS***

<u>Parcel Number</u>	<u>Address</u>	<u>Special Conditions</u>
9487-62-4994	1511 Rim Road	Do not disturb fencing.
9487-51-6597	9342 Tine Road	Temporary Fencing Required.
9487-50-0936		Remove all trees, stumps, and roots from easement area. Sod all areas disturbed by utility construction.
9487-50-7273	1750 Rim Road	Wooden Privacy Fence to be replaced with new wooden privacy fence.
9487-50-8017	1766 Rim Road	Temporary Fencing Required for small animals.
9486-59-8948	1774 Rim Road	Chain Link Fencing to be replaced.
9486-50-7460	1825 Cellner Drive	Temporary Fencing Required.
9486-69-0096	1873 Rim Road	Possible septic conflict.
9486-69-1447	N/A	Temporary Fencing Required.
9486-69-1537	0 Rim Road	Possible septic conflict
9486-69-1731	9597 Mountain Home Drive	Temporary Fencing Required.
9487-50-9562	1725 Rim Road	Possible septic conflict.
9487-50-9559	1717 Rim Road	Temporary Fencing Required for dog(s).
9487-50-9657	1709 Rim Road	Possible septic conflict.
9486-79-7469	957 Kennesaw Drive	Possible septic conflict.
9486-89-1378	936 Kennesaw Drive	CB building to be demoed and removed by contractor. Walnut trees marked with "X" cut
9486-79-9256	967 Kennesaw Drive	Property owner to be connected to Aqua Water main before well abandonment is completed.
9486-69-2639	9593 Mountain Home Drive	Temporary Fencing is required.
9486-69-3525	1831 Rim Road	Possible septic conflict.
9487-61-1755	1629 Rim Road	Property is presently on a shared, non-conforming lateral. Contractor will connect owner to new sanitary sewer lateral and main.
9487-61-1638	1635 Rim Road	Move lawn ornaments and landscaping stone outside the easement and set aside for the property owner. Property is presently on a shared, non-conforming lateral. Contractor will
9487-61-1610	1641 Rim Road	Property is presently on a shared, non-conforming lateral. Contractor will connect owner to new sanitary sewer lateral and main.
9487-61-0593	1649 Rim Road	Cut cedar tree in front yard along Rim Road into 24-inch lengths and left outside the PUE for owner. Property is presently on a shared, non-conforming lateral. Contractor will connect
9487-61-0359	1659 Rim Road	Property is presently on a shared, non-conforming lateral. Contractor will connect owner to new sanitary sewer lateral and main.
9487-71-4021	9445 Gooden Drive	Temporary Fencing Required along TCE. Temporary fence should be 6 ft. high. Remove/dispose of satellite dish at edge of PUE in front yard.
9487-50-1688	9361 Castle Falls Circle	Possible septic conflict.
9487-50-4871	9377 Castle Falls Circle	Temporary Fencing Required.
9487-61-1371	866 Rembrandt Drive	Remove clothesline.

## **APPENDIX G – AQUA ALL WATER DETAILS**

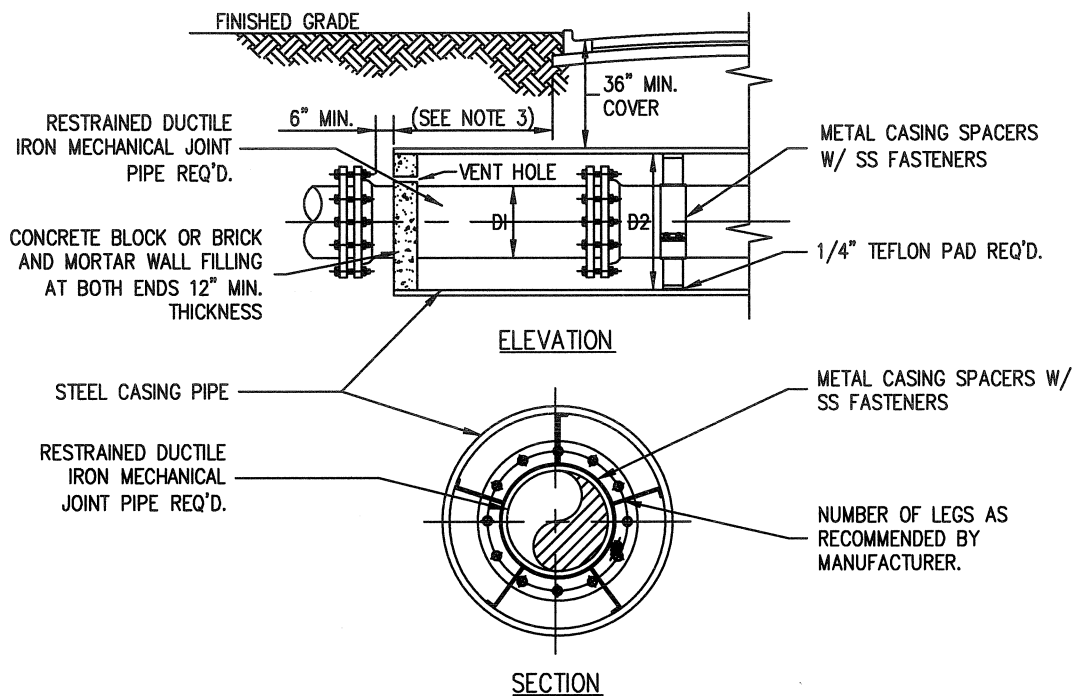

CARRIER PIPE AND CASING PIPE SIZES (MIN.)										
CARRIER PIPE NOM. DIA. (D1)	2	4	6	8	10	12	14	16	20	24
CASING PIPE NOM. DIA. (D2)	6	12	14	16	18	20	30	30	36	48
WALL THICKNESS (IN.) NCDOT	0.250	0.250	0.250	0.250	0.250	0.250	0.312	0.312	0.375	0.500
WALL THICKNESS (IN.) RAILROAD	0.250	0.250	0.250	0.250	0.312	0.375	0.500	0.500	0.563	0.625

**NOTES:**

1. WHEN CONSTRUCTION IS WITHIN NCDOT JURISDICTION, ADDITIONAL REQUIREMENTS OF THE ENCROACHMENT AGREEMENT SHALL BE MET.
2. METAL CASING SPACERS WITH BITUMINOUS COATING ARE REQUIRED AS SHOWN.
3. WHERE PRACTICAL, CASING SHALL EXTEND A MIN. OF 5' BEYOND EDGE OF PAVEMENT OR LONGER AS REQUIRED BY LOCAL PERMITTING AGENCIES.
4. A MINIMUM OF 3 CASING SPACERS PER 20 LINEAR FEET OF INSTALLED CARRIER PIPE SHALL BE PROVIDED.

DRAWING NO.  
W-1

REVISION DATE  
01/2017

BORE & JACK DETAIL CASING

**AQUA**

Aqua North Carolina, Inc.



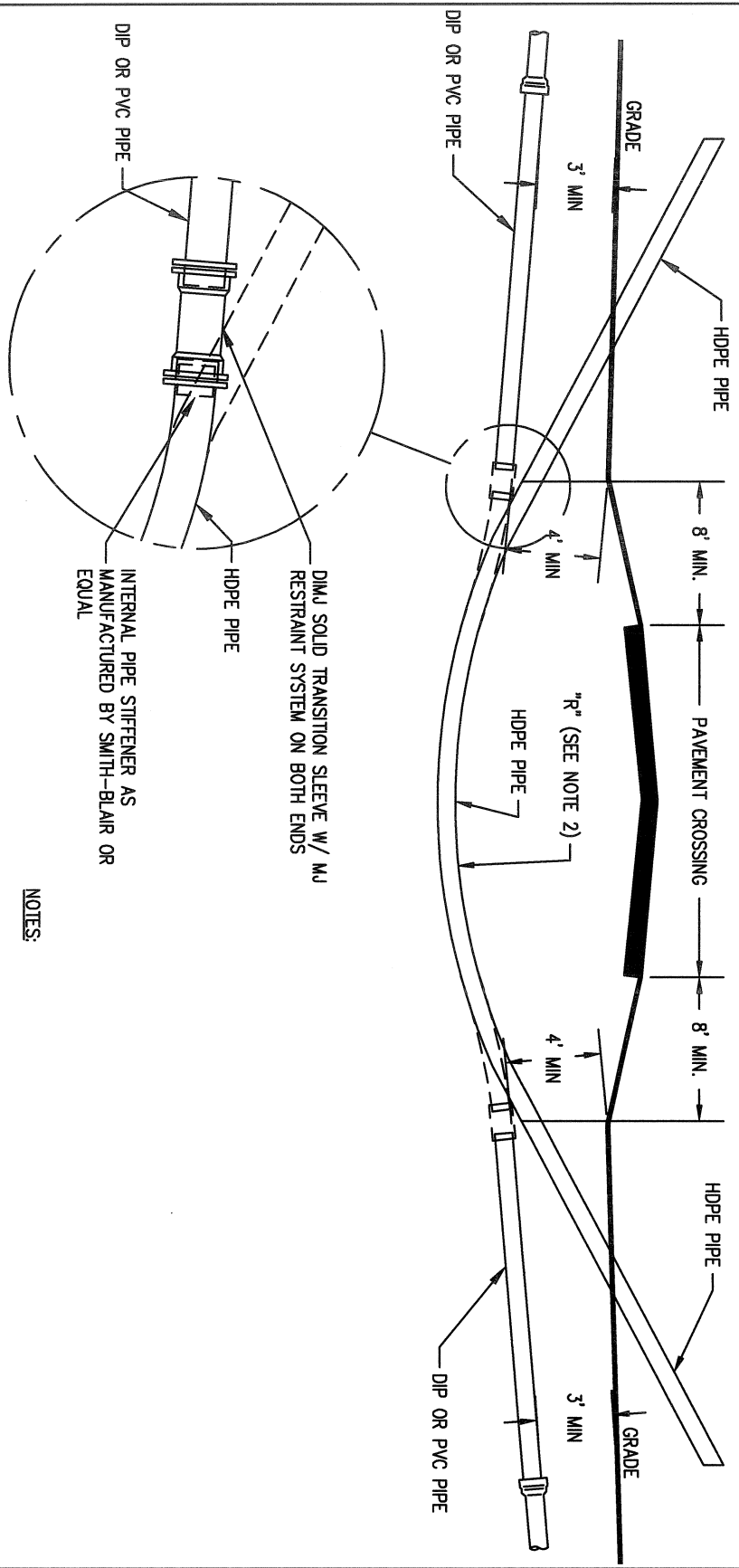

CONNECTION DETAIL (TYP. BOTH SIDES)

NOTES:

1. CONTRACTOR TO SUBMIT CALCULATIONS APPROVED BY PIPE MANUFACTURER FOR DETERMINATION OF REQUIRED HDPE PIPE THICKNESS FOR EACH INSTALLATION.
2. "R" IS TO BE BASED ON 125% OF MANUFACTURER'S RECOMMENDED MINIMUM RADIUS.
3. WHEN CONSTRUCTION IS WITHIN THE NCDOT JURISDICTION, ADDITIONAL REQUIREMENTS OF THE ENCROACHMENT AGREEMENT SHALL BE MET.

DRAWING NO. W-2
REVISION DATE 12/2011

PAVEMENT CROSSING

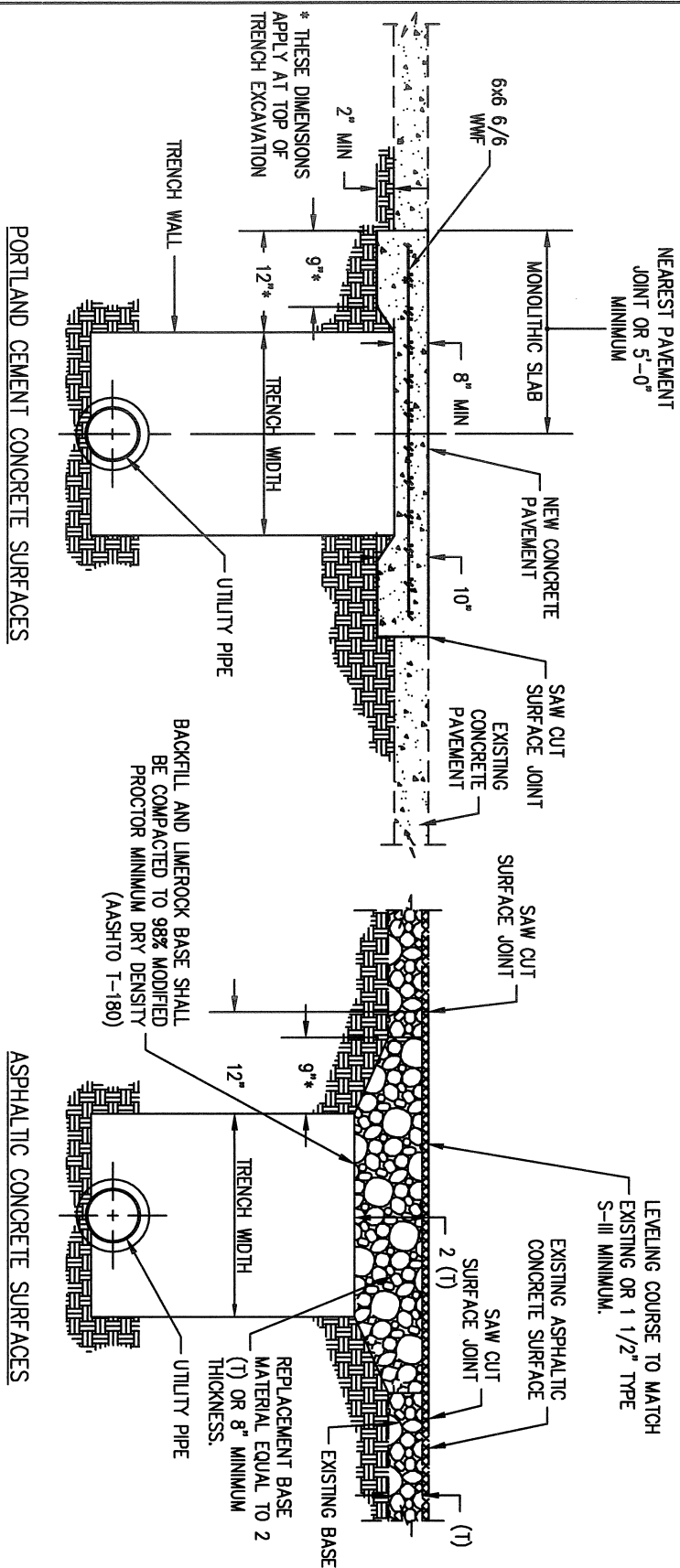

- NOTES:
1. ALL PUBLIC ROADS AND PAVED DRIVE CROSSINGS SHALL BE BACKFILLED WITH COMMON FILL MATERIAL AND TOPPED WITH AT LEAST 8" IN THICKNESS OF LIME ROCK BASE COURSE MATERIAL DURING CONSTRUCTION OF UTILITY TRENCH.
  2. IN LOCALS WHERE ABOVE DETAILS DEVIATE FROM COUNTY AND/OR CITY STANDARDS, THE CONTRACTOR SHALL PROVIDE ALL NECESSARY MATERIALS AND LABOR TO CONFORM TO SAID STANDARDS.
  3. ALL EXCAVATIONS SHALL COMPLY WITH ALL STATE LAWS AND LOCAL ORDINANCES, LATEST EDITION.
  4. TRACER WIRE AND DETECTABLE WARNING TAPE REQUIRED ON ALL SUBSURFACE UTILITY INSTALLATIONS.

DRAWING NO.  
W-3

REVISION DATE  
01/2017

STANDARD ROADWAY OPEN-CUT DETAIL

**SANITARY GRAVITY, FORCE MAIN, REUSE MAIN, STORM SEWER, & POTABLE WATER MAIN SEPARATION NOTES & SOLUTIONS**

1. A MINIMUM HORIZONTAL SEPARATION OF TEN (10) FEET OUTSIDE TO OUTSIDE SHALL BE MAINTAINED BETWEEN WATER MAINS AND SANITARY GRAVITY SEWER OR STORM SEWER LINES.
2. A MINIMUM HORIZONTAL SEPARATION OF THREE (3) FEET OUTSIDE TO OUTSIDE SHALL BE MAINTAINED BETWEEN WATER MAINS AND RECLAIMED WATER LINES CARRYING UNRESTRICTED PUBLIC ACCESS REUSE WATER.
3. IN AREAS WHERE IT IS NOT PRACTICAL TO MAINTAIN THE REQUIRED SEPARATION, THE WATER MAIN MUST BE LAID IN A SEPARATE TRENCH OR ON AN UNDISTURBED EARTH SHELVE LOCATED ON ONE SIDE OF THE SANITARY GRAVITY SEWER, STORM SEWER OR RECLAIMED WATER LINE AT SUCH AN ELEVATION THAT THE BOTTOM OF THE WATER MAIN IS AT LEAST EIGHTEEN (18) INCHES ABOVE THE TOP OF THE OTHER LINE.
4. IF THE MINIMUM ALLOWABLE TEN (10) FOOT HORIZONTAL SEPARATION OR EIGHTEEN (18) INCH VERTICAL SEPARATION IN A SEPARATE TRENCH CANNOT BE MAINTAINED, UPGRADE THE WATER MAIN TO DUCTILE IRON, IF THE OTHER LINE IS A STORM SEWER.
5. IF THE NON-CONFORMING LINE IS A GRAVITY SANITARY SEWER, AND TEN (10) FEET OF HORIZONTAL SEPARATION OR EIGHTEEN (18) INCHES VERTICAL SEPARATION IN A SEPARATE TRENCH CANNOT BE MAINTAINED, UPGRADE THE GRAVITY SANITARY SEWER (IF BEING NEWLY INSTALLED) TO AWWA C-900, D.R. 18 PVC AND HYDROSTATICALLY TEST IT TO 150psi.
6. IF THE OTHER LINE IS A RECLAIMED WATER LINE AND THE ABOVE SEPARATION REQUIREMENTS ARE NOT MET, UPGRADE THE RECLAIMED WATER LINE MATERIAL TO DUCTILE IRON.
7. DEVIATIONS AND OTHER ALTERNATIVES SHALL BE CONSIDERED ON CASE-BY-CASE BASIS AND MUST RECEIVE SPECIFIC APPROVAL BY NCDENR PRIOR TO IMPLEMENTATION.
8. THERE SHALL BE AT LEAST A TEN (10) FOOT SEPARATION BETWEEN WATER MAINS AND SANITARY SEWER FORCE MAINS WITHOUT EXCEPTION. FIELD PROBLEMS SHALL BE REPORTED TO NCDENR/ENGINEER. SPECIAL SOLUTIONS MUST BE ACCEPTED BY NCDENR PRIOR TO IMPLEMENTATION.

9. NO WATER PIPE SHALL PASS THROUGH OR COME IN CONTACT WITH ANY PART OF A SANITARY SEWER MANHOLE OR STORM SEWER STRUCTURE.

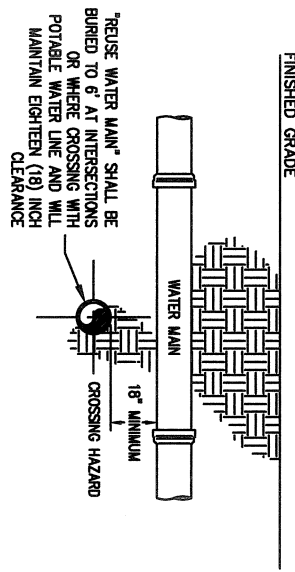

10. A MINIMUM OF VERTICAL SEPARATION OF EIGHTEEN (18) INCHES OUTSIDE TO OUTSIDE SHALL BE MAINTAINED BETWEEN WATER MAIN, SANITARY GRAVITY SEWER, STORM SEWER OR RECLAIMED WATER LINES.
11. WHEN THERE IS LESS THAN EIGHTEEN (18) INCHES VERTICAL CLEARANCE BETWEEN THE WATER MAIN AND STORM SEWER, THE WATER MAIN SHALL BE UPGRADED TO DUCTILE IRON, ONE FULL LENGTH OF PIPE SHALL BE LOCATED AT THE POINT OF CROSSING.
12. IF THE NON-CONFORMING IS A SANITARY GRAVITY SEWER WHERE THERE IS LESS THAN EIGHTEEN (18) INCHES VERTICAL CLEARANCE FROM THE WATER MAIN, UPGRADE THE SANITARY GRAVITY SEWER TO DR PVC AND HYDROSTATICALLY TEST IT TO WATER MAIN STANDARDS. PIPES SHALL BE LOCATED SO THAT JOINTS ARE AS FAR AS POSSIBLE FROM EACH OTHER.
13. IF THE OTHER LINE IS A RECLAIMED WATER LINE AND THE ABOVE MINIMUM SEPARATION IS NOT MET, UPGRADE THE RECLAIMED WATER LINE MATERIAL TO DUCTILE IRON.
14. SPECIAL STRUCTURAL SUPPORT OR CONCRETE SADDLES MAY BE NECESSARY AT THE CROSSING LOCATION.
15. IT IS PREFERABLE TO LAY THE WATER MAIN ABOVE THE CROSSING HAZARD.

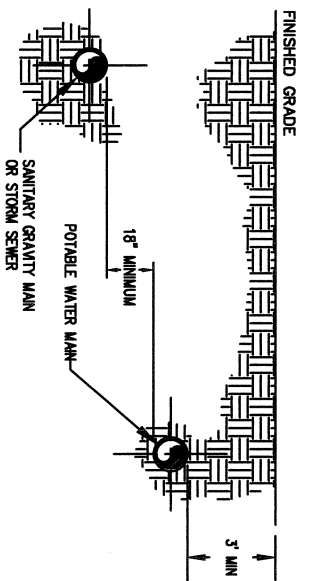
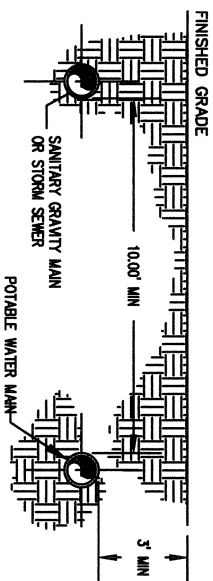

16. DEVIATIONS AND OTHER ALTERNATIVES SHALL BE CONSIDERED ON CASE-BY-CASE BASIS AND MUST RECEIVE SPECIFIC APPROVAL BY NCDENR PRIOR TO IMPLEMENTATION.
17. THERE SHALL BE AN EIGHTEEN (18) INCH VERTICAL SEPARATION BETWEEN WATER MAINS AND SANITARY SEWER FORCE MAINS AT CROSSINGS WITHOUT EXCEPTION. CONFLICTS WITH EXISTING LINES, WHERE IT IS NOT POSSIBLE TO MAINTAIN THE REQUIRED SEPARATION, IT SHALL BE REPORTED TO AQUA NORTH CAROLINA, INC./ENGINEER. SPECIAL SOLUTIONS MUST BE ACCEPTED BY NCDENR PRIOR TO IMPLEMENTATION.



Aqua North Carolina, Inc.

**UTILITY SEPARATION DETAILS**

DRAWING NO.	W-4
REVISION DATE	12/2011

- NOTES:
1. THIS DETAIL SHALL BE USED TO AVOID EXISTING UTILITIES THAT ARE SHOWN ON THE DRAWINGS.
  2. PIPE DEFLECTION MUST NOT EXCEED MANUFACTURER'S RECOMMENDATION.

TYPICAL CONFLICT RESOLUTION BY DEFLECTION  
SEE NOTES

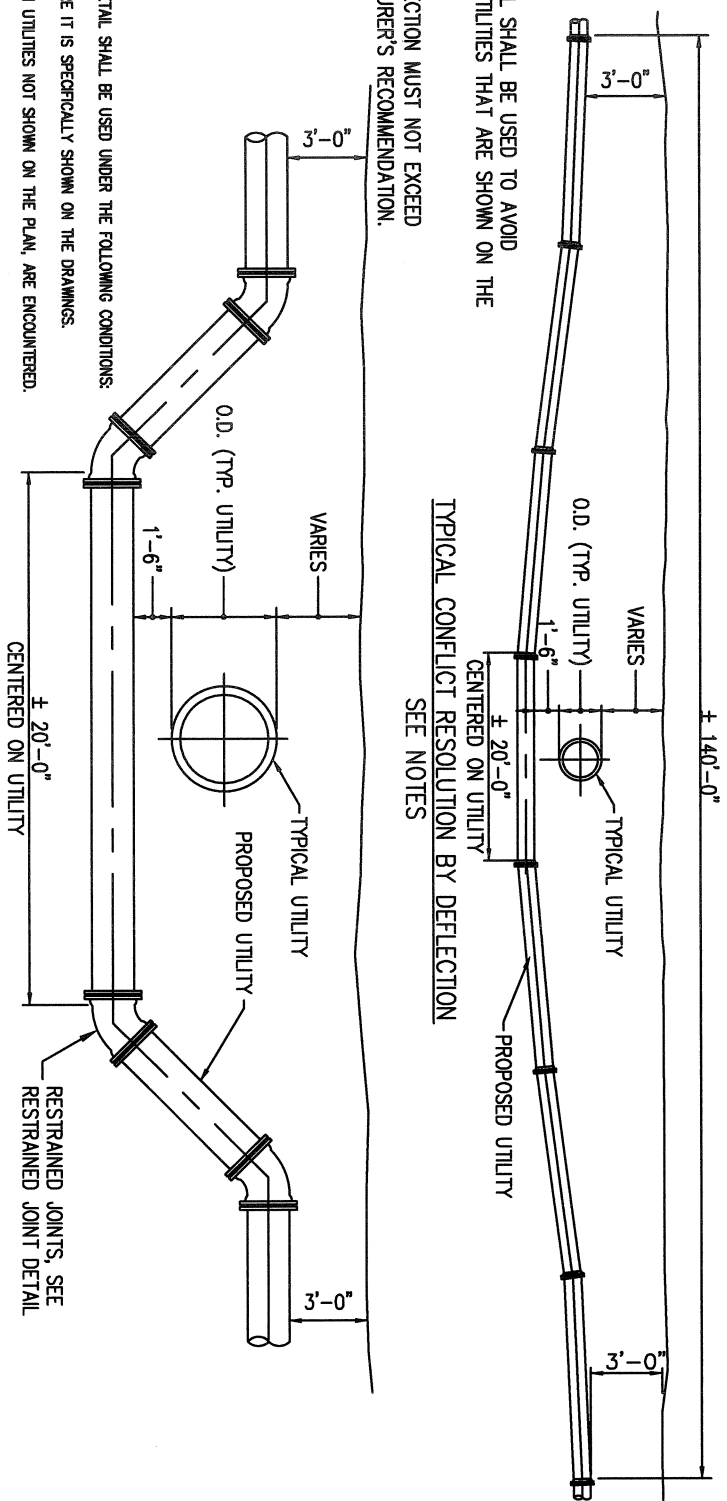

- NOTES:
1. THIS DETAIL SHALL BE USED UNDER THE FOLLOWING CONDITIONS:
    - a. WHERE IT IS SPECIFICALLY SHOWN ON THE DRAWINGS.
    - b. WHEN UTILITIES NOT SHOWN ON THE PLAN, ARE ENCOUNTERED.

DRAWING NO.	W-5
REVISION DATE	12/2011

TYPICAL CONFLICT RESOLUTION DETAIL BY DEFLECTION OR FITTINGS

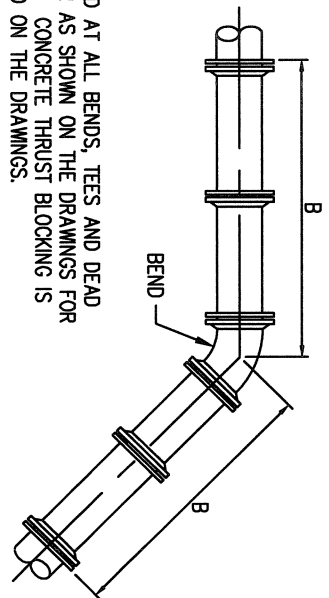
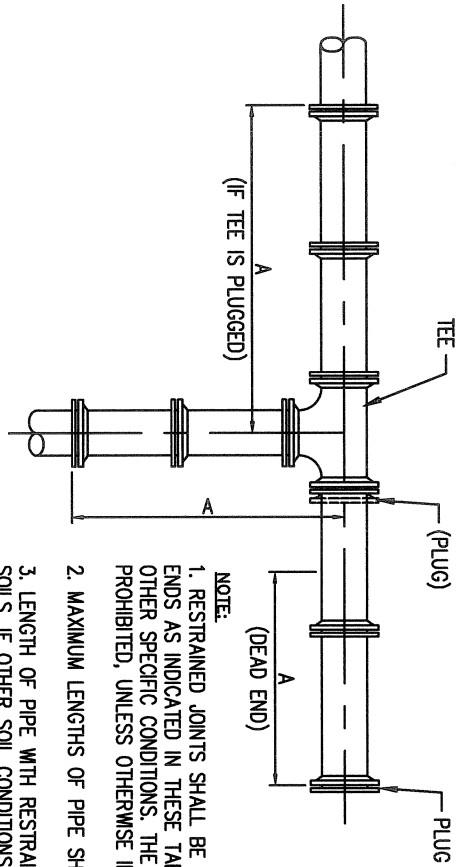

- NOTE:
1. RESTRAINED JOINTS SHALL BE PROVIDED AT ALL BENDS, TEES AND DEAD ENDS AS INDICATED IN THESE TABLES, OR AS SHOWN ON THE DRAWINGS FOR OTHER SPECIFIC CONDITIONS. THE USE OF CONCRETE THRUST BLOCKING IS PROHIBITED, UNLESS OTHERWISE INDICATED ON THE DRAWINGS.
  2. MAXIMUM LENGTHS OF PIPE SHALL BE USED WITHIN RESTRAINED SECTIONS.
  3. LENGTH OF PIPE WITH RESTRAINED JOINTS IS BASED ON INSTALLATION IN SP SOILS. IF OTHER SOIL CONDITIONS ARE ENCOUNTERED, LENGTH OF RESTRAINED PIPE SHALL BE ADJUSTED ACCORDINGLY. ENGINEER SHALL SUPPLY CALCULATIONS TO AQUA NORTH CAROLINA, INC. FOR REVIEW.
  4. PIPE TRENCH AND INSTALLATION SHALL BE DIPRA TYPE 4 AS SHOWN ON DETAILS SHEET.

LENGTH IN FEET REQUIRED FOR DIP RESTRAINED JOINTS

SIZE	A	A	B	B	B	B	B
4"	37' (55')	37' (55')	21' (26')	18' (18')	18' (18')	18' (18')	18' (18')
6"	52' (78')	52' (78')	30" (36')	18' (18')	18' (18')	18' (18')	18' (18')
8"	67' (100')	67' (100')	36' (45')	18' (18')	18' (18')	18' (18')	18' (18')
10"	81' (122')	81' (122')	44' (54')	18' (22')	18' (18')	18' (18')	18' (18')
12"	94' (141')	94' (141')	50' (63')	21' (26')	18' (18')	18' (18')	18' (18')
14"	107' (160')	107' (160')	60' (72')	23' (30')	18' (18')	18' (18')	18' (18')
16"	120' (180')	120' (180')	64' (80')	27' (33')	18' (18')	18' (18')	18' (18')
20"	144' (216')	144' (216')	80' (94')	32' (39')	18' (18')	18' (18')	18' (18')
24"	167' (250')	167' (250')	88' (108')	37' (45')	18' (18')	18' (18')	18' (18')

TABLE APPLIES TO DUCTILE IRON FOR FOLLOWING CONDITIONS:

1. TEST PRESSURE: 150 PSIG
2. SOIL TYPE: SP
3. DEPTH OF COVER: 30"
4. SAFETY FACTOR: 1.5
5. COMPACTION: AS SHOWN ON DETAIL DRAWINGS

VALUES IN PARENTHESIS ARE FOR PIPE ENCASED IN POLYETHYLENE

LENGTH IN FEET REQUIRED FOR PVC RESTRAINED JOINTS

SIZE	A	A	B	B	B	B	B
4"	45'	45'	20'	18'	18'	18'	18'
6"	63'	63'	28'	18'	18'	18'	18'
8"	82'	82'	36'	18'	18'	18'	18'
10"	98'	98'	44'	18'	18'	18'	18'
12"	116'	116'	51'	20'	18'	18'	18'
16"	148'	148'	63'	26'	18'	18'	18'
20"	179'	179'	75'	31'	18'	18'	18'
24"	208'	208'	87'	36'	18'	18'	18'

TABLE APPLIES TO PVC PIPE FOR FOLLOWING CONDITIONS:

1. TEST PRESSURE: 150 PSIG
2. SOIL TYPE: SP
3. DEPTH OF COVER: 30"
4. SAFETY FACTOR: 1.5
5. COMPACTION: AS SHOWN ON DETAIL DRAWINGS

**AQUA**

Aqua North Carolina, Inc.

RESTRAINED JOINT DETAIL

DRAWING NO. W-6

REVISION DATE 12/2011

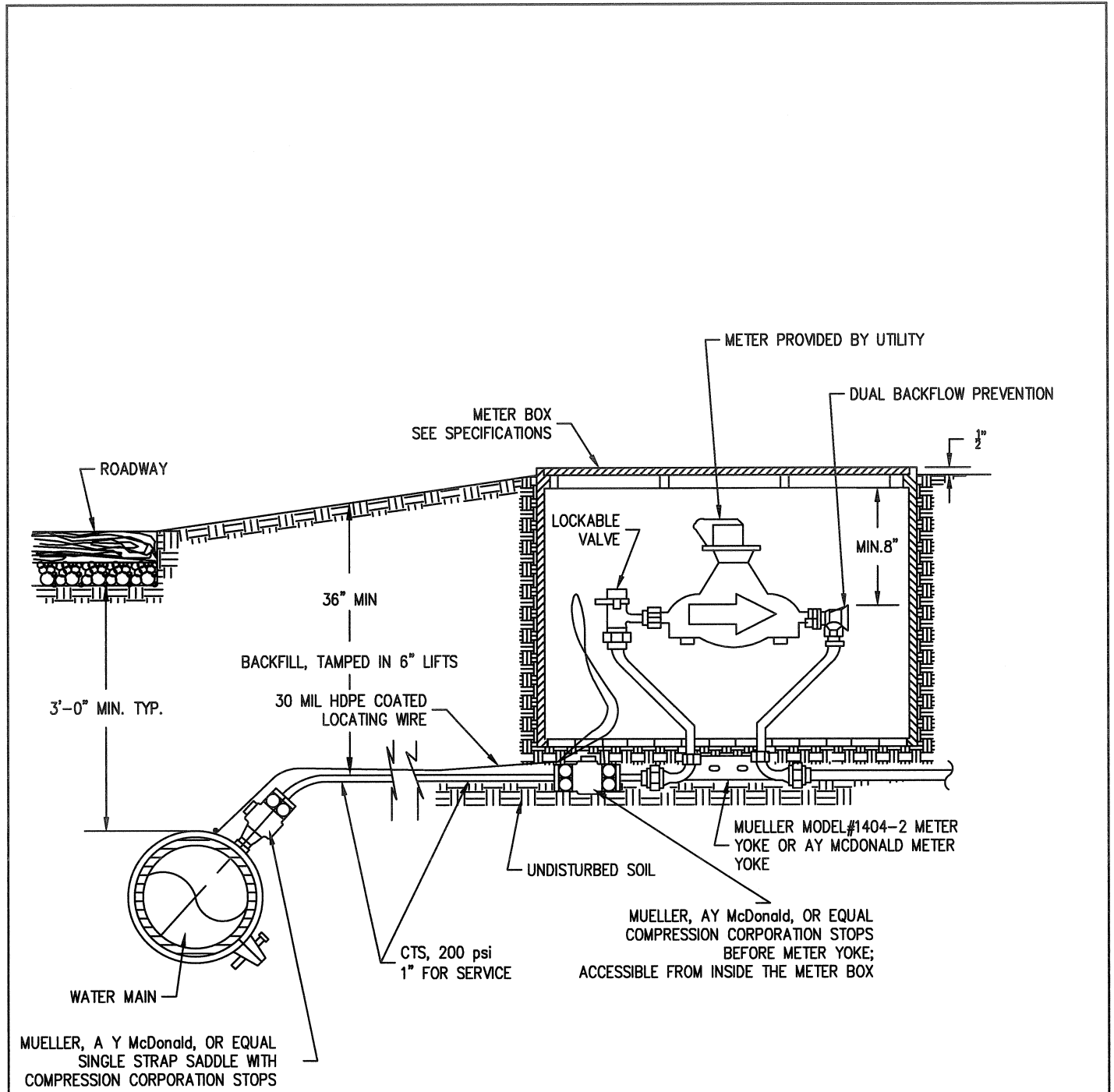

**NOTES:**

1. LOCATING WIRE SHALL TERMINATE AT MAIN AND METER BOX.
2. ALL FITTINGS SHALL BE BRASS MUELLER COMPRESSION TYPE OR STAINLESS STEEL. A PLASTIC INSERT SHALL BE INSTALLED AT ALL TERMINATIONS WHERE POLYETHYLENE PIPE IS USED.
3. ALL SERVICE PIPES UNDER ROADS OR DRIVEWAYS SHALL BE SLEEVED WITH SCH 40 PVC A MINIMUM 1 FOOT OUTSIDE OF PAVEMENT EDGE.

DRAWING NO.	W-7
REVISION DATE	11/2018

SERVICE CONNECTION

**AQUA**  
Aqua North Carolina, Inc.

NOTES:

1. METER AS PROVIDED OR APPROVED BY AQUA.
2. METER SETTERS SHALL HAVE COMPRESSION OR DUAL PURPOSE FITTINGS ON BOTH THE INLET AND OUTLET SIDES.
3. BACKFILL TAMPED IN 6" LIFTS.
4. 4" MIN. AND 12" MAX. VERTICAL CLEARANCE FROM TOP OF METER TO BOTTOM OF METER BOX COVER 4" OF 67 STONE IN BOTTOM OF METER BOX.
5. FOR 1 1/2" AND 2" WATER METER BOX INSTALLATIONS, USE CB-SO-4 FRAME AND COVER.
6. OPENING SIZES: 1 1/2" TO HAVE 13 1/4" FLANGE, 2" SERVICE TO HAVE 17 1/4" FLANGE.
7. COMPARABLE YOKES WITH HIGH RISE BYPASS AS MANUFACTURED MUELLER, AND A.Y. MCDONALD MUST BE USED.
8. METER BOX FOR 1 1/2" AND 2" METER TO BE CBS05 FRAME AND LID.

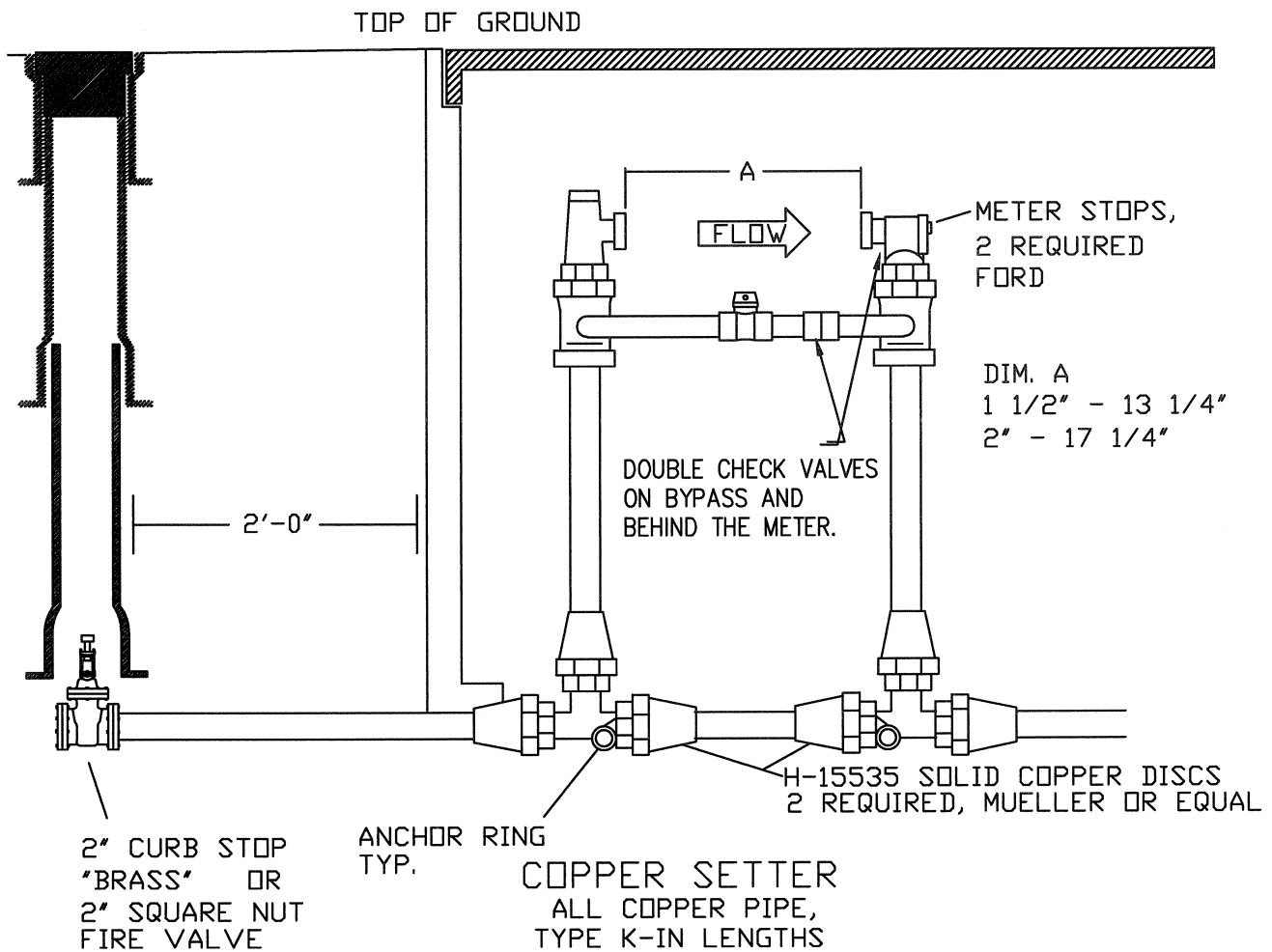

DRAWING NO. W-7A  
REVISION DATE 11/2018

TYPICAL 1.5 AND 2 INCH WATER SERVICE

**AQUA**  
Aqua North Carolina, Inc.

STANDARD 14x19 INCH DROP-IN LID WITH CAST IRON  
 READER COVER WITH 2.0 INCH REMOTE READER HOLE

MATERIAL AND SIZE WILL BE IN ACCORDANCE WITH NDS  
 D1200 STANDARD METER BOX AND LID WITH A MINIMUM  
 OF POLYPROPYLENE BOX BODY AND LID WITH A CAST  
 IRON METER FLAP.

DIMENSIONS (INCHES)

A	B
14.5" INSIDE	19.75" INSIDE
16.25" OUTSIDE	21.5" OUTSIDE

NOTES:

In non-traffic loading areas, a standard plastic  
 meter box may be used. It must contain a cast  
 iron reader flap with the dial centered under the  
 reader flap. Installation must follow standard  
 detail W-7.

The meter box and lid must be a NDS D1200 or  
 alternative approved by Aqua.

PLACEMENT IN TRAFFIC LOADING AREAS MUST BE  
 APPROVED BY AQUA IN WRITING. THE METER BOX  
 AND LID MUST BE APPROVED PER EACH REQUEST.  
 NON-TRAFFIC LOADING PLACEMENT IS PREFERRED.

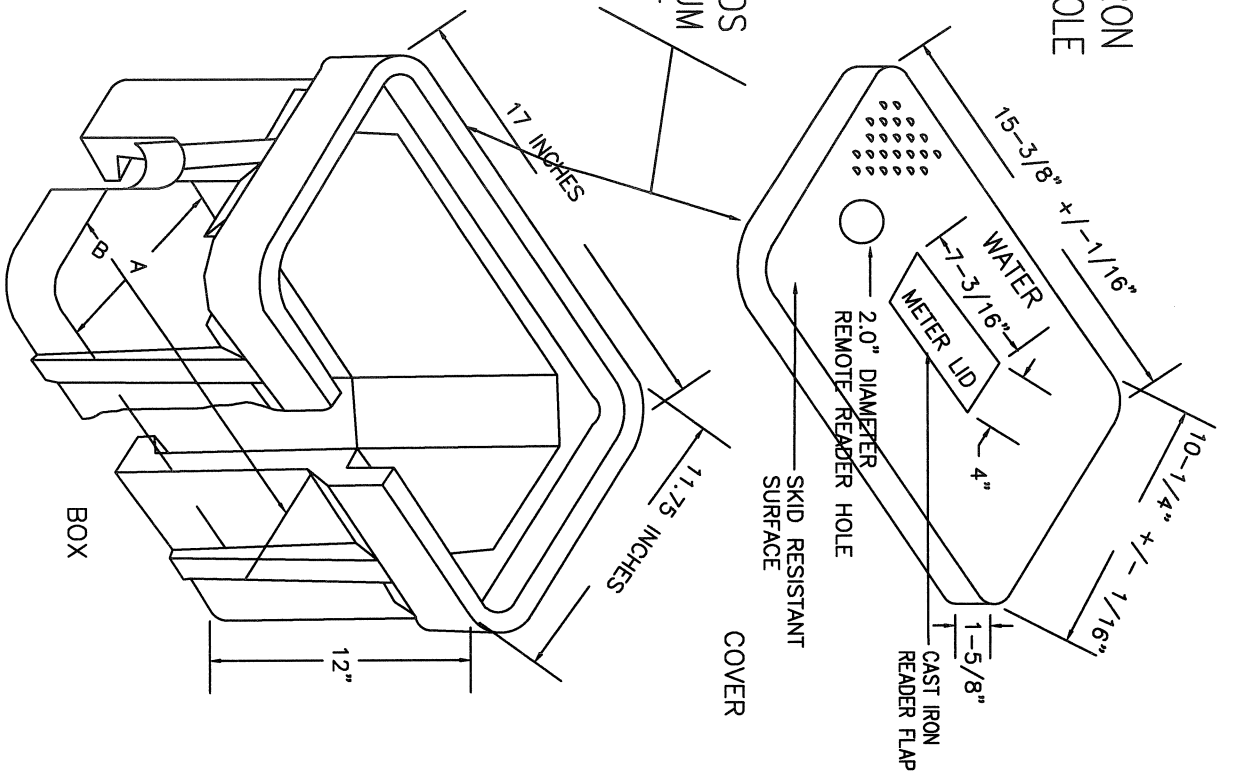

DRAWING NO.  
**W-7B**  
 REVISION DATE  
**01/2019**

STANDARD WATER METER BOX AND LID  
 1 INCH METER AND SMALLER

**AQUA**  
 Aqua North Carolina, Inc.



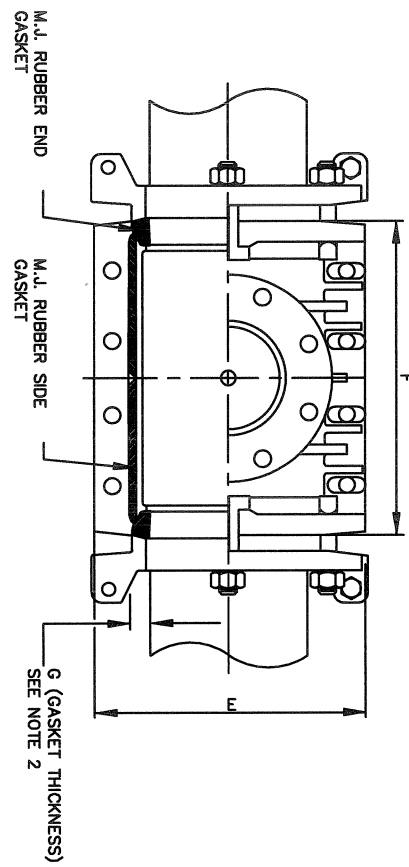
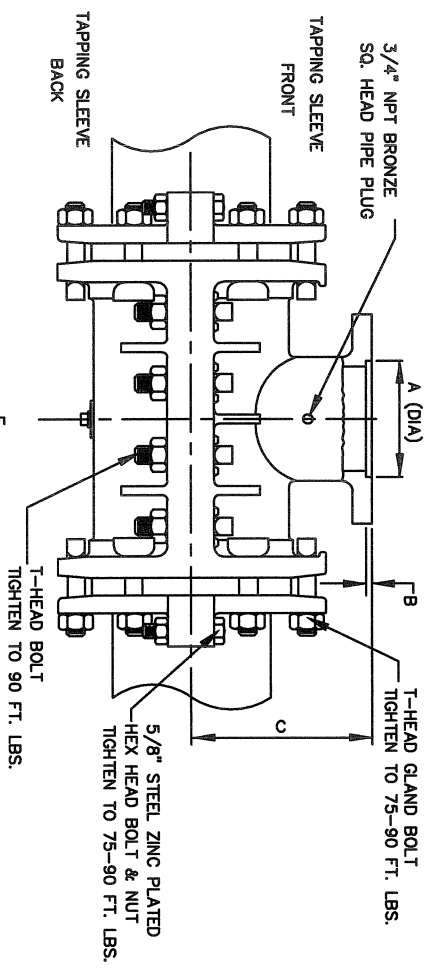

- NOTES:
1. ALL MATERIALS SHALL BE IN ACCORDANCE WITH AQUA NORTH CAROLINA STANDARDS. SLEEVE BODY SHALL BE DUCTILE IRON ASTM A536.
  2. MECHANICAL JOINT TAPPING SLEEVES SHALL BE AS MANUFACTURED BY CLOW, M & H, MUELLER, OR AMERICAN AND SHALL BE FINISHED WITH SPLIT GLANDS, SPLIT END GASKET, BOLTS, ETC. THE OUTLET FLANGE SHALL BE CL 125 PER ANSI B16.1 COMPATIBLE WITH APPROVED TAPPING VALVES.
  3. DIMENSIONS SHOWN ARE FOR REFERENCE AND MAY VARY BASED UPON MANUFACTURER. SLEEVES SHALL BE SIMILAR IN NATURE TO THAT SHOWN AND SHALL NOT DEVIATE IN ESSENTIAL DETAILS.
  4. PIPE SURFACES SHALL BE CLEANED THOROUGHLY TO PERMIT FOR A GOOD SEAL PRIOR TO INSTALLATION.
  5. EXTERIOR OF TAPPING SLEEVE SHALL BE COATED w/2 COATS ASPHALTIC VARNISH MIL-C450.
  6. ALL TAPPING SLEEVES SHALL BE HYDROSTATICALLY PRESSURE TESTED PRIOR TO THE TAP BEING ACCOMPLISHED. TEST SHALL BE APPROVED BY AQUA NORTH CAROLINA PROJECT COORDINATOR PRIOR TO BEGINNING TAPPING PROCESS.
  7. SEE TAPPING VALVE FOR ADDITIONAL INFORMATION.

SLEEVE FOR USE WITH CI OR DI PIPE

SLEEVE SIZE PIPE X BRANCH	6X6	8X6	8X8	12X6	12X8	12X12	16X6	16X8	16X12	24X6	24X8	24X12	24X16	24X24	30X6	30X8	30X12	30X16	30X24
A DIA	7.016	7.016	9.016	7.016	9.016	13.016	7.016	9.016	13.016	11.00	13.5	19.0	23.5	32.0	11.00	13.5	19.0	23.5	32.0
+ .031 - .000	.31	.31	.31	.31	.31	.31	.31	.31	.31	.31	.31	.31	.31	.31	.31	.31	.31	.31	.31
C	7-7/8	9-1/16	9	11-5/8	11-7/8	12-7/8	14-1/8	14-1/2	14-7/8	19.5	19.5	19.5	20.5	20.5	23.25	23.25	23.25	23.75	23.75
E	11-3/4	13-7/8	13-7/8	18-1/2	18-1/2	18-1/2	23-1/2	23-1/2	23-1/2	35.5	35.5	35.5	35.5	35.5	43.37	43.37	43.37	43.37	43.37
F	13-1/2	15	15	19-1/2	19-1/2	19-1/2	22-1/2	22-1/2	22-1/2	18.0	18.0	24.0	30.0	36.0	24.0	24.0	24.0	36.0	36.0

DRAWING NO. W-8  
 REVISION DATE 12/2011

NOMINAL PIPE SIZE (INCH)	BRANCH SIZE	APPROX. WT. LBS.
4"	3", 4"	28, 30
6"	3", 4", 6"	36, 38, 45
8"	3", 4", 6", 8"	42, 44, 48, 66
10"	3", 4", 6", 8", 10"	45, 48, 55, 70, 80,
12"	3", 4", 6", 8", 10", 12"	50, 52, 60, 81, 96, 143
16"	3", 4", 6", 8", 10", 12"	78, 80, 85, 100, 115, 172
24"	3", 4", 6", 8", 10", 12"	85, 87, 90, 100, 145, 230

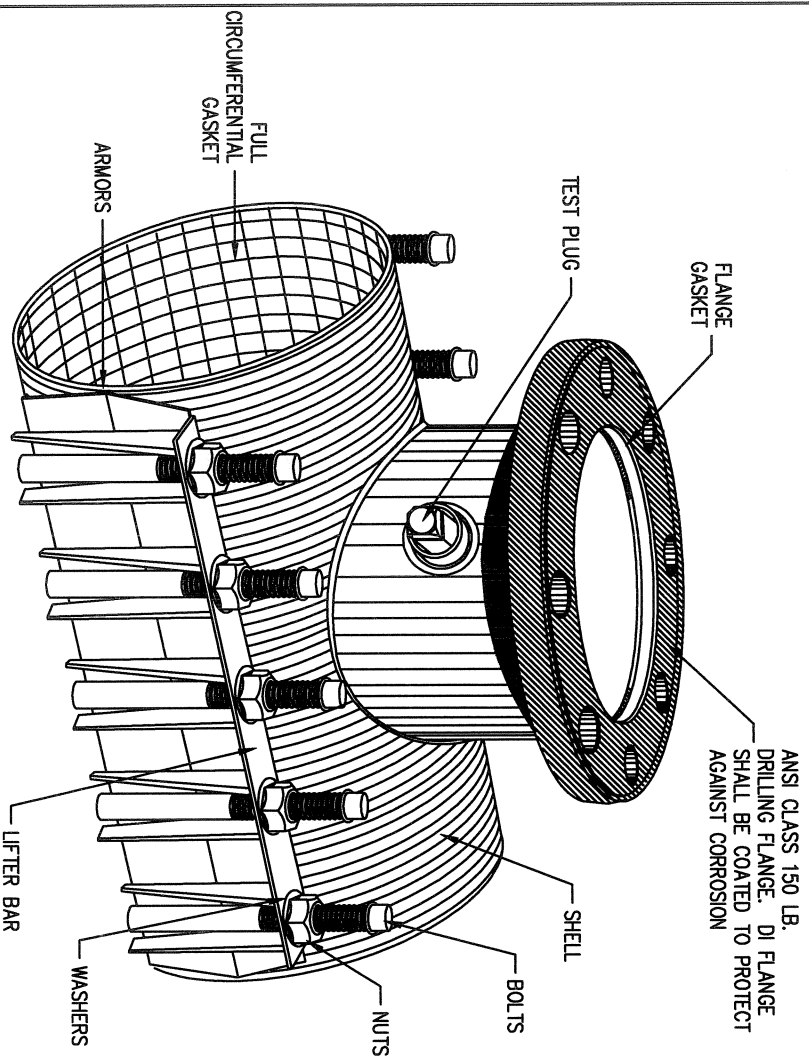

- NOTES:**
1. ALL MATERIALS SHALL BE IN ACCORDANCE WITH AQUA NORTH CAROLINA STANDARDS.
  2. TAPPING SLEEVES SHALL BE AS MANUFACTURED BY ROMAC, SMITH-BLAIR, OR APPROVED EQUAL.
  3. STAINLESS STEEL TAPPING SLEEVE MAY BE UTILIZED FOR ALL TAPPING OF MAINS UP TO AND INCLUDING 24" DIAMETER WITH 12" OR LESS BRANCH. BRANCH GREATER THAN 12" SHALL REQUIRE FULL BODY D.I. M.U. TAPPING SLEEVE. (SEE DETAIL W.9).
  4. SHELL AND LUGS SHALL BE STAINLESS STEEL PER ASTM A 240, TYPE 304 AND 304L.
  5. BOLTS SHALL BE 5/8" UNC ROLLED THREAD, STAINLESS STEEL PER ASTM A 193 TYPE 304 4" NOM. PIPE SIZE SHALL HAVE MIN. 1/2" BOLTS.
  6. NUTS SHALL BE HEAVY HEX STAINLESS STEEL PER ASTM A-194, TYPE 304.
  7. WASHERS SHALL BE STEEL AND PLASTIC LUBRICATING WASHER.
  8. GASKETS SHALL BE VIRGIN SBR PER ASTM D 2000 MAA 610, COMPOUNDED FOR WATER AND SEWER SERVICE.
  9. FLANGE SHALL BE DUCTILE IRON PER ASTM 536, GRADE 65-45-12; OR STAINLESS STEEL PER ASTM A-240, TYPE 304.
  10. DIMENSIONS SHOWN ARE FOR REFERENCE AND MAY VARY BASED UPON MANUFACTURER. SLEEVES SHALL BE SIMILAR IN NATURE TO THAT SHOWN AND SHALL NOT DEVIATE IN ESSENTIAL DETAILS.
  11. PIPE SURFACES SHALL BE CLEANED THOROUGHLY TO PERMIT A GOOD SEAL PRIOR TO INSTALLATION.
  12. ALL TAPPING SLEEVES SHALL BE HYDROSTATICALLY PRESSURE TESTED PRIOR TO THE TAP BEING ACCOMPLISHED. TEST SHALL BE APPROVED BY AQUA NORTH CAROLINA PROJECT COORDINATOR PRIOR TO BEGINNING TAPPING PROCESS.
  13. THE NUMBER OF BOLTS, NUTS AND WASHERS SHOWN ARE FOR ILLUSTRATION ONLY, ACTUAL QUANTITY SHALL BE AS RECOMMENDED BY THE SLEEVE MANUFACTURER FOR THE REQUIRED SERVICE.
  14. SEE TAPPING VALVE DETAIL (W.9) FOR ADDITIONAL INFORMATION.

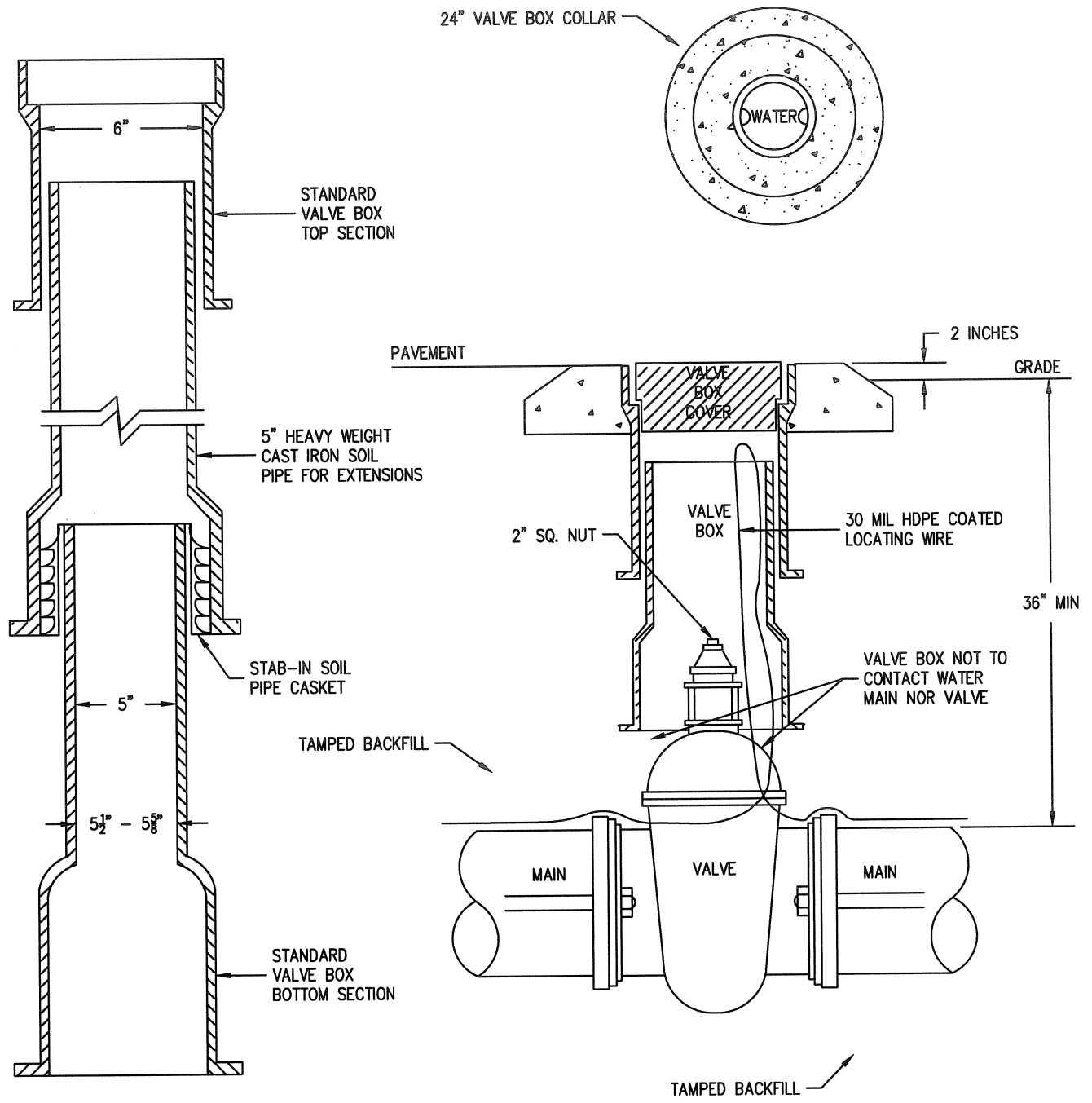

**NOTES:**

1. GATE VALVES SHALL COMPLY WITH AWWA C-500 AND BE IRON BODY, PARALLEL SEAT TYPE, BRONZE FITTED W/ RESILIENT SEAT. LEFT HAND OPEN (CCW).
2. 2'X2'X4" CONCRETE PAD MAY BE USED IN SUBSTITUTE OF 24" COLLAR.

DRAWING NO. W-10
REVISION DATE 01/2017

GATE VALVE AND EXTENSION

**AQUA**  
Aqua North Carolina, Inc.

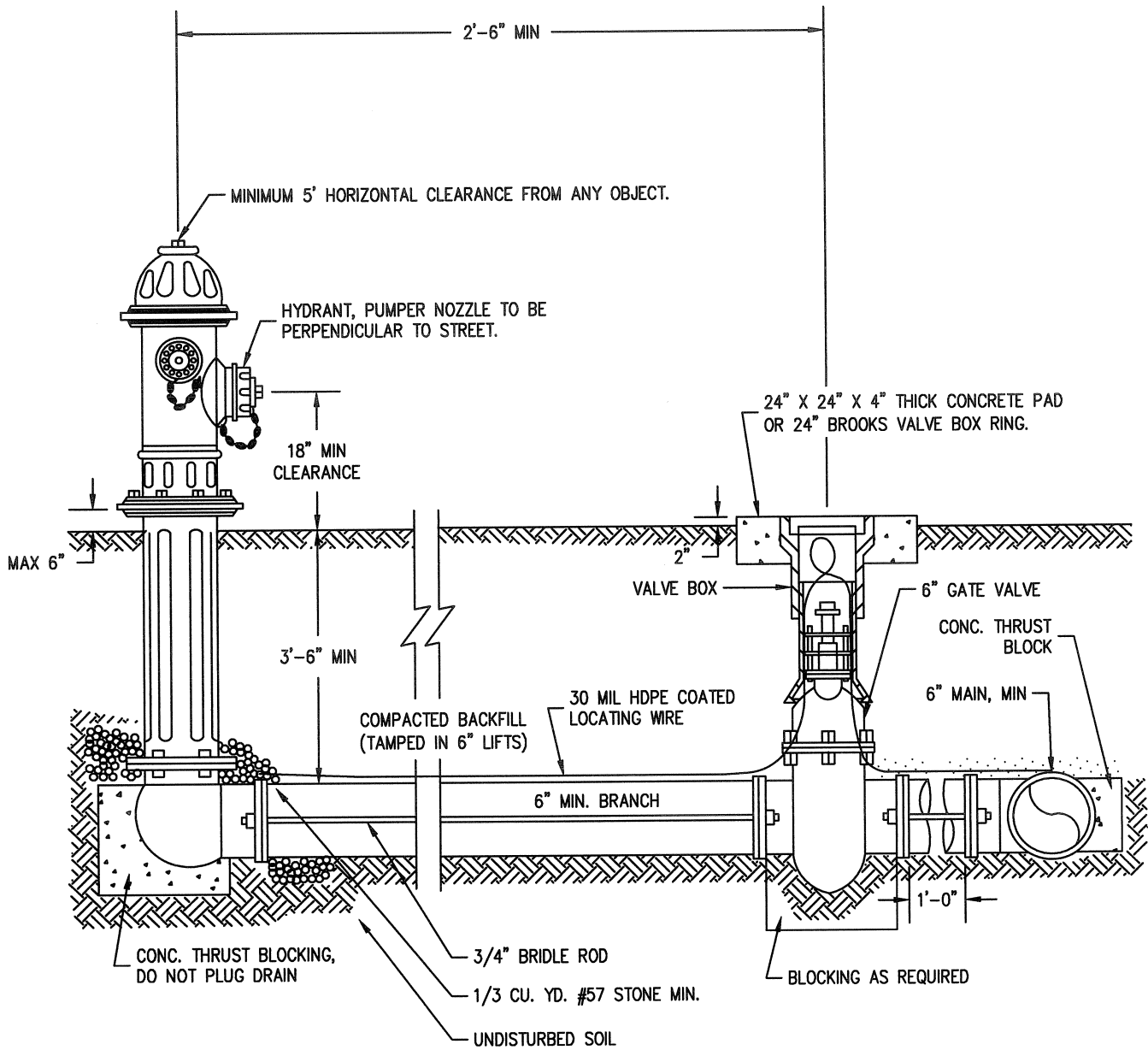

**NOTES:**

1. ALL HYDRANTS SHALL BE CONSTRUCTED IN ACCORDANCE WITH AWWA STANDARD C503-82.
2. HYDRANTS WILL BE INSTALLED IN TRUE VERTICAL POSITIONS.
3. ALL BENDS, TEES, VALVES AND BLOW-OFFS SHALL BE BLOCKED IN ACCORDANCE WITH AWWA STANDARDS.
4. HYDRANTS SHALL HAVE NATIONAL STANDARD THREADS.

DRAWING NO. W-11
REVISION DATE 01/2017

HYDRANT DETAIL

**AQUA**

Aqua North Carolina, Inc.

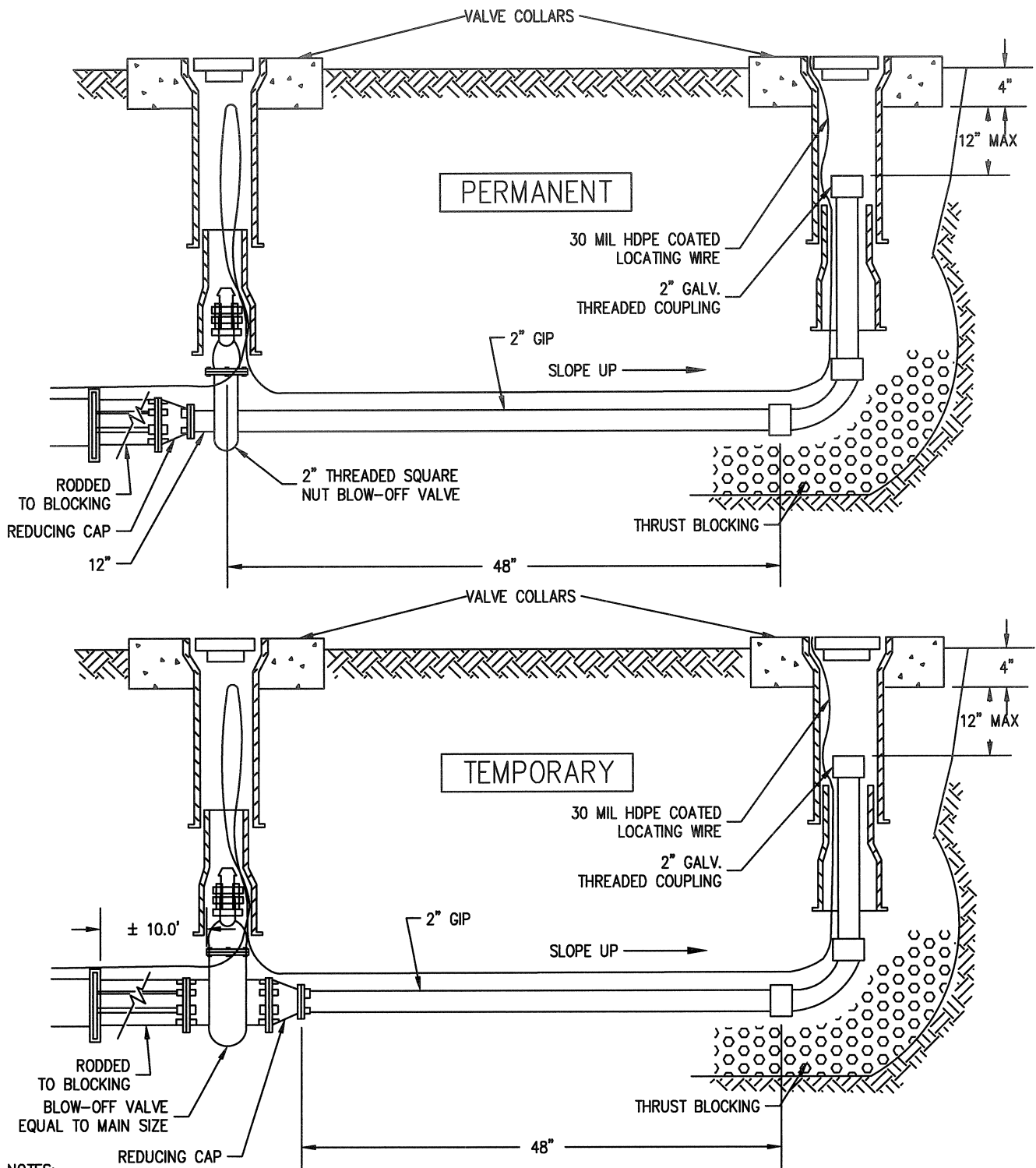

**NOTES:**

1. BLOW-OFFS ARE REQUIRED ON ANY PERMANENT AND/OR TEMPORARY DEAD END MAINS AND ARE TO CONSTRUCTED PER APPROVED PLANS.
2. ALL BENDS, TEES, VALVES AND BLOW-OFFS SHALL BE BLOCKED IN ACCORDANCE WITH AWWA STANDARDS.
3. BLOW-OFF TO BE APPROVED BY UTILITY PRIOR TO INSTALLATION.

DRAWING NO. W-12
REVISION DATE 01/2017

BLOW-OFF DETAIL

**AQUA**

Aqua North Carolina, Inc.

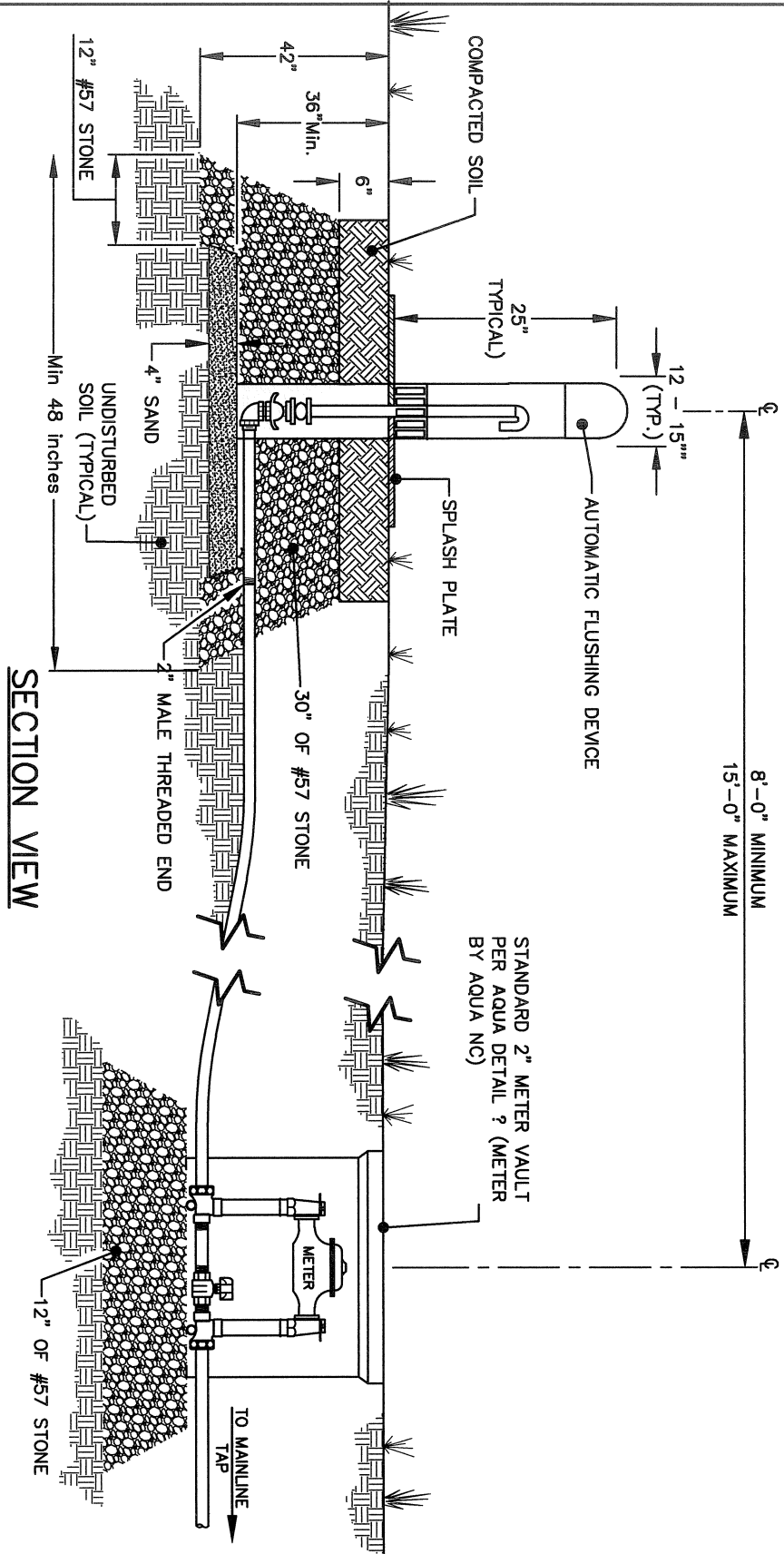

- NOTES:**
1. FLUSHING DEVICE SHALL BE HYDROGUARD MODEL H-3 AS MANUFACTURED BY MUELLER.
  2. PIPING SHALL BE 2 INCH PER AQUA SPECIFICATIONS
  3. AREA AROUND FLUSHING DEVICE SHALL BE GRADED TO FACILITATE FLOW AWAY FROM THE SPLASH PLATE.
  4. ENTIRE ASSEMBLY SHALL BE LOCATED IN A DEDICATED AQUA NC EASEMENT OR AS DIRECTED.

STANDARD AUTOMATIC FLUSHING DEVICE

DRAWING NO.  
W-12 A  
REVISION DATE

STANDARD AUTOMATIC FLUSHING DEVICE

**AQUA**  
Aqua North Carolina, Inc.

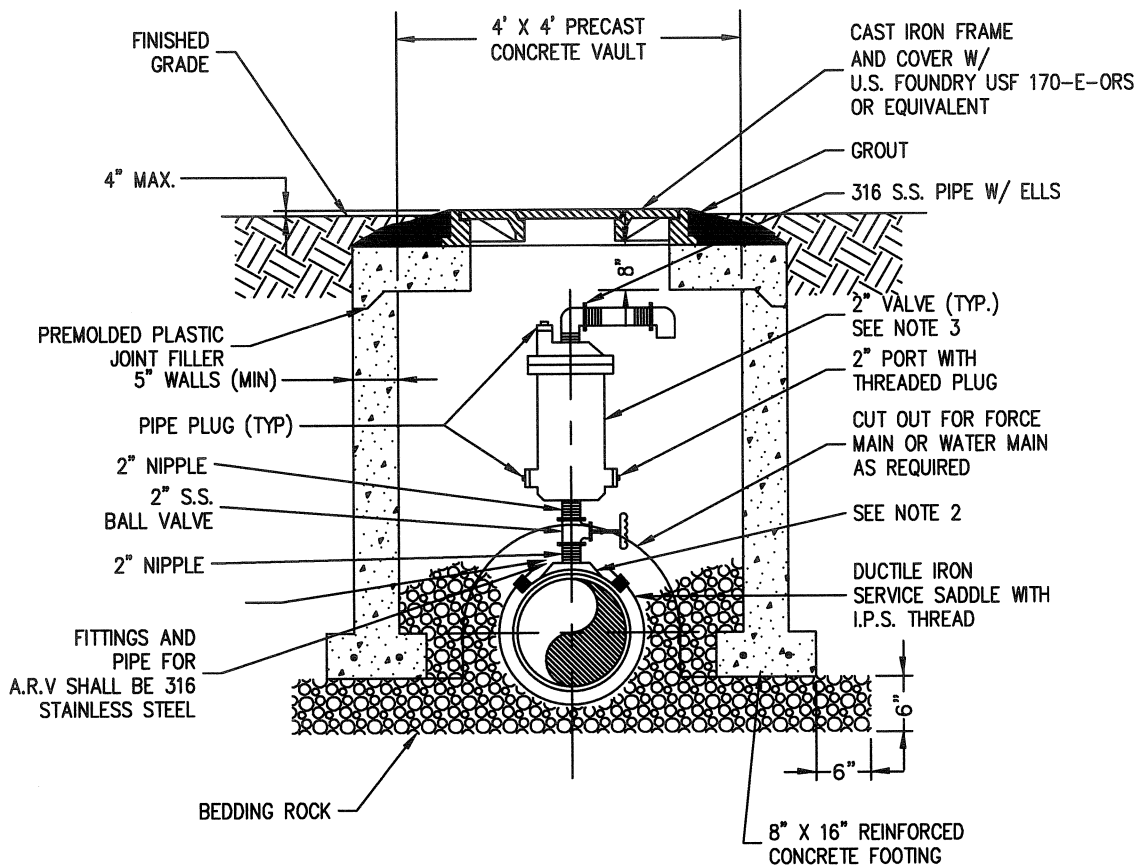

**NOTES:**

1. ABOVE DETAIL IS BASED ON 2" AIR RELEASE VALVE. CHANGE PIPE AND FITTINGS ACCORDINGLY FOR OTHER VALVE SIZES. VALVE SIZES SHALL BE DETERMINED BY THE ENGINEER AND APPROVED BY AQUA NORTH CAROLINA, INC. PRIOR TO INSTALLATION.
2. THE MINIMUM DIMENSION FROM TOP OF PIPE TO FINISHED GRADE SHALL BE 4.0 FEET.
3. FOR POTABLE WATER MAINS VALVE SHALL BE APCO #200 (2") OR EQUIVALENT

DRAWING NO. W-13
REVISION DATE 12/2011

AIR RELEASE VALVE DETAIL

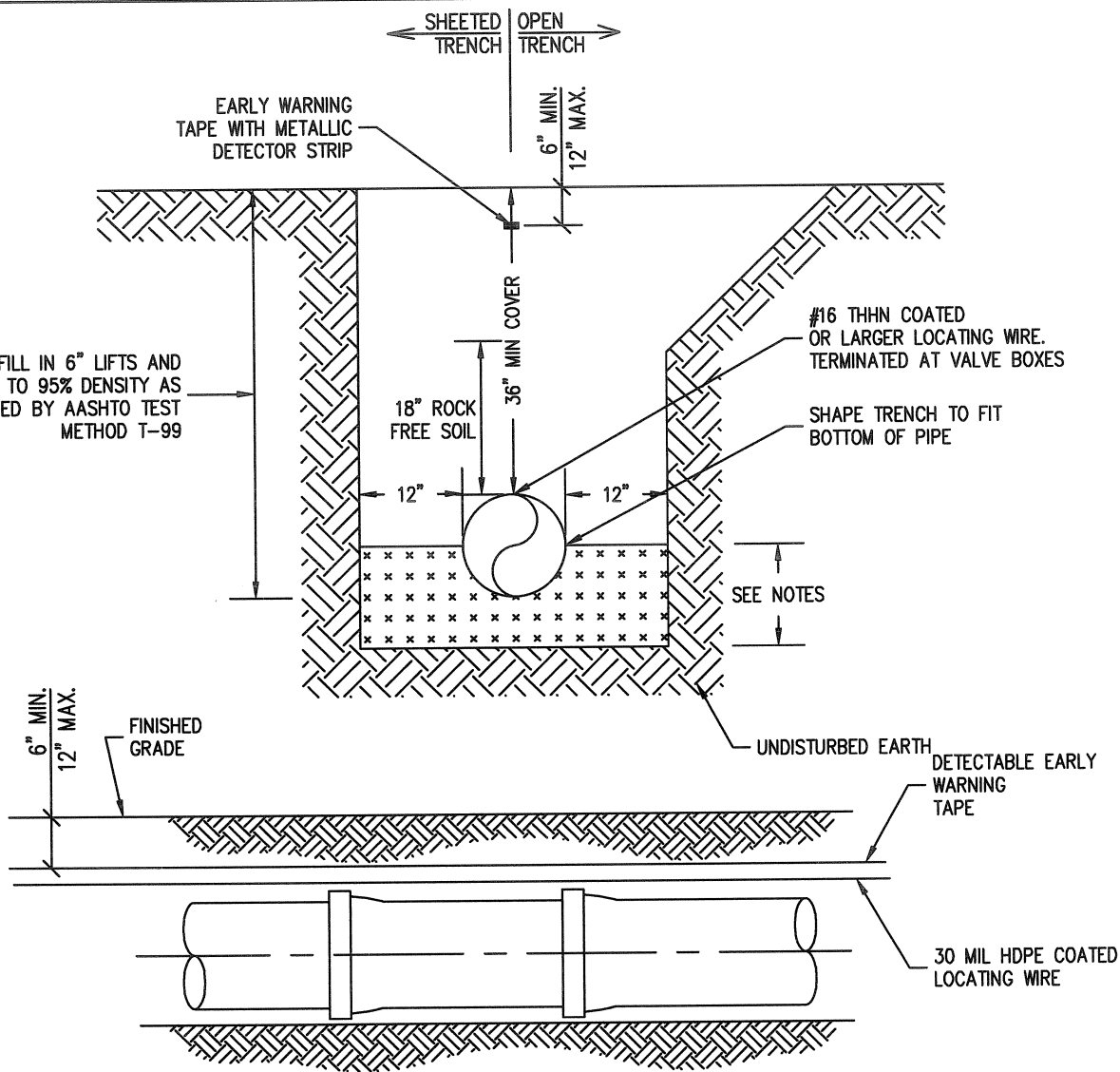

**NOTES:**

1. WHERE ROCK OR NON-CUSHIONING MATERIAL IS ENCOUNTERED IN TRENCH, USE #5 STONE FOR A DEPTH OF 8" UNDER PIPE.
2. WHERE UNSUITABLE SOIL OR MUCK IS ENCOUNTERED, EXCAVATE THE SOIL AND BACKFILL WITH #5 STONE TO FORM A PIPE BED.
3. PVC AND DUCTILE IRON MAINS SHALL MEET ALL STANDARDS AS CALLED OUT IN THE SPECIFICATIONS (DIVISION 5, SECTION 1.3.3).
4. ALL WATER MAINS SHALL HAVE A DETECTABLE "EARLY WARNING" PROTECTION TAPE AND HDPE LOCATING WIRE INSTALLED CONTINUOUSLY ALONG THE ALIGNMENT. THE PROTECTION TAPE AND WIRE SHALL BE INSTALLED DURING BACKFILLED 6"-12" INCHES BELOW FINISHED GRADE DIRECTLY OVER THE PIPE AND BE CONTINUOUSLY MARKED "CAUTION, WATER MAIN BURIED BELOW." THE TAPE SHALL HAVE A METALLIC DETECTABLE STRIP INCLUDED AND BE GREEN IN COLOR. ALL PROTECTION TAPE SHALL BE AS TERRA-TAPE OR EQUAL.
5. ALL P.V.C. WATER MAINS SHALL BE EITHER A SOLID BLUE COLOR OR WHITE BLUE LETTERING. ALL LETTERING SHALL APPEAR ON THREE SIDES OF THE PIPE AND SHALL RUN THE ENTIRE LENGTH OF THE PIPE AND SHALL BE A MINIMUM 3/4 INCH IN HEIGHT WITH THE APPROPRIATE WORDING APPEARING ONE OR MORE TIMES EVERY 21 INCHES ALONG THE LENGTH OF THE PIPE. THE LETTERING MUST BE PERMANENTLY STENCILED TO THE PIPE SURFACE. LETTERING SHALL READ AS IS ACCEPTABLE FOR THE INTENDED USE. ALL LETTERING SHALL BE APPLIED BY THE PIPE MANUFACTURER DURING PRODUCTION.
6. ALL DUCTILE IRON WATER MAINS SHALL BE MARKED WITH A CONTINUOUS STRIPE LOCATED WITHIN THE 90° OF THE PIPE. SAID STRIPE SHALL BE A MINIMUM 2-INCHES IN WIDTH AND SHALL BE BLUE IN COLOR. BACKFILL SHALL NOT BE PLACED FOR 30 MINUTES FOLLOWING PAINT APPLICATION.
7. ALL P.V.C. PIPE SHALL BEAR THE NATIONAL SANITATION FOUNDATION (NSF) SEAL OF APPROVAL FOR POTABLE WATER PIPE.

DRAWING NO. W-14
REVISION DATE 01/2017

TRENCH DETAIL

**AQUA**

Aqua North Carolina, Inc.



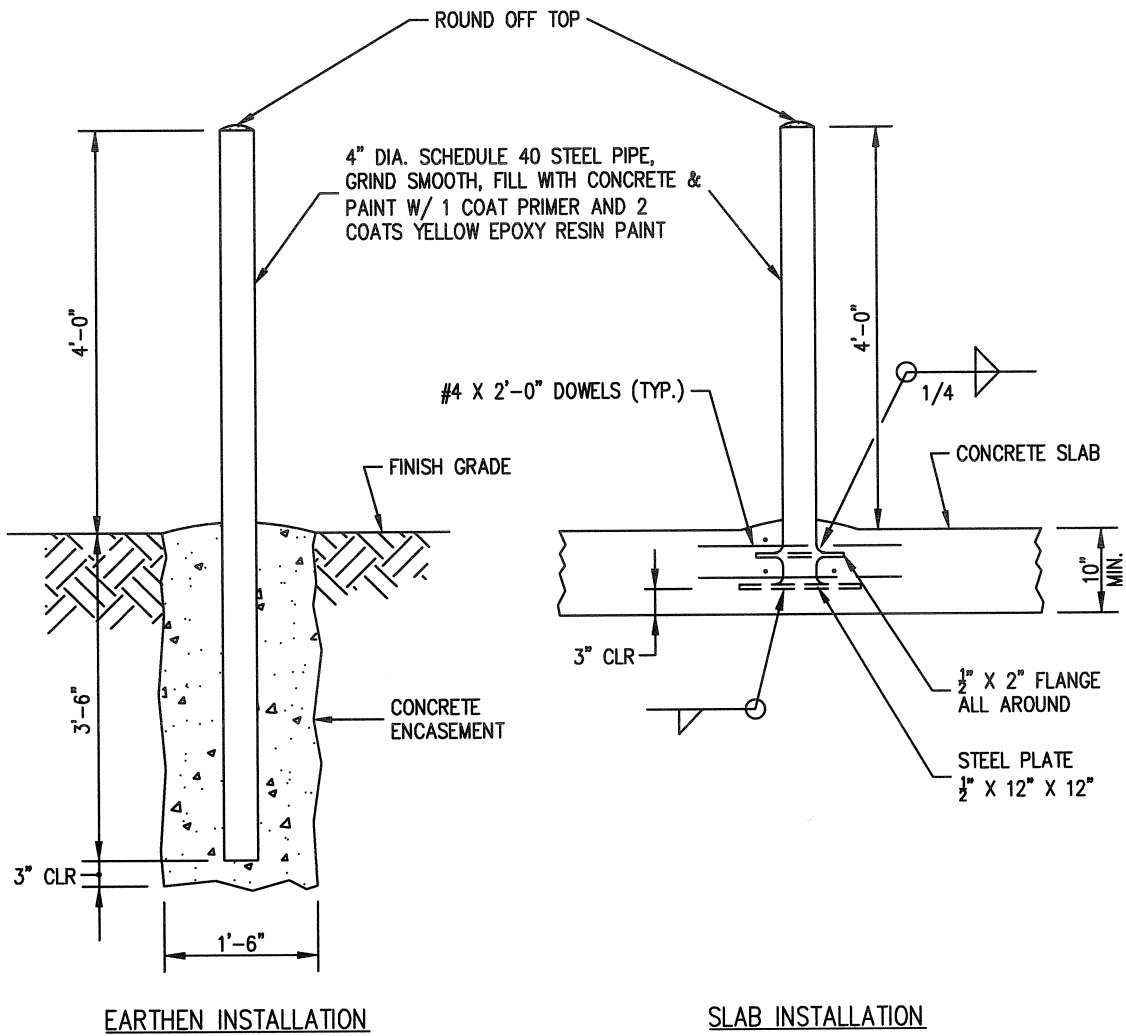

DRAWING NO.  
W-15

REVISION DATE  
12/2011

GUARD POST DETAIL

**AQUA**

Aqua North Carolina, Inc.

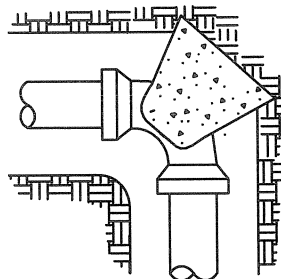

ELBOW

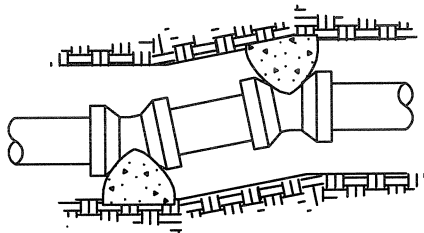

HORIZONTAL BEND

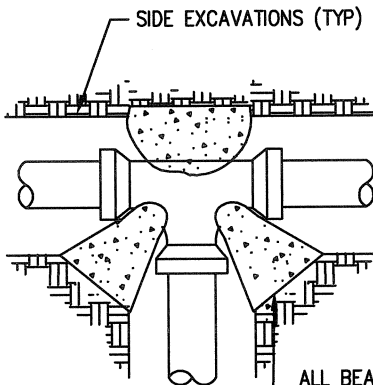

TEE

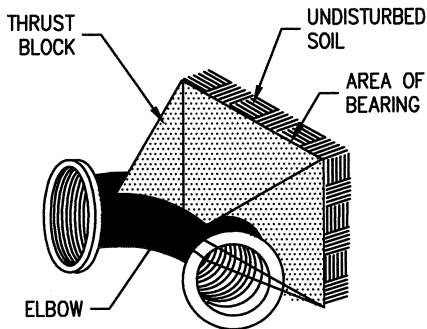

MIN. BEARING AREA EACH DIRECTION  
OF THRUST IN SQUARE FEET  
(based on soil supporting value of 2000 psf @ 200 psig test pressure)

PIPE SIZE	TEES & DEAD ENDS	90° ELBOWS	45° ELBOW & CROSSES	22-1/2° ELBOWS
6"	4	6	3	2
8"	7	10	5	3
12"	15	21	11	6

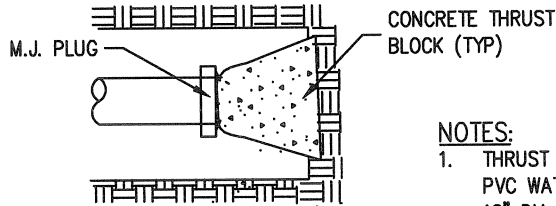

DEAD END

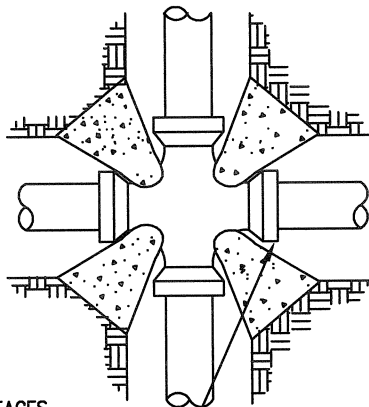

CROSS

CONCRETE SHALL BE KEPT CLEAR OF PIPE JOINTS (TYP)

**NOTES:**

1. THRUST BLOCKS SHALL BE INSTALLED ON PVC WATER DISTRIBUTION LINES 4" THRU 12" DIA. IN THE MANNER SHOWN.
2. PIPE GREATER THAN 12 INCH DIAMETER SHALL REQUIRE RESTRAINT JOINT PIPE FOR THE PROPER LENGTH.
3. COMPACT FITTINGS ARE NOT ACCEPTABLE. STANDARD FITTINGS SHALL BE USED WITH CONCRETE THRUST BLOCKING.
4. THRUST BLOCKS SHALL BE INSTALLED ON WATER MAIN IN THE MANNER SHOWN.
5. IF SAC-CRETE IS USED, MIXING MUST BE ON SITE UTILIZING A MECHANICAL MIXER AND AN AQUA REPRESENTATIVE MUST BE PRESENT.
6. NO CONCRETE SHALL BE PLACED ON BOLTS. WRAP JOINT FITTINGS WITH PLASTIC.
7. CONCRETE SHALL BE A MINIMUM 3,000 psi AND THE TICKETS TURNED INTO THE UTILITY.
8. ALL BEARING SURFACES SHALL BE AGAINST UNDISTURBED SOIL AND SHALL BE APPROVED BY AQUA PROJECT COORDINATOR PRIOR TO PLACEMENT OF CONCRETE.
9. USE OF RESTRAINED JOINT DUCTILE IRON WILL BE REQUIRED IF SOIL CONDITIONS DO NOT ALLOW THE USE OF THRUST BLOCKS.
10. ALL VERTICAL BENDS SHALL BE RESTRAINED USING RESTRAINED JOINT DUCTILE IRON PIPE.

DRAWING NO.  
W-16

REVISION DATE  
01/2019

TYPICAL THRUST BLOCK

**AQUA**

Aqua North Carolina, Inc.

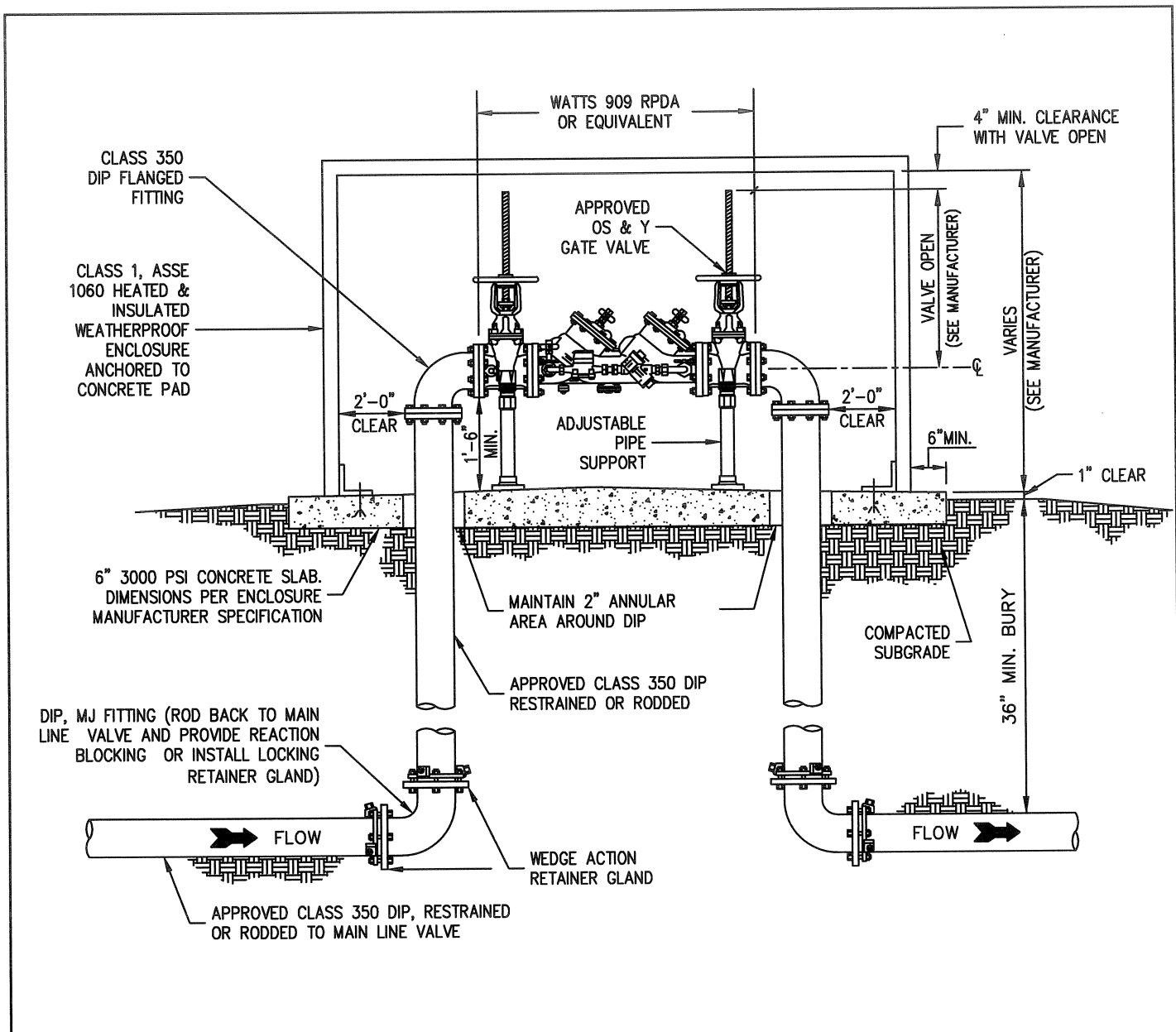

**Notes:**

1. ALL PIPES, VALVES AND FITTINGS 2" AND SMALLER SHALL BE AS SPECIFIED IN DIVISION 3, SECTION 13.4
2. ACCEPTABLE MODELS:
  - WATTS 090
  - FEBCO 825Y (D)
  - WILKINS 975 XL
  - CONBRACO 400
  - OR APPROVED EQUAL
3. THIS DETAIL IS REPRESENTATIVE OF ACCEPTABLE REDUCED PRESSURE ZONE BACKFLOW DEVICES FOR SERVICES 2" IN DIAMETER OR SMALLER THAT ARE INSTALLED WITHIN AQUA NORTH CAROLINA'S SYSTEMS.

DRAWING NO.  
W-17

REVISION DATE  
12/2011

REDUCED PRESSURE BACKFLOW PREVENTER

**AQUA**  
Aqua North Carolina, Inc.

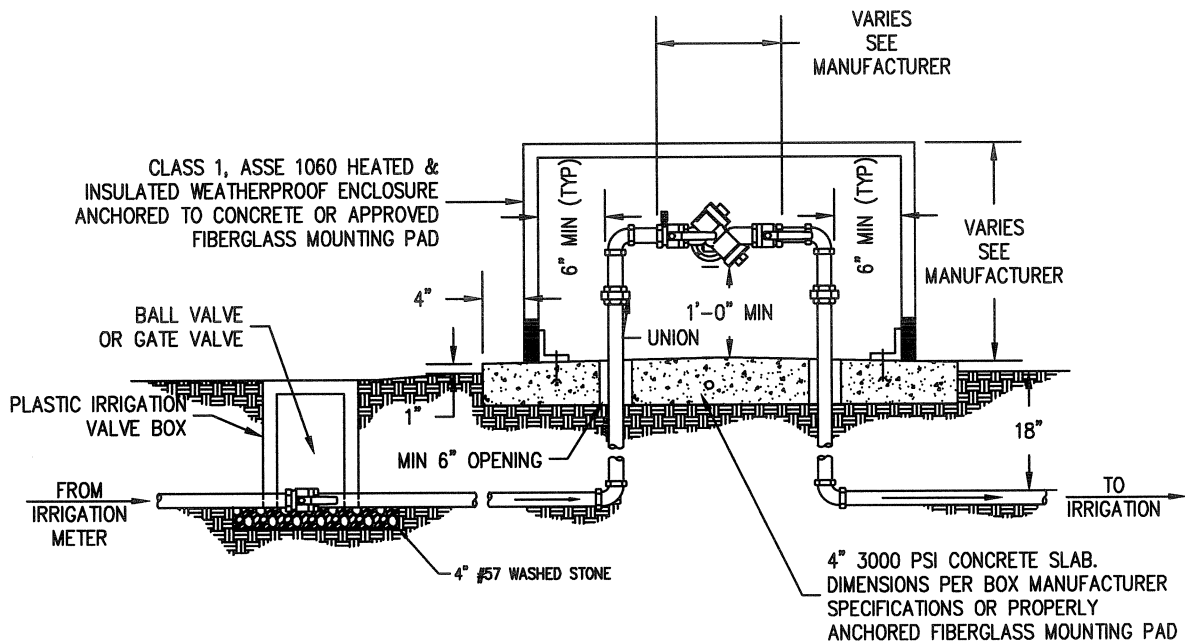

**NOTES:**

1. BACKFLOW ASSEMBLY SHALL COMPLY WITH ASSE 1013 & AWWA C511.
2. ASSEMBLY SHALL BE INSTALLED WITHIN 5' OF THE IRRIGATION METER WITH NO PRIOR CONNECTIONS ON THE LINE.
3. ASSEMBLY SHALL BE CENTERED ON CONCRETE MOUNTING PAD AND CENTERED WITHIN ENCLOSURE.
4. MINIMUM CLASS 1, ASSE 1060 HEATED & INSULATED WEATHERPROOF ENCLOSURE REQUIRED.
5. PIPE MATERIAL SHALL BE PVC (SCH. 80 OR BETTER)
6. INSTALLATION SHALL BE IN COMPLIANCE WITH N.C. PLUMBING CODE.
7. PROPERTY OWNER SHALL BE RESPONSIBLE FOR MAINTENANCE AND OPERATION OF BACKFLOW ASSEMBLY AND COMPLIANCE WITH REPORTING AND TESTING REQUIREMENTS.

DRAWING NO.	W-18
REVISION DATE	12/2011

REDUCED PRESSURE BACKFLOW PREVENTER, 2" SERVICES & SMALLER

**AQUA**

Aqua North Carolina, Inc.

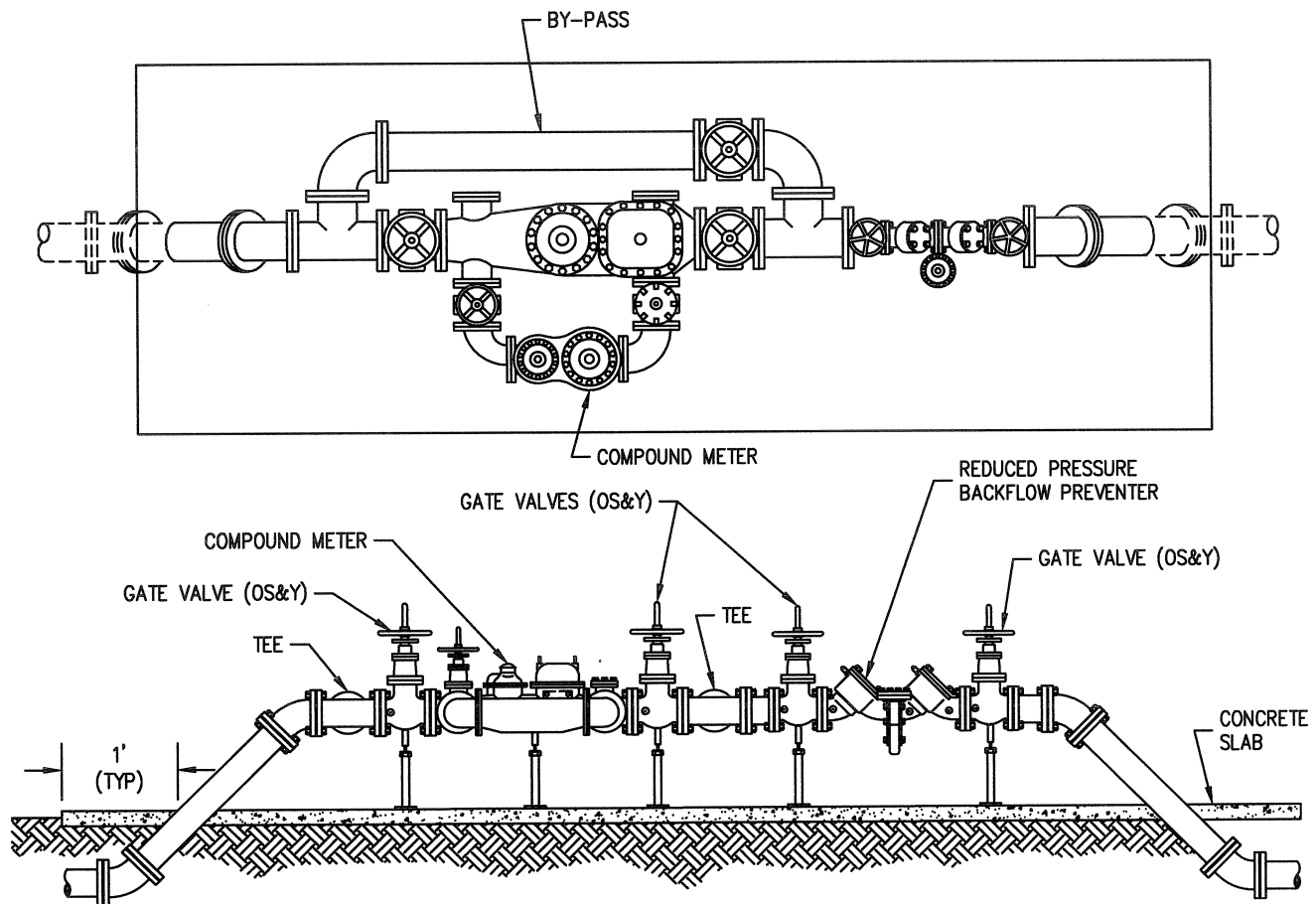

**NOTES:**

1. ALL FITTINGS ABOVE GRADE SHALL BE FLANGED.
2. ALL FITTINGS BELOW GRADE SHALL BE MECHANICAL JOINT W/ LOCKING GLANDS.
3. ALL PIPE SUPPORTS SHALL BE ADJUSTABLE.
4. CONCRETE SLAB SHALL BE 4" THICK (2" ABOVE GRADE) AND EXTEND 1' OUTSIDE INSTALLATION ALL DIRECTIONS.
5. ALL VALVES SHALL BE OS&Y.
6. METER BY-PASS MUST HAVE AN ADJUSTABLE PIPE SUPPORT.
7. ALL ABOVE GROUND PIPE SHALL BE PROTECTED FROM FREEZING.

DRAWING NO.  
W-19

REVISION DATE  
12/2011

SERVICE CONNECTIONS FOR COMPOUND METERS AND BACKFLOW PREVENTOR  
ASSEMBLY 3", 4", 5", 8" AND 10"

**AQUA**  
Aqua North Carolina, Inc.

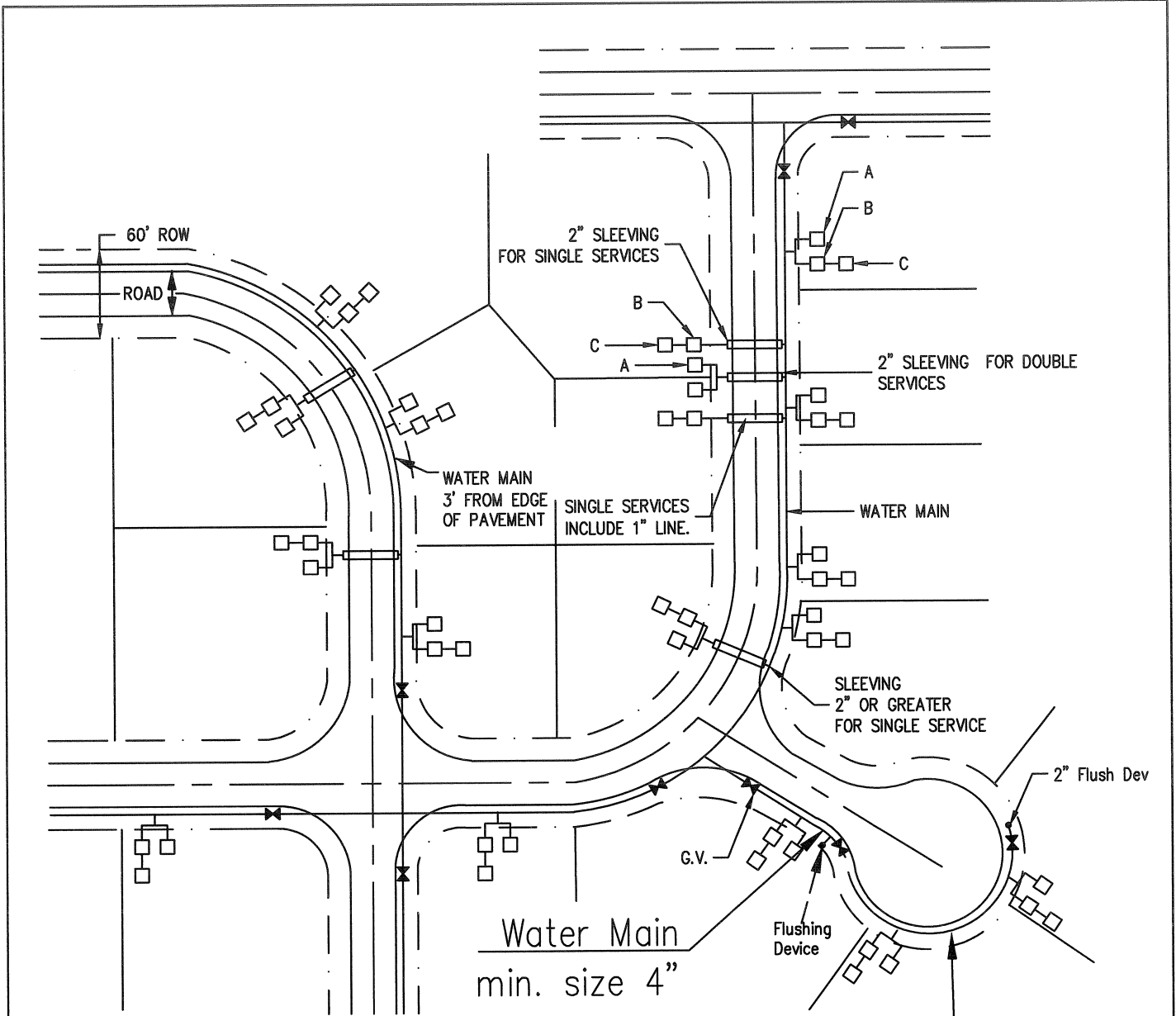

**KEY:**

- A = DOMESTIC METER
- B = IRRIGATION METER
- C = BACKFLOW ASSEMBLY

WHEN GRAVITY SEWER IS WITHIN THE CUL-DE-SAC:  
 The water line must be wrapped around outside of the pavement and a reduction to 2 inch water line will be allowed from the start/top/head of the cul-de-sac to its termination.

**NOTES:**

1. SINGLE SERVICES TO BE LOCATED AT CENTER OF LOT.
2. DOUBLE SERVICES TO BE LOCATED AT LOT LINE.
3. SINGLE SERVICES ONLY WHEN LOTS ARE A MINIMUM OF 2 ACRES OR IRRIGATION IS INSTALLED.
4. DEPENDING ON THE PRESENCE OF GRAVITY SEWER WITHIN THE CUL-DE-SAC - FLUSHING DEVICES ON CUL-D-SAC CAN EXTEND AROUND CURVE OR TERMINATE FROM STRAIGHT RUN.
5. DOUBLE SERVICES SHALL BE 1" DIAMETER MINIMUM AND SLEEVED WITH 2" PVC UNDER PAVED AREAS.

DRAWING NO.	W-20
REVISION DATE	11/2018

TYPICAL WATER SYSTEM LAYOUT WITH GRAVITY SEWER IN THE CUL-DE-SACs

**AQUA**

Aqua North Carolina, Inc.

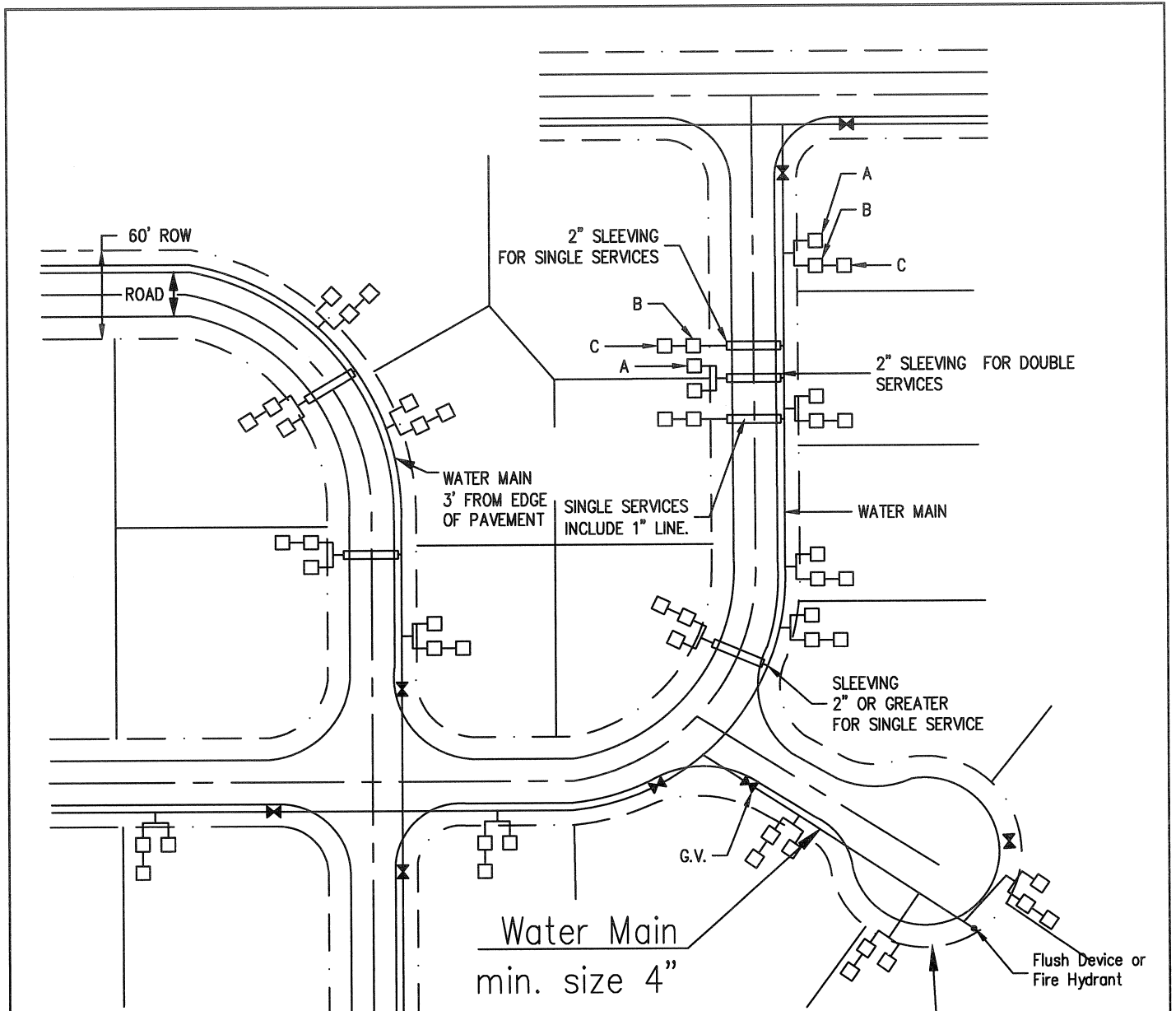

**KEY:**

- A = DOMESTIC METER
- B = IRRIGATION METER
- C = BACKFLOW ASSEMBLY

WHEN GRAVITY SEWER IS NOT WITHIN THE CUL-DE-SAC:  
 The water line must continue straight into the  
 cul-de-sac and terminate with a flushing device or  
 fire hydrant. no reduction in pipe size is allowed..

**NOTES:**

1. SINGLE SERVICES TO BE LOCATED AT CENTER OF LOT.
2. DOUBLE SERVICES TO BE LOCATED AT LOT LINE.
3. SINGLE SERVICES ONLY WHEN LOTS ARE A MINIMUM OF 2 ACRES OR IRRIGATION IS INSTALLED.
4. FLUSHING DEVICES ON CUL-D-SAC CAN EXTEND AROUND CURVE OR TERMINATE FROM STRAIGHT RUN.
5. DOUBLE SERVICES SHALL BE 1" DIAMETER MINIMUM AND SLEEVED WITH 2" PVC UNDER PAVED AREAS.

DRAWING NO.	W-20A
REVISION DATE	11/2018

TYPICAL WATER SYSTEM LAYOUT WITHOUT GRAVITY SEWER IN THE CUL-DE-SACs

**AQUA**

Aqua North Carolina, Inc.

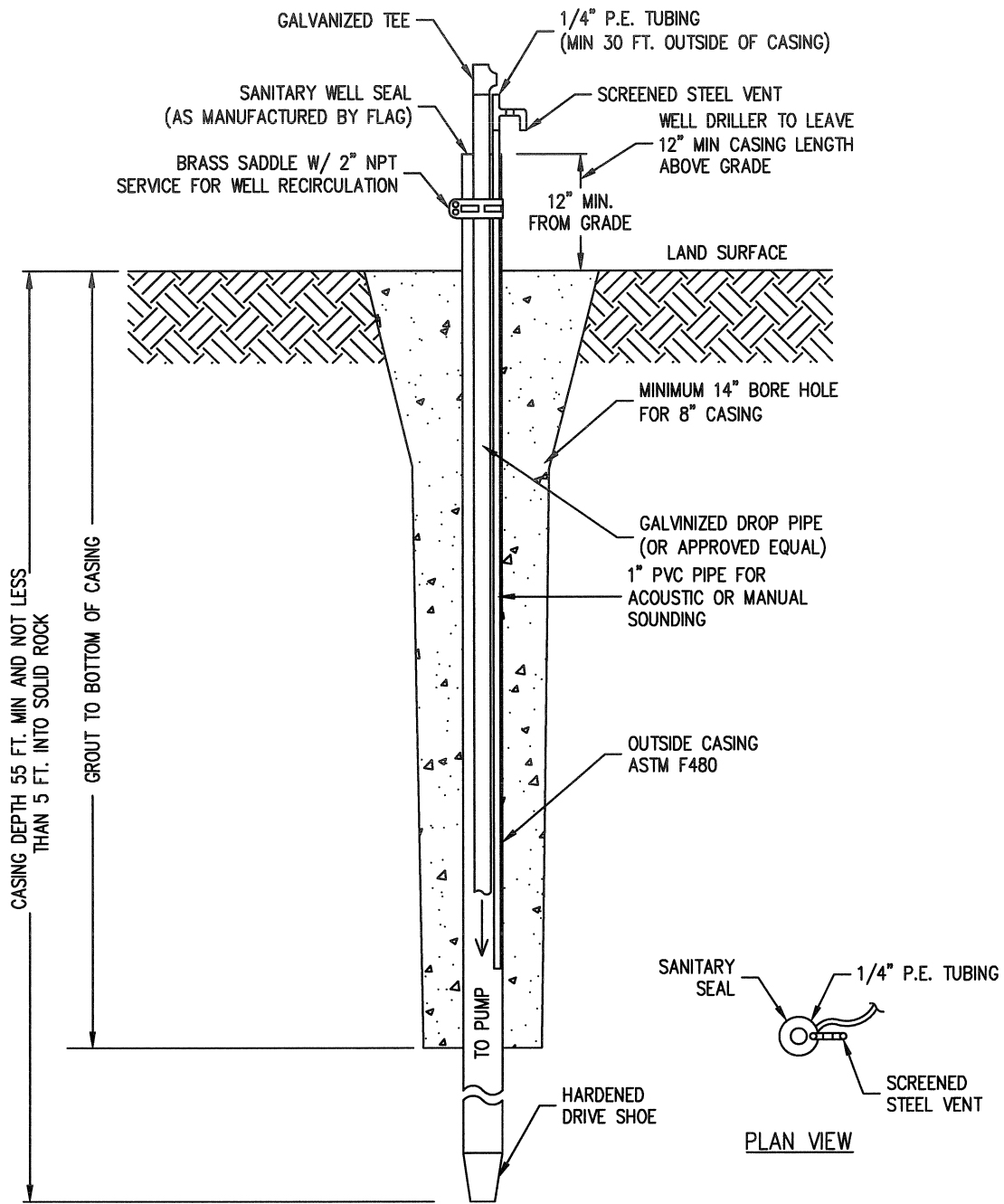

**NOTES:**

1. MOTORS SHALL BE MANUFACTURED BY FRANKLIN OR CENTRI-PRO AND OF THE HIGHEST PSI THRUST BEARING AVAILABLE.
2. PUMP SIZE AND TYPE SHALL BE DESIGNED AND SPECIFIED BY UTILITY.
3. SIMMONS SPRING CHECK VALVE SHALL BE INSTALLED AT THE PUMP,
4. THERE SHALL BE MINIMUM 20 FEET DROP CABLE OUTSIDE OF WELL.

DRAWING NO. W-21
REVISION DATE 02/2019

8" WELL DETAIL

**AQUA**

Aqua North Carolina, Inc.



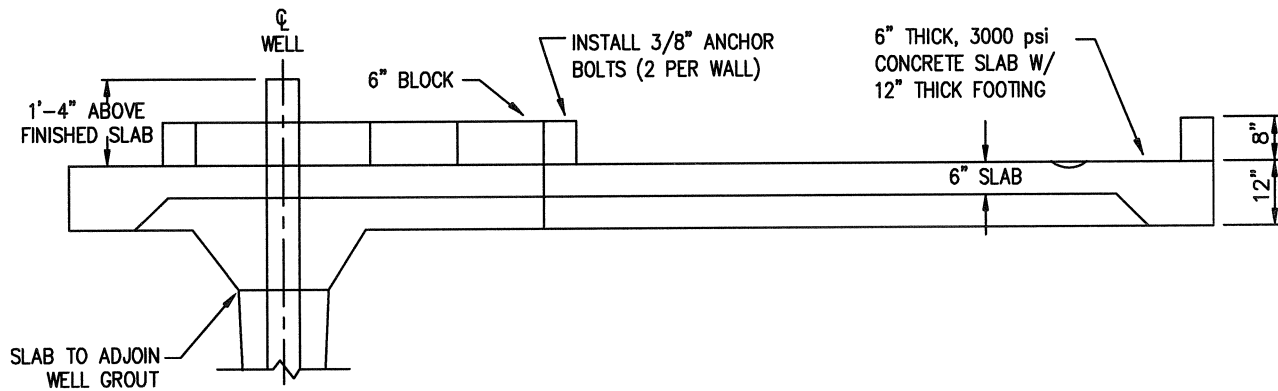
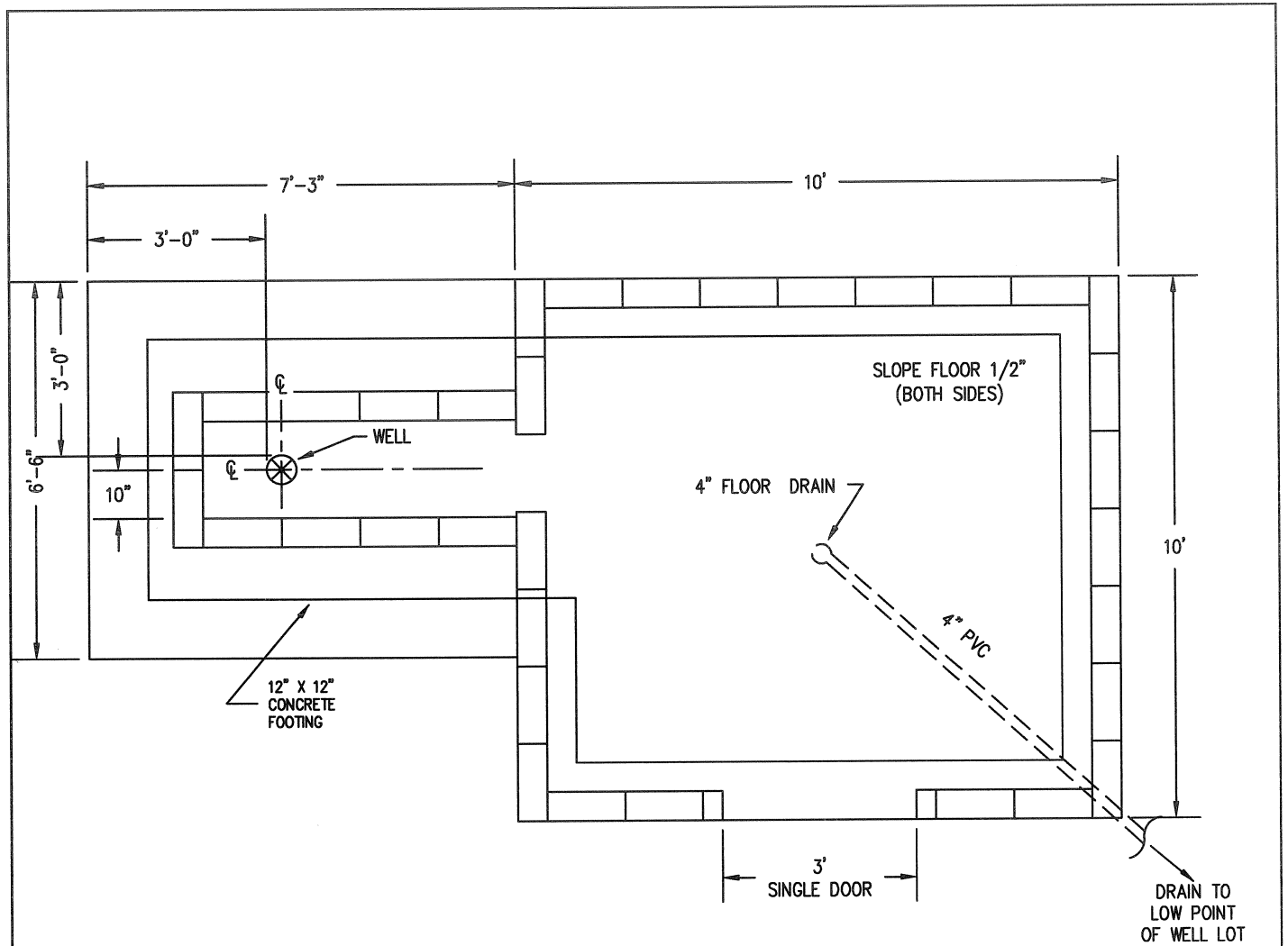

**NOTES:**

1. EDGES OF CONCRETE SLAB TO BE SMOOTH AND MINIMUM 4" ABOVE GRADE.
2. RUBBER TAPE OR ASPHALTUM REQUIRED AT CONCRETE/PIPE INTERFACE.

DRAWING NO. W-22
REVISION DATE 01/2017

WELL HOUSE FOUNDATION

**AQUA**  
Aqua North Carolina, Inc.

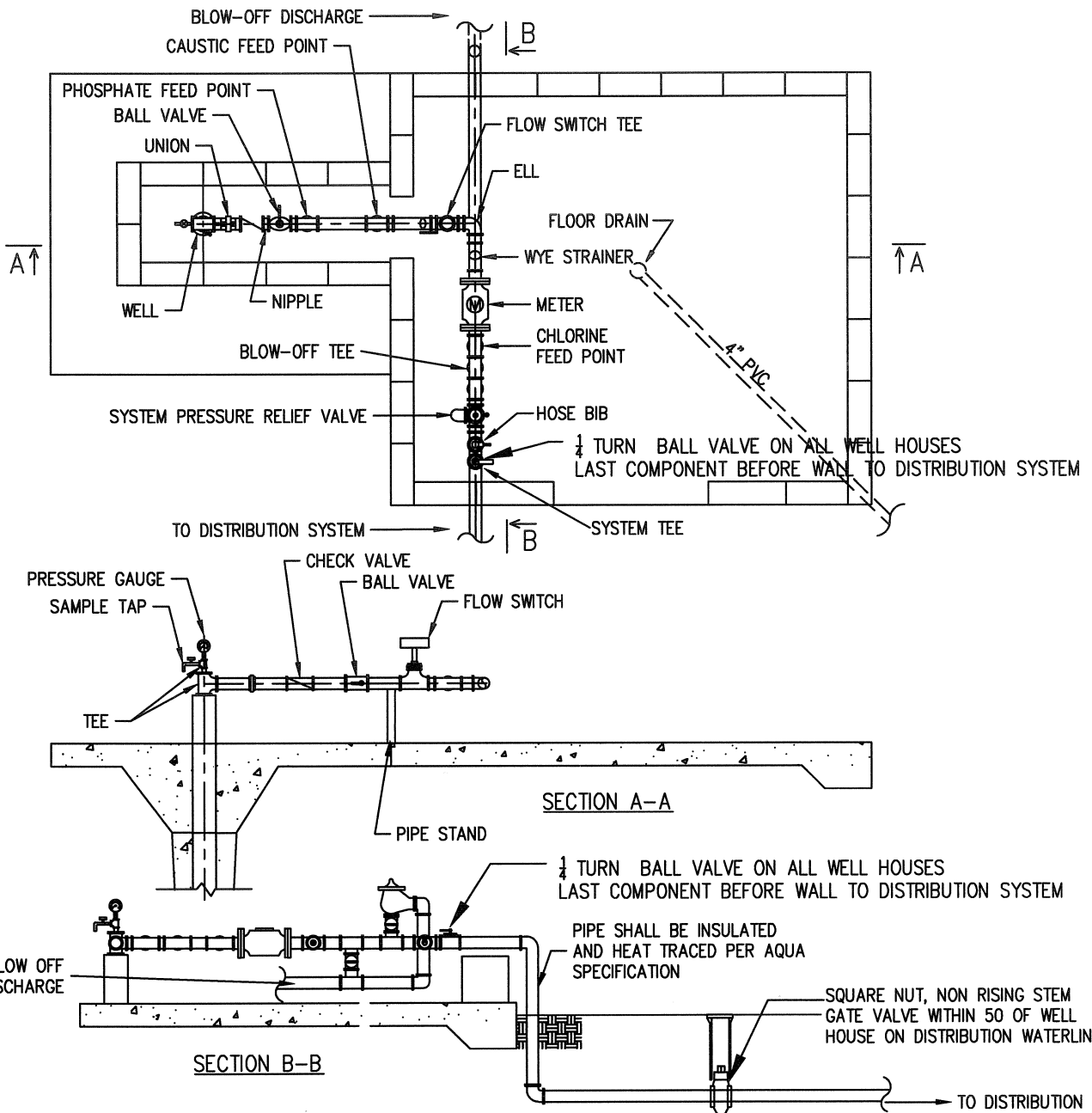

**NOTES:**

1. EDGES OF CONCRETE SLAB TO BE SMOOTH AND MINIMUM 4" ABOVE GRADE.
2. POSITION OF THROUGH SLAB PIPING AND CONDUIT TO BE VERIFIED WITH PIPE SIZE.
3. RUBBER TAPE REQUIRED AT CONCRETE/PIPE INTERFACE.

DRAWING NO.  
W-23

REVISION DATE  
4/2019

**WELL PIPING DETAILS**

**AQUA**

Aqua North Carolina, Inc.

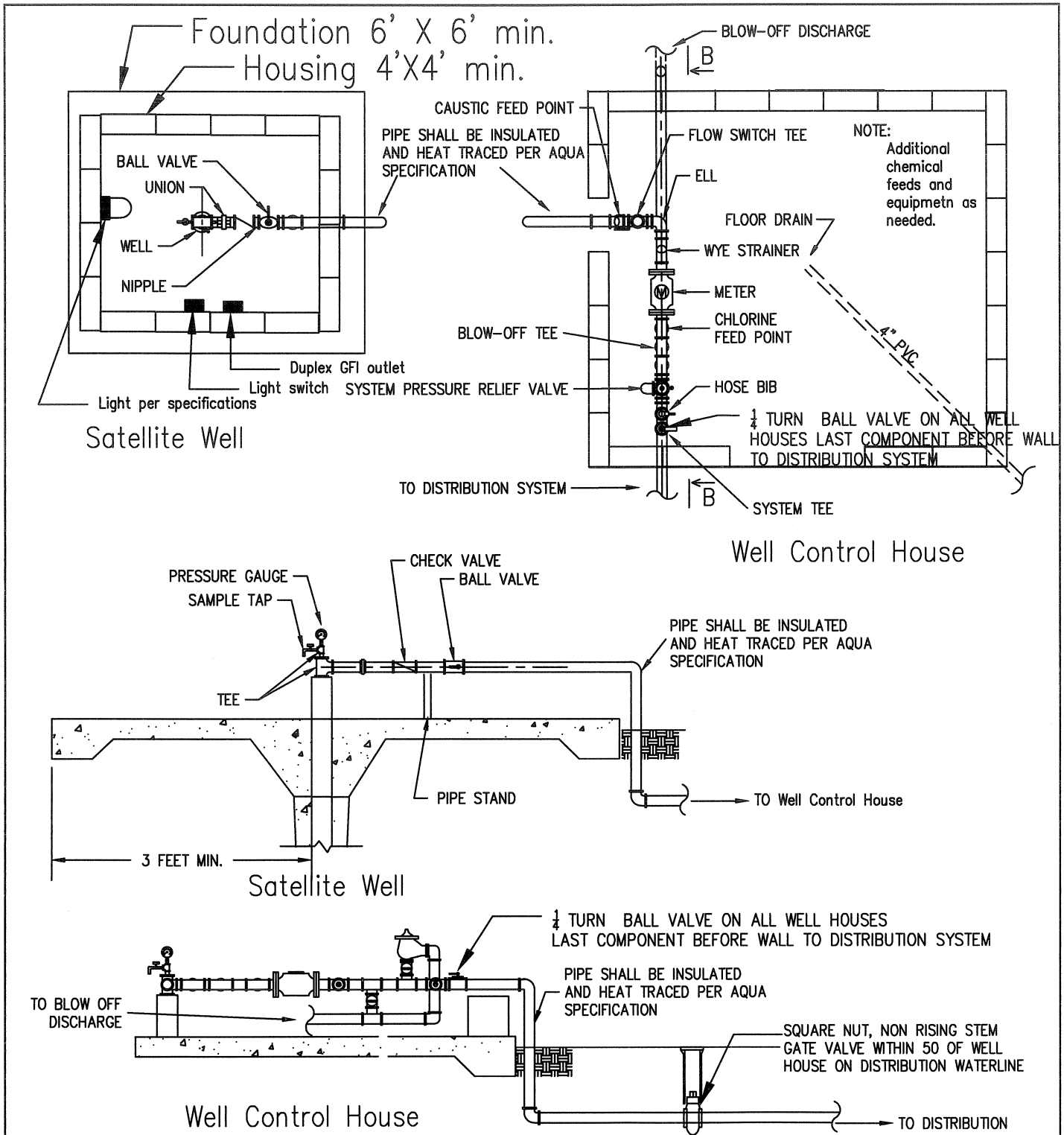

**NOTES:**

1. EDGES OF CONCRETE SLAB TO BE SMOOTH AND MINIMUM 4" ABOVE GRADE.
2. POSITION OF THROUGH SLAB PIPING AND CONDUIT TO BE VERIFIED WITH PIPE SIZE.
3. RUBBER TAPE REQUIRED AT CONCRETE/PIPE INTERFACE.
4. SATELLITE WELL HOUSE SHALL BE INSULATED AS SPECIFIED FOR THE MAIN WELL HOUSE.

DRAWING NO. W-23A
REVISION DATE 4/2019

SATELLITE WELL PIPING DETAILS

**AQUA**

Aqua North Carolina, Inc.

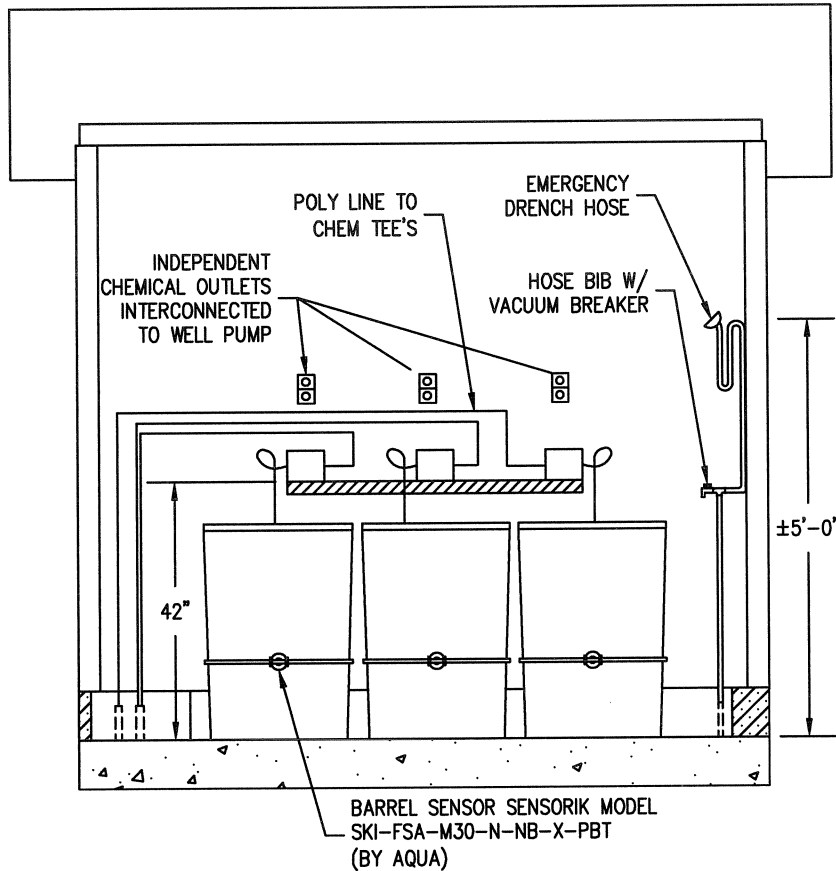
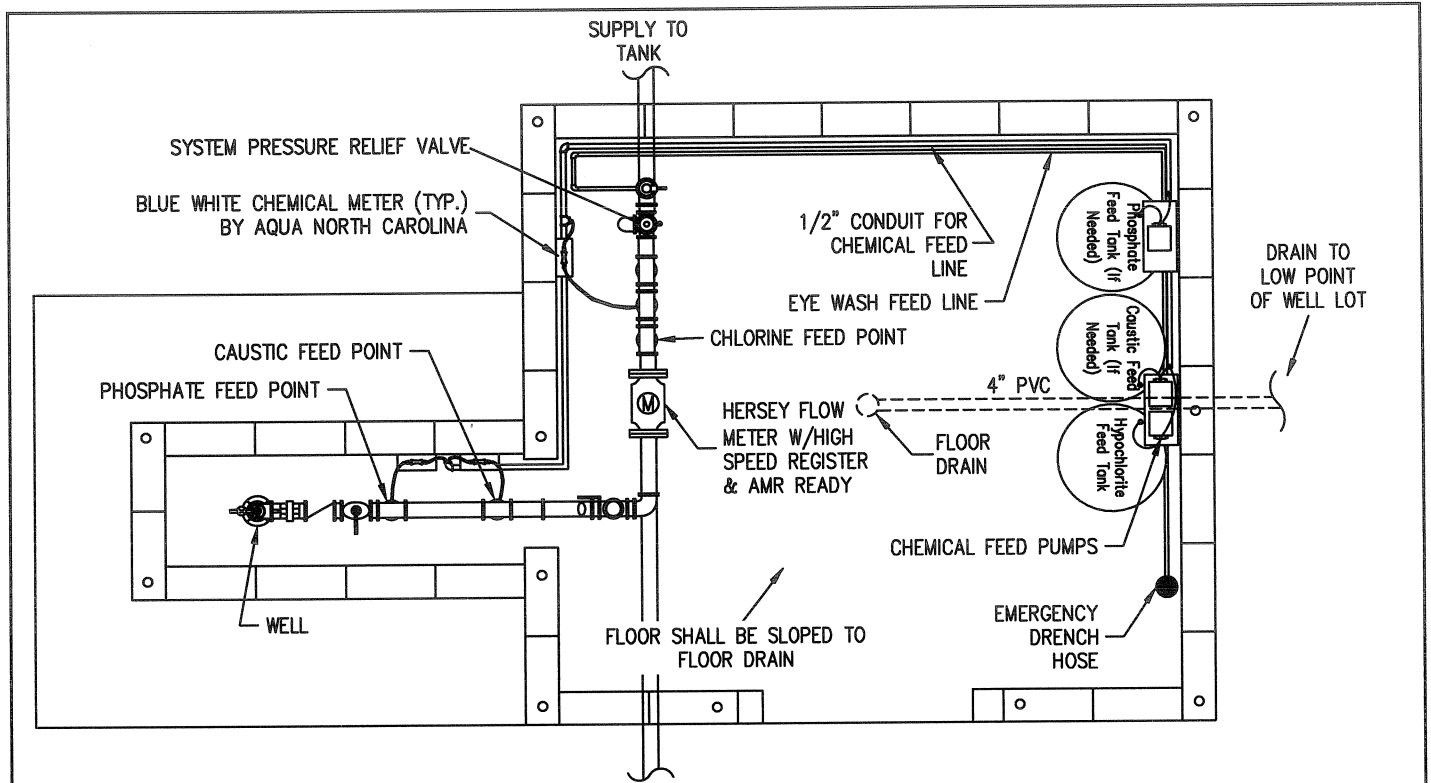

DRAWING NO.  
W-24

REVISION DATE  
12/2018

CHEMICAL DETAILS

**AQUA**

Aqua North Carolina, Inc.

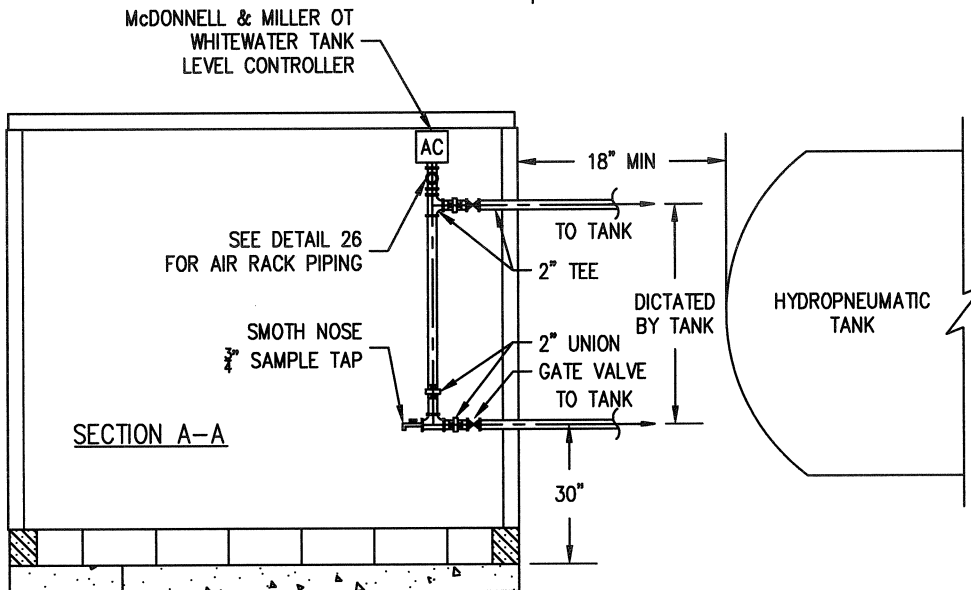
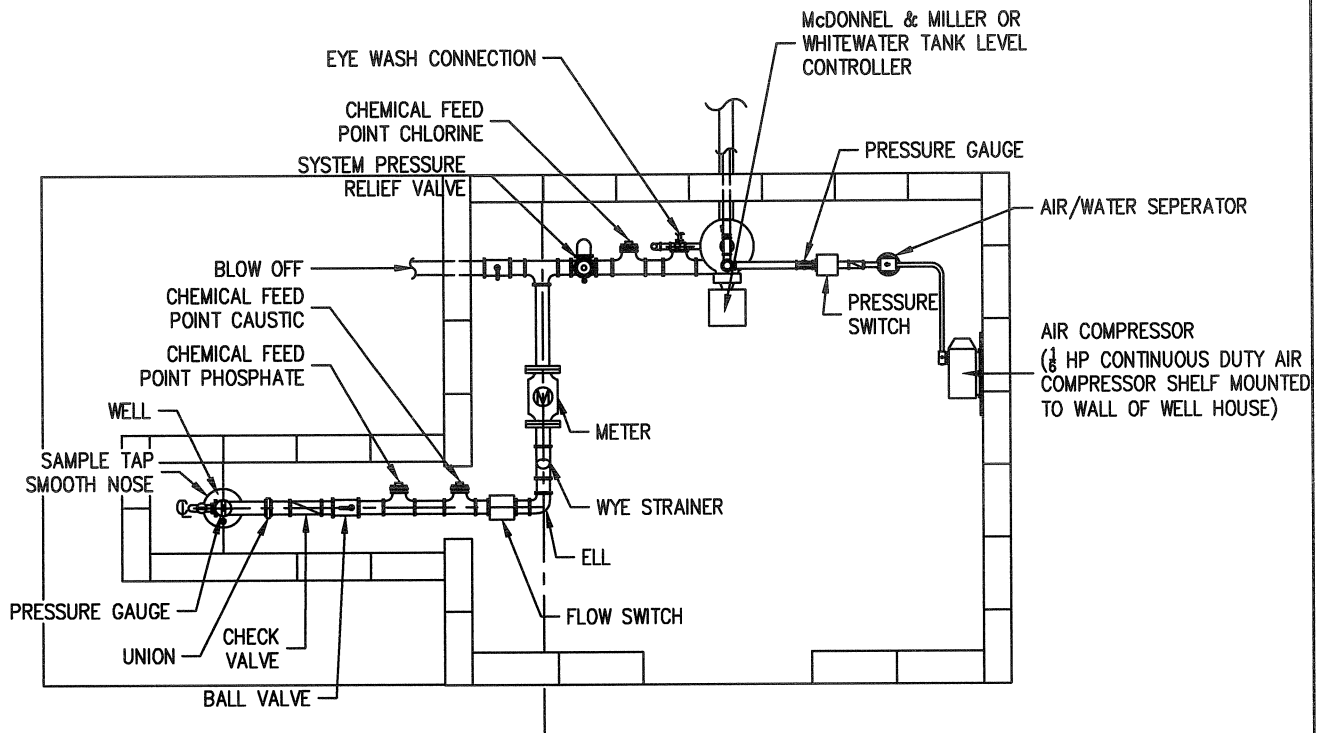

**NOTES:**

1. EDGES OF CONCRETE SLAB TO BE SMOOTH AND MINIMUM 4" ABOVE GRADE.
2. EXPOSED EXTERIOR PIPING SHALL BE HEAT TRACED AND INSULATED.
3. RUBBER TAPE REQUIRED AT CONCRETE/PIPE INTERFACE.
4. LAYOUT MAY BE SLIGHTLY DIFFERENT FOR McDONNELL & MILLER CONTROLLER.

DRAWING NO.  
W-25

REVISION DATE  
11/2018

WELL W/ TANK PIPING DETAILS

**AQUA**

Aqua North Carolina, Inc.

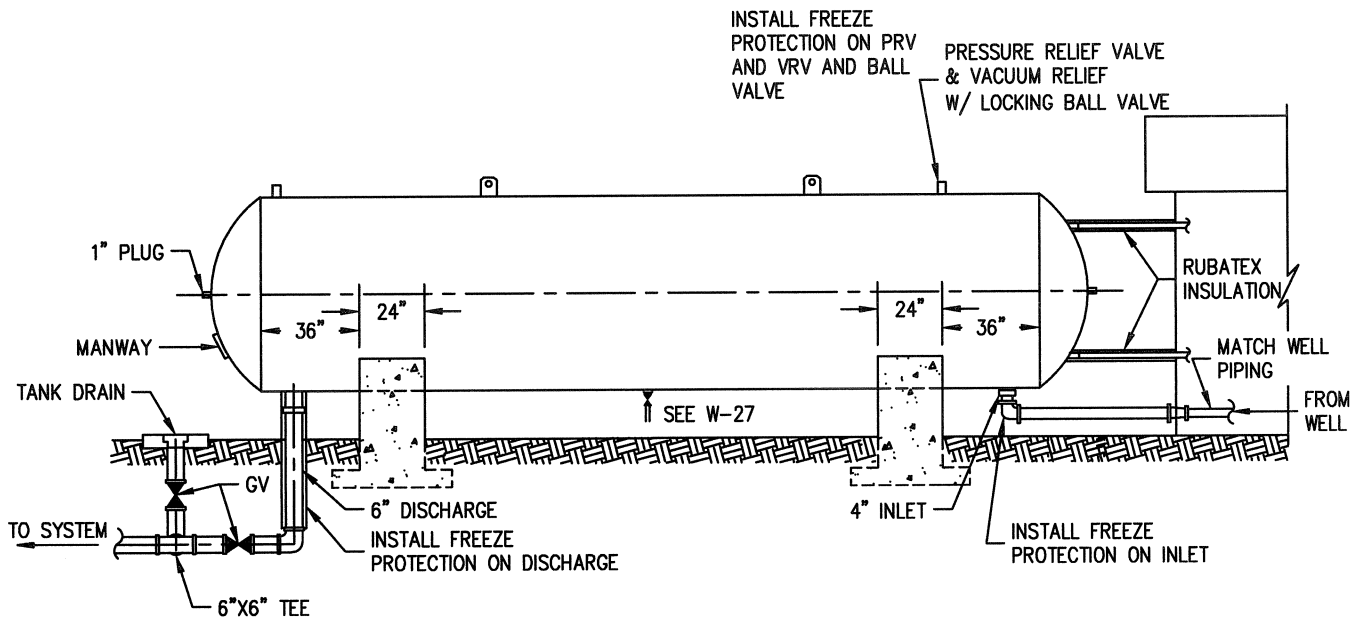
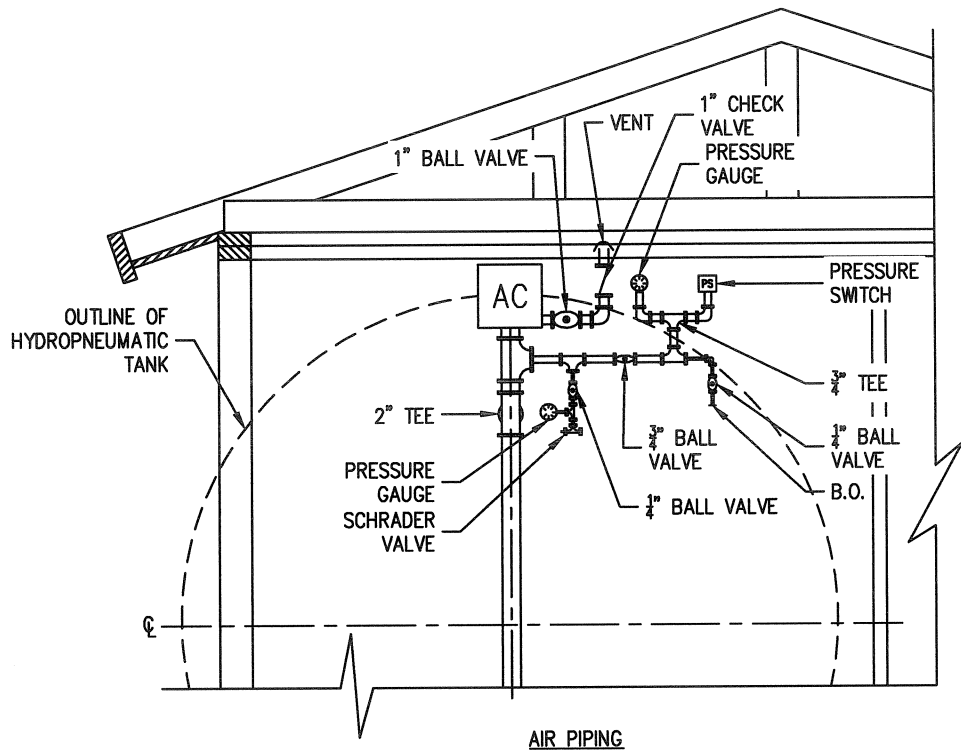

**NOTES:**

1. INSTALL RUBATEX INSULATION OVER ALL EXPOSED PIPING TO A DEPTH OF 36".
2. SEE DETAIL 26B FOR MCDONNELL & MILLER LAYOUT.

DRAWING NO. W-26	AIR PIPING & TANK PIPING DETAIL WHITEWATER LAYOUT	<b>AQUA</b> Aqua North Carolina, Inc.
REVISION DATE 11/2018		

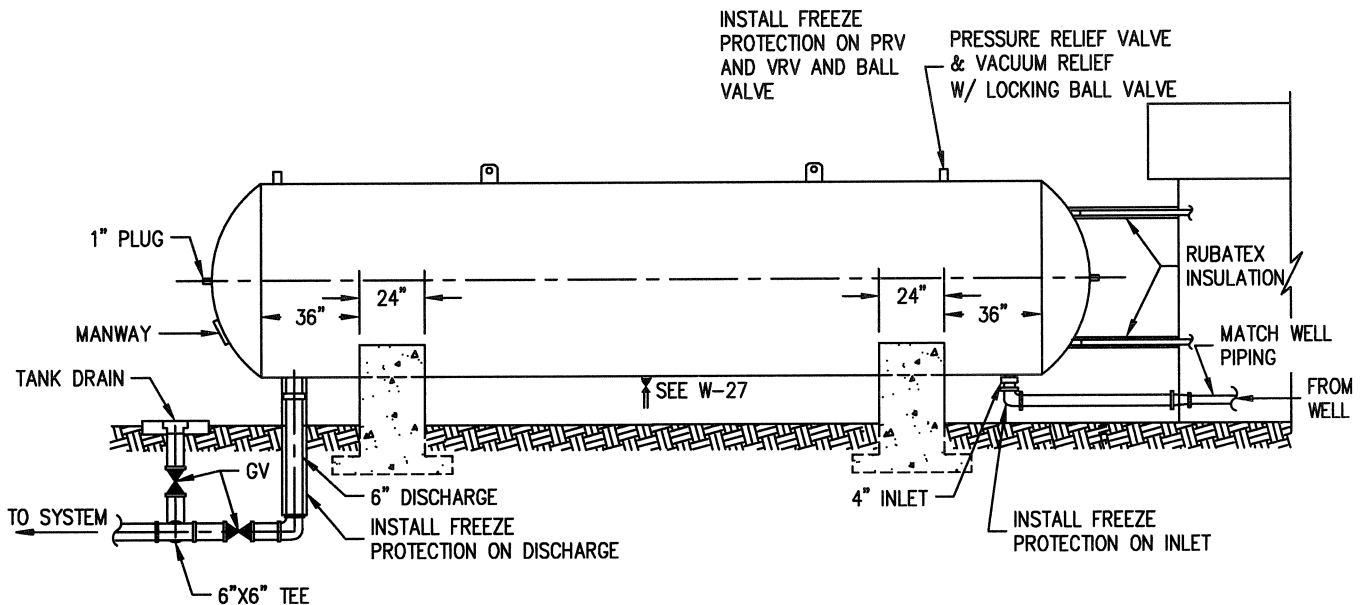
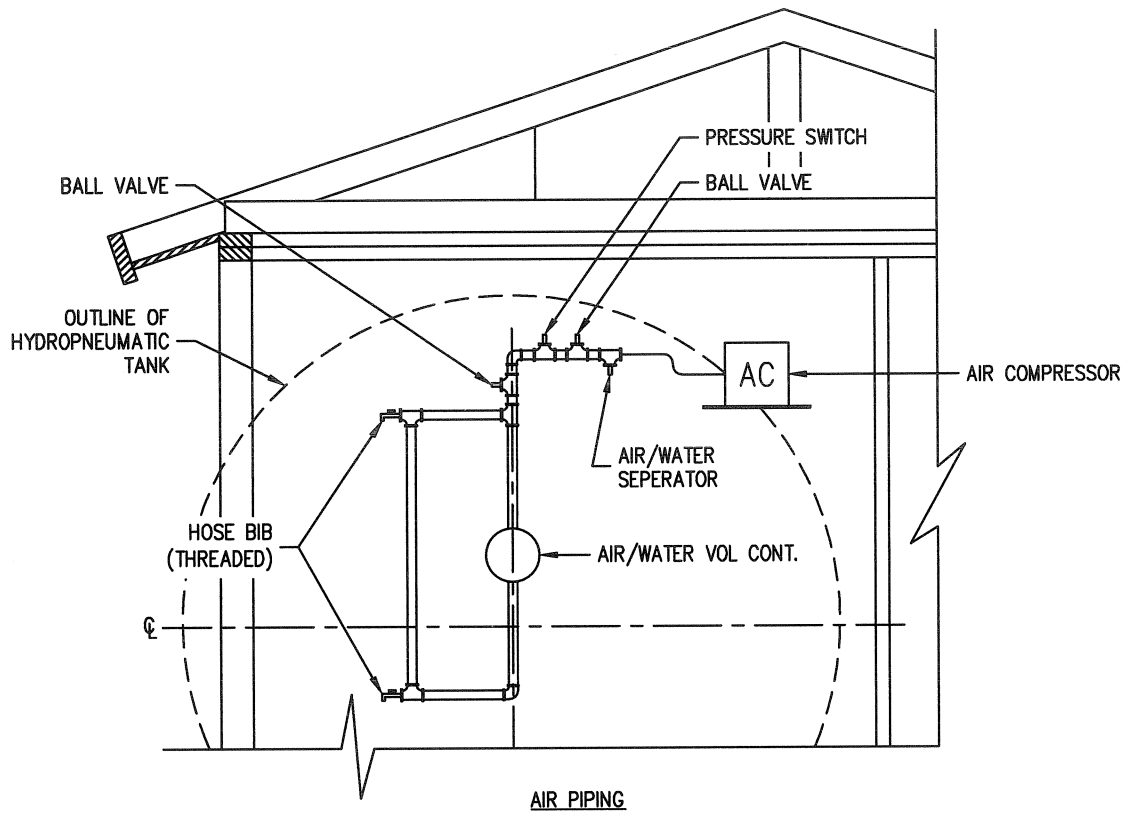

**NOTES:**

1. INSTALL RUBATEX INSULATION OVER ALL EXPOSED PIPING TO A DEPTH OF 36".
2. SEE DETAIL 26A FOR WHITWATER LAYOUT.

DRAWING NO. W-26A
REVISION DATE 11/2018

AIR PIPING & TANK PIPING DETAIL  
MCDONNELL & MILLER LAYOUT

**AQUA**  
Aqua North Carolina, Inc.

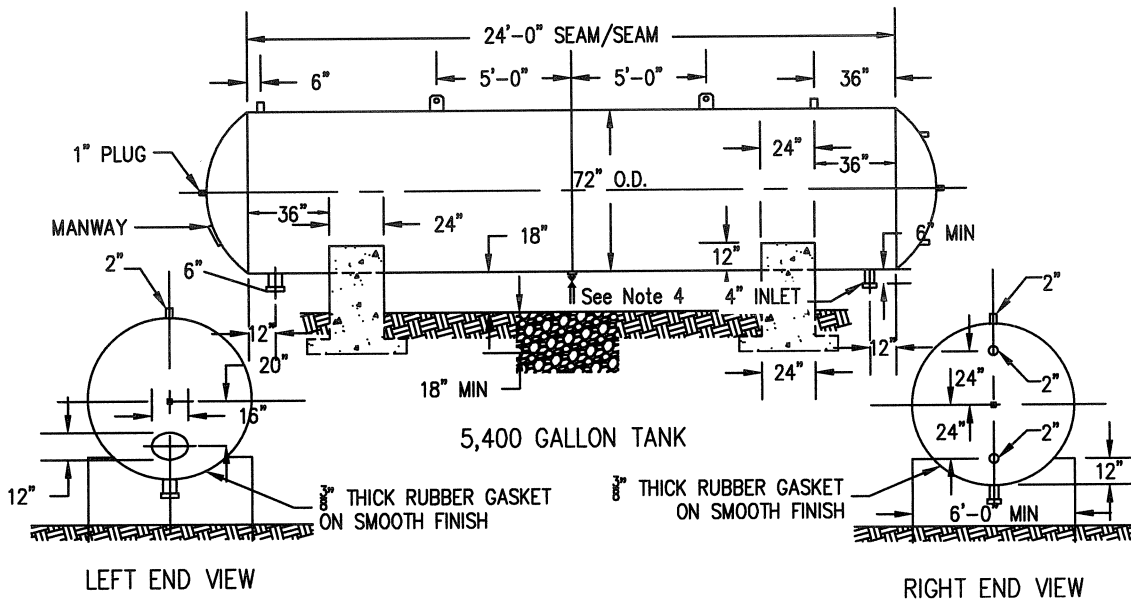
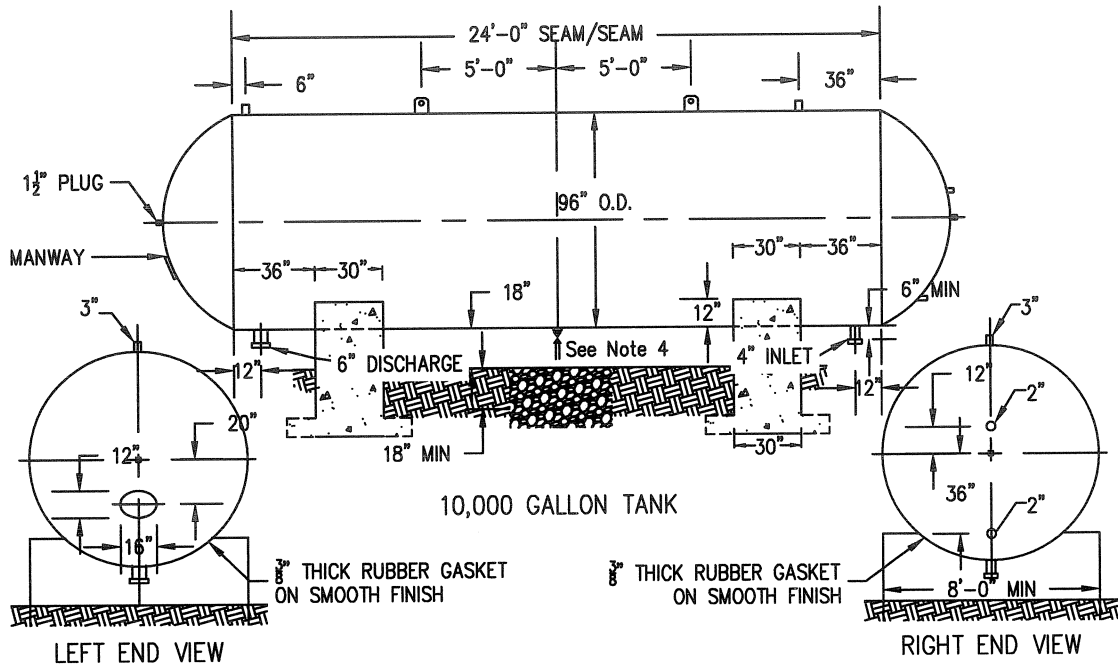

**NOTES:**

1. TANK SHALL BE ASME APPROVED AND HAVE MIN WORKING PRESSURE OF 125 psi.
2. PEDESTALS SHALL BE EXCAVATED TO SOLID COMPACT GROUND (18" MIN) AND POURED WITH 3,500 psi CONCRETE.
3. TANK BOTTOM TO BE PAINTED PRIOR TO SITTING ON 3/8" THICK RUBBER PEDESTAL GASKET.
4. TANKS SHALL HAVE A FACTORY INSTALLED TWO INCH BLOW-OFF LOCATED IN THE MIDDLE OF THE TANK LENGTHWISE AND AT THE ABSOLUTE BOTTOM (ZERO DEGREES). A WHEEL OPERATED TWO (2) INCH GATE VALVE WILL BE INSTALL WITH A NIPPLE EXTENDING NO CLOSER THAN 3 INCHES FROM THE FINAL GRADE (A 3 INCH AIR GAP SHALL BE MAINTAINED). ALL VALVES AND PIPING USED SHALL BE RATED AT A MINIMUM OF 150 PSI OR AT LEAST 25 PSI ABOVE THE RATED MAXIMUM TANK PRESSURE. CENTERED UNDERNEATH THIS BLOWOFF PIPE SHALL BE A 3 FOOT BY 3 FOOT WIDE WASHED STONE BED AT A MINIMUM OF 18 INCHES DEEP.

DRAWING NO. W-27
REVISION DATE 12/2018

HYDROPNEUMATIC TANK

**AQUA**

Aqua North Carolina, Inc.



STRUCTURAL GENERAL NOTES

**GENERAL NOTES:**  
 ALL DETAILS AND SECTIONS SHOWN ON THE DRAWINGS ARE INTENDED TO BE TYPICAL AND SHALL BE CONSIDERED TO APPLY TO ANY SIMILAR SITUATION ELSEWHERE ON THE PROJECT, EXCEPT WHERE A DIFFERENT DETAIL IS SHOWN.  
 MANUFACTURERS OF ANY PRE-ENGINEERED, PRE-FABRICATED SYSTEM OR COMPONENT SHALL SUBMIT SHOP DRAWINGS FOR THE ENGINEER/ARCHITECT'S APPROVAL PRIOR TO FABRICATION OR ERECTION OF SYSTEM/COMPONENT. THESE SHOP DRAWINGS SHALL BE SIGNED AND SEALED BY A NORTH CAROLINA REGISTERED ENGINEER.

**FOUNDATIONS:**  
 IT SHALL BE OWNER'S RESPONSIBILITY TO VERIFY SOIL BEARING CAPACITY AND SUB SURFACE CONDITIONS, PRIOR TO START OF CONSTRUCTION. OWNER'S GEOTECHNICAL CONSULTANT MAY RECOMMEND DIFFERENT SITE PREPARATION REQUIREMENTS THAN LISTED BELOW. CONTRACTOR SHALL COORDINATE SOIL INVESTIGATION FINDINGS AND SUBSEQUENT RECOMMENDATIONS WITH OWNER AND HIS GEOTECHNICAL CONSULTANT.

MAXIMUM ALLOWABLE SOIL PRESSURE IS ASSUMED TO BE 2000 POUNDS PER SQUARE FOOT.  
 SPREAD FOOTINGS SHALL BEAR ON SOIL COMPACTED TO A DENSITY OF AT LEAST 95% OF MODIFIED PROCTOR MAXIMUM DENSITY (A.S.T.M. D1557). THE SOIL SHALL BE COMPACTED TO THIS DENSITY TO A DEPTH OF AT LEAST TWO FEET BELOW THE BOTTOM OF THE FOOTINGS.

**CONCRETE:**  
 DESIGN OF REINFORCED CONCRETE CONFORMS WITH BUILDING CODE REQUIREMENTS FOR REINFORCED CONCRETE - ACI 318, LATEST EDITION.  
 CONCRETE SHALL HAVE AN UNCONFINED COMPRESSIVE STRENGTH OF 3000 PSI AT 28 DAYS.

CONCRETE PROTECTION FOR REINFORCING BARS SHALL BE AS FOLLOWS:  
 FOOTINGS 3" CLEAR, BOTTOM AND SIDES, 2" CLEAR, TOP WALLS 2" CLEAR, OUTSIDE FACE, 1-1/2" CLEAR, INSIDE FACE

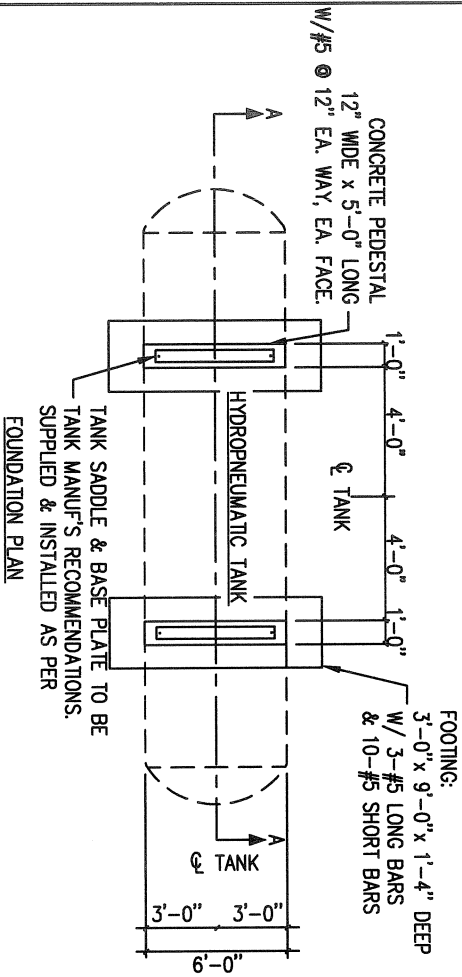
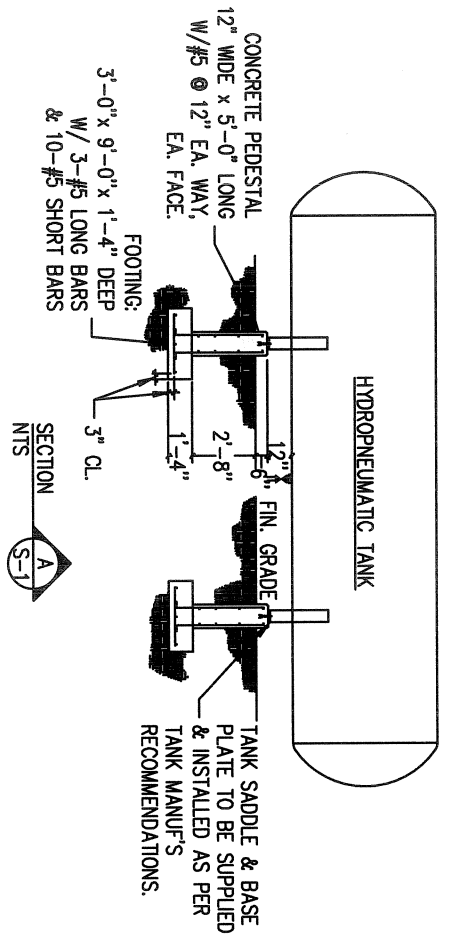

**DESIGN MIXES:**  
 PROVIDE NORMAL WEIGHT CONCRETE WITH THE FOLLOWING PROPERTIES:  
 3000 PSI 28-DAY COMPRESSIVE STRENGTH, 480 LBS. TYPE I PORTLAND CEMENT PER CU.YD. MINIMUM, W/C RATIO, 0.58 MAXIMUM (NON-AIR ENTRAINED), 0.46 MAXIMUM AIR ENTRAINED. NO FLY ASH OR OTHER POZZOLAN IS PERMITTED. SLUMP LIMIT 3" TO 5".

**REINFORCING STEEL:**  
 ALL REINFORCING STEEL SHALL BE NEW BILLET STEEL CONFORMING TO A.S.T.M. A615-GRADE 60. ALL DETAILING AND ACCESSORIES SHALL CONFORM TO TYPICAL DETAILS SHOWN IN THE "MANUAL OF STANDARD PRACTICE FOR DETAILING REINFORCED CONCRETE STRUCTURES ACI 315, LATEST EDITION".

**TANK:**  
 PRE-FABRICATED TANK MANUFACTURER SHALL SUBMIT SHOP DRAWINGS FOR DESIGN ENGINEER'S REVIEW PRIOR TO FABRICATION. FOLLOW ALL FEDERAL, STATE, AND LOCAL CODES AND OTHER ORDINANCES PERTAINING TO THIS WORK, PROVIDE ALL PERTINENT DETAILS, MATERIAL STRENGTH, PHYSICAL PROPERTIES, ETC. AS APPLICABLE.



Aqua North Carolina, Inc.

HYDROPNEUMATIC TANK DETAILS FOR STANDARD REPLACEMENT

DRAWING NO. W-28  
 REVISION DATE 12/2018

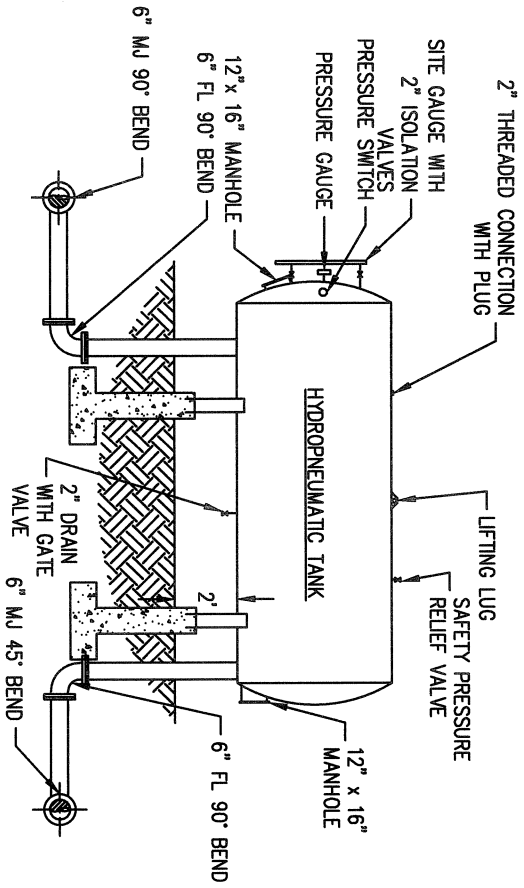
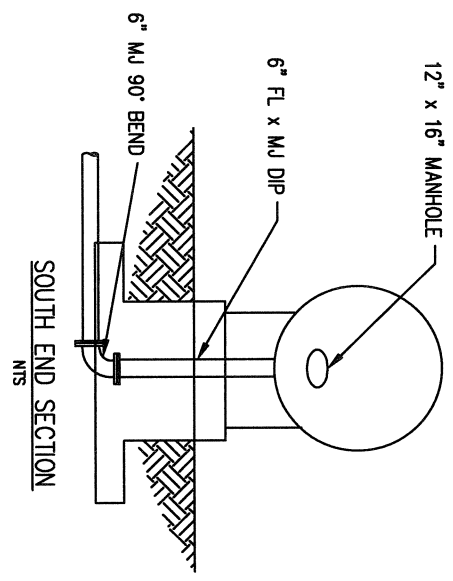
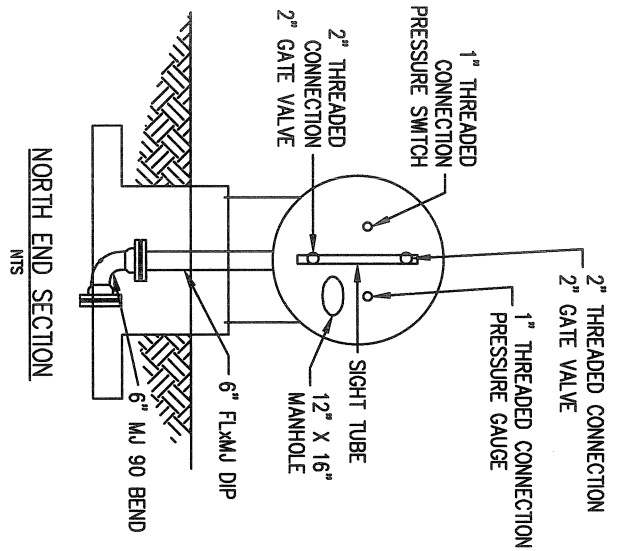

**NOTE:**  
 THE INTERIOR OF HYDRO-PNEUMATIC TANK SHALL BE  
 CLEANED & EPOXY COATED IN ACCORDANCE WITH THE EPA  
 AND NSF STANDARD 61 FOR POTABLE WATER SUPPLY  
 SYSTEM COMPONENTS.

DRAWING NO. W-29
REVISION DATE 12/2011

HYDROPNEUMATIC TANK DETAILS FOR STANDARD REPLACEMENT 2



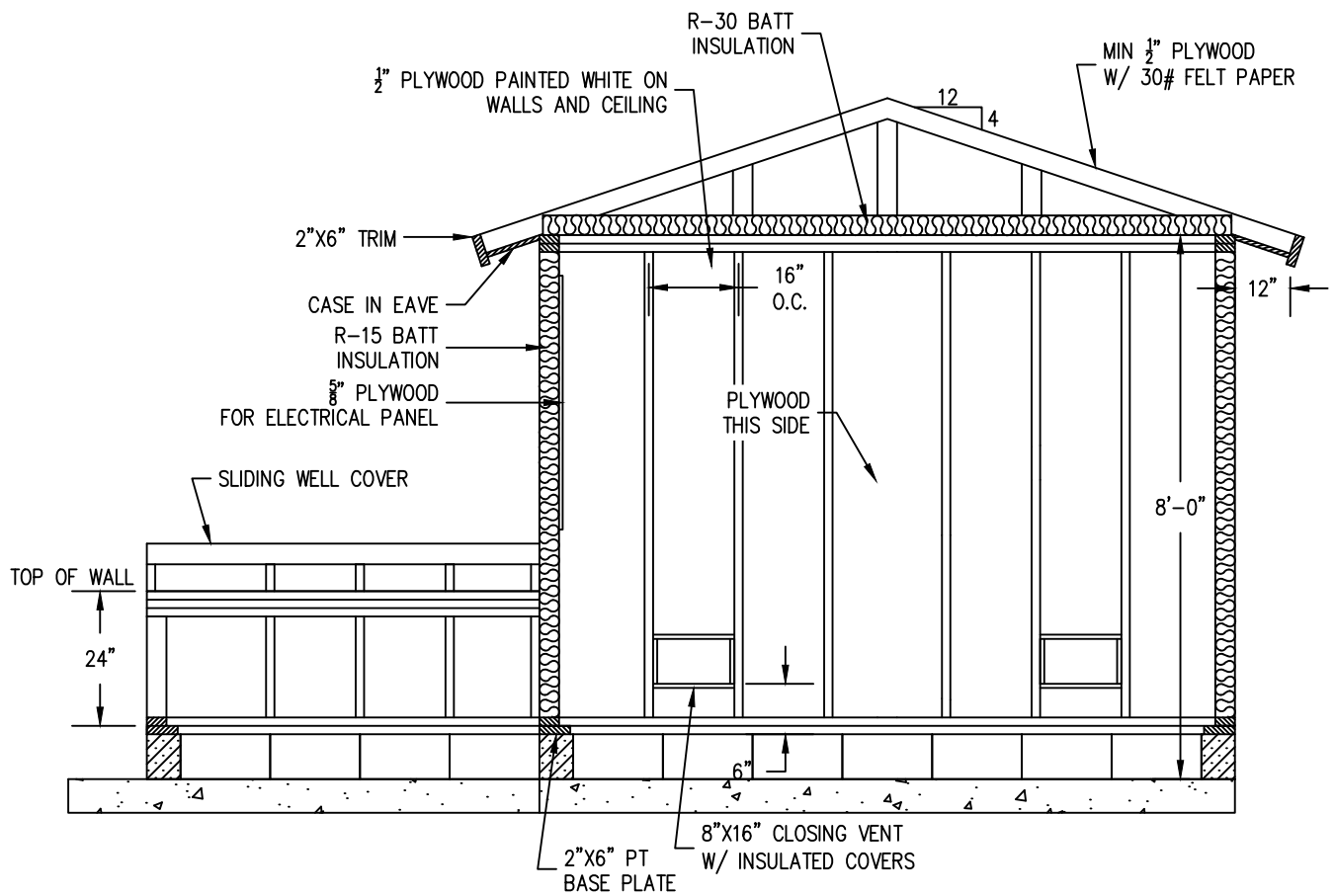

**NOTES:**

1. PROVIDE R-15 BATT INSULATION ON WALLS AND R-30 BATT INSULATION IN CEILING..
2. CEILING JOIST SHALL BE 8 FEET ABOVE FINISHED FLOOR.

DRAWING NO. W-30
REVISION DATE 01/2017

WELL HOUSE FRAMING DETAILS

**AQUA**

Aqua North Carolina, Inc.

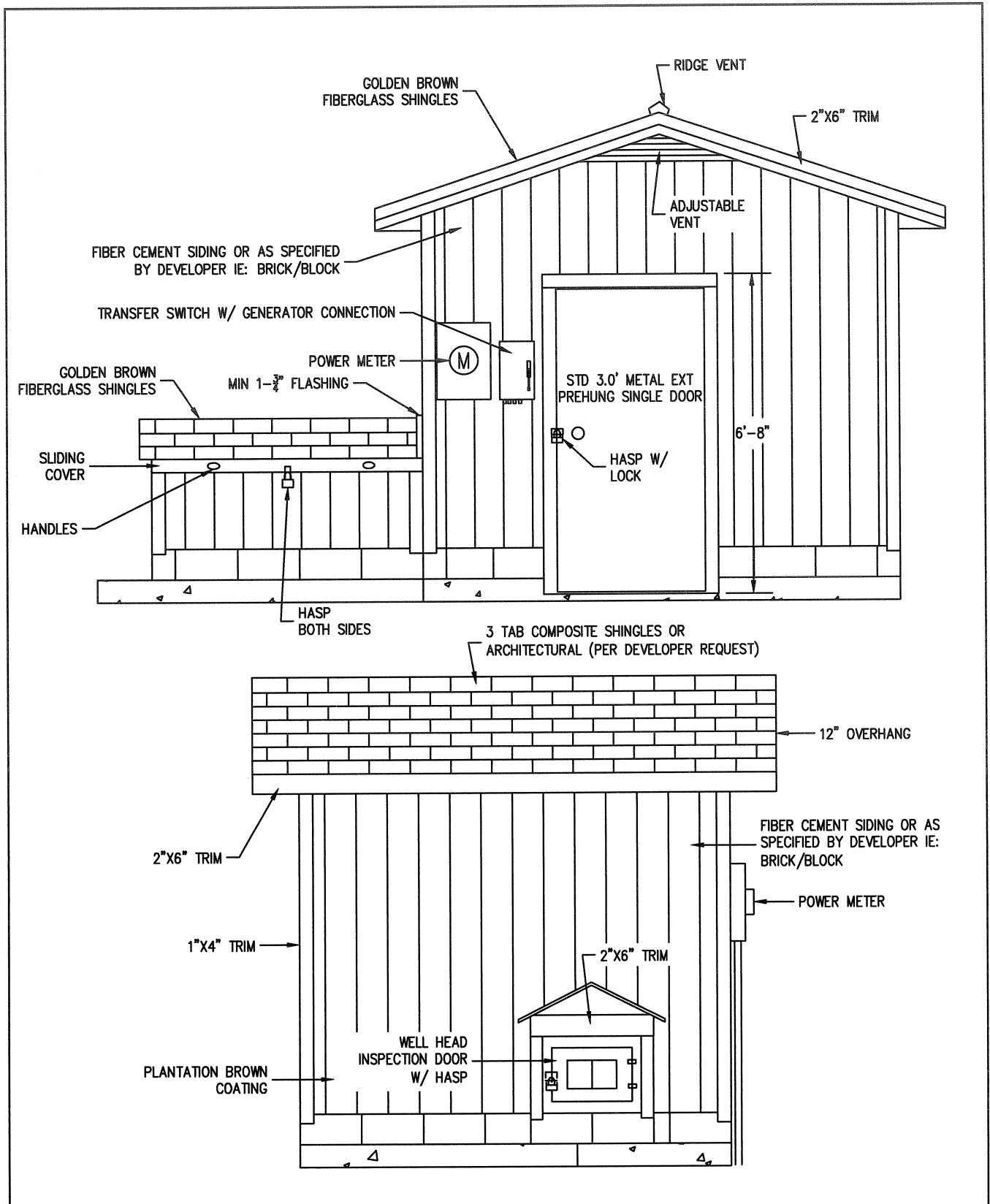

DRAWING NO.  
W-31

REVISION DATE  
11/2018

WELL HOUSE EXTERIOR DETAILS

**AQUA**

Aqua North Carolina, Inc.

3 INDIVIDUAL ELECTRICAL CIRCUITS FOR CHEMICAL FEED OUTLETS  
SERVED BY ONE CIRCUIT BREAKER

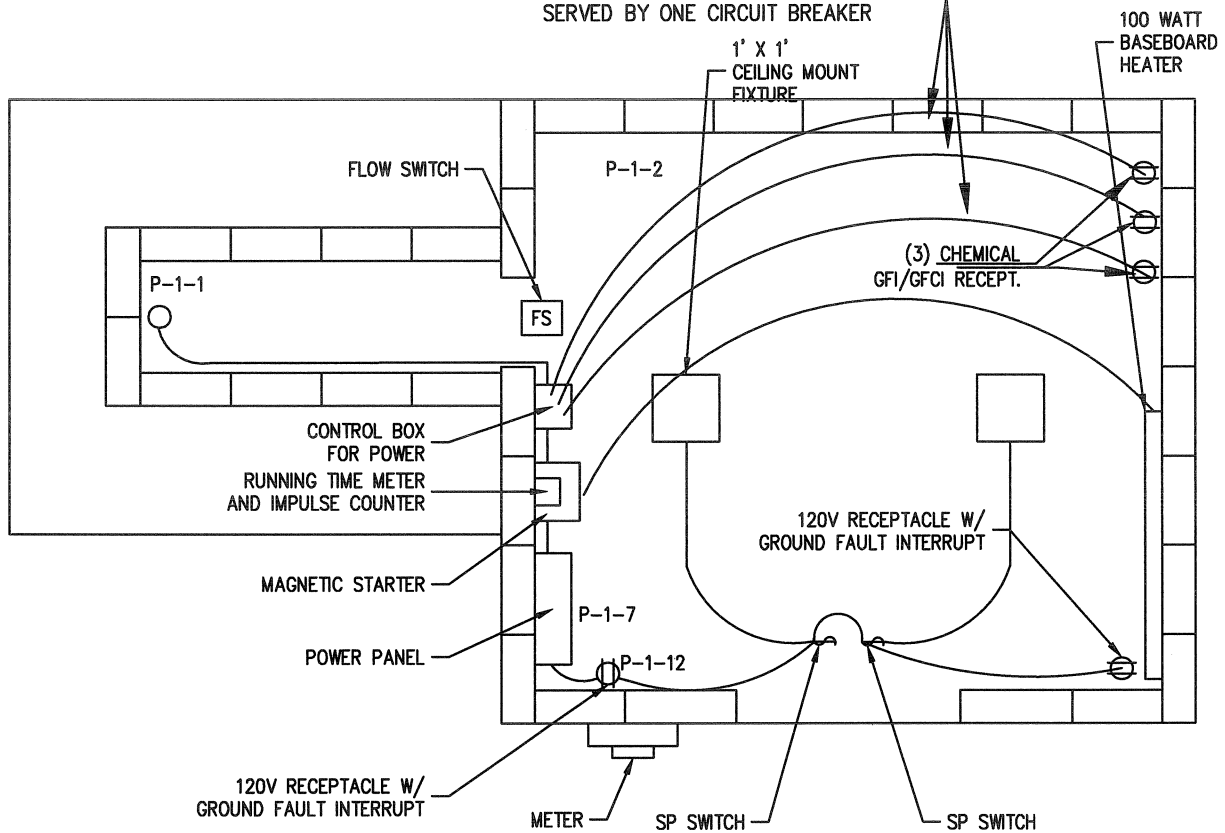

**NOTES:**

1. INSTALL REMOTE BULB THERMOSTAT FOR CONTROL OF BASEBOARD HEATERS.
2. LIGHT FIXTURES TO BE LSI LED FIXTURE MODEL EG34SLEDHOCWUSEL.
3. COPPER CONDUCTORS ARE REQUIRED.
4. STARTERS SHALL BE ALLEN BRADLEY, NEMA 3R, SERIES 509, THREE POLE WITH 120 VAC COIL.
5. SINGLE PHASE SYSTEMS SHALL HAVE FRANKLIN MOTOR CONTROL BOX INSTALLED.
6. PRESSURE SWITCH SHALL BE ALLEN BRADLEY 835T-T253J.
7. ELAPSE TIME METER SHALL BE VENDER-ROOT 7795.
8. IMPULSE COUNTER SHALL BE DURANT 6-Y-41345.

DRAWING NO.  
W-32

REVISION DATE  
03/2019

WELL HOUSE ELECTRICAL LAYOUT

**AQUA**

Aqua North Carolina, Inc.

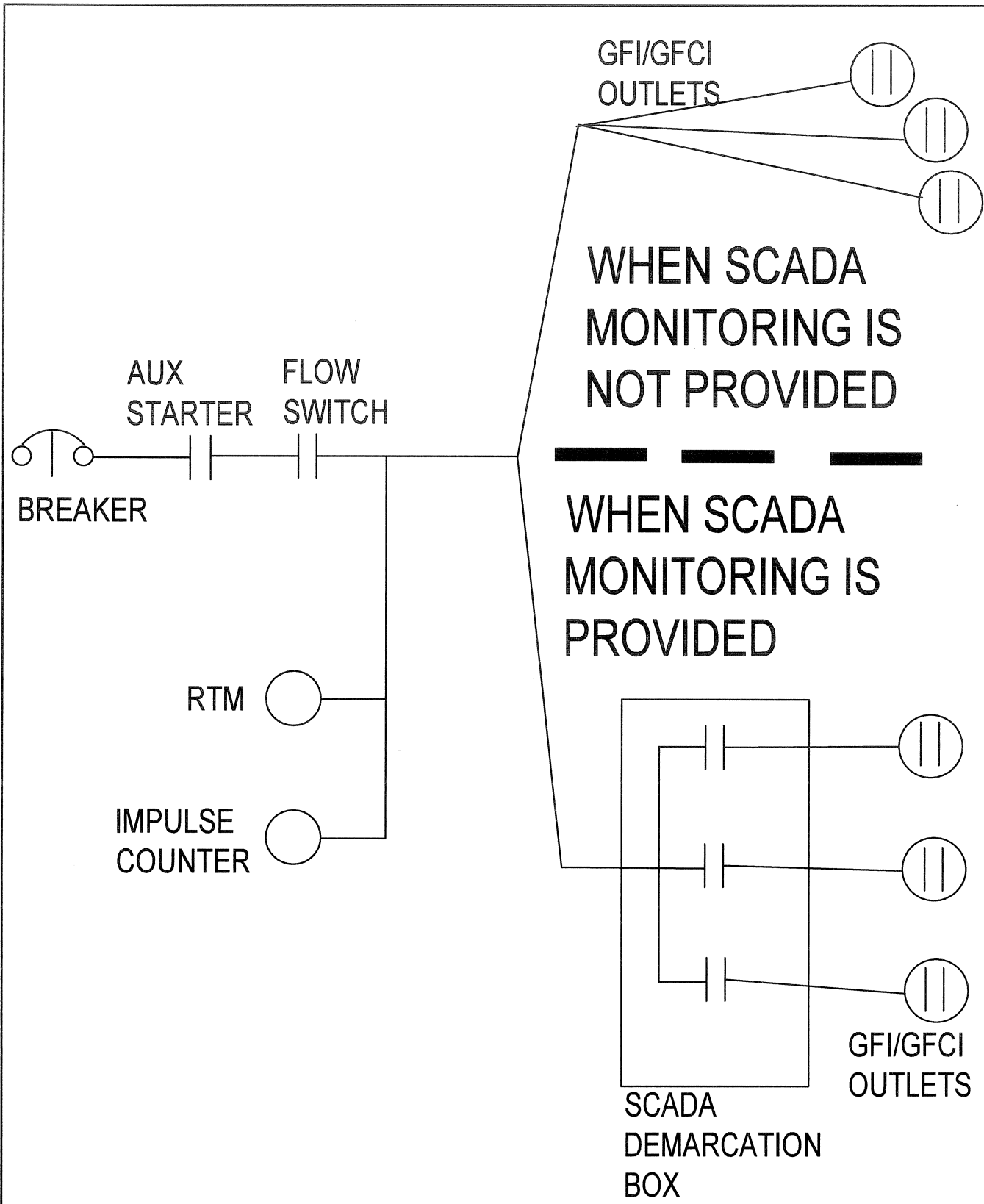

DRAWING NO. **W-32A**  
 REVISION DATE **3/2019**

**TYPICAL WELL HOUSE WIRING DIAGRAM**

**AQUA**  
 Aqua North Carolina, Inc.

# PANEL P-1

120/240V, 3  $\Phi$ , 4W  
200 AMP CB, SOLID NEUTRAL

DESCRIPTION	TRIP	CKT NO.	A B C	CKT NO.	TRIP	DESCRIPTION
PUMP (10-20 HP)	A.R.	1	●	2	20	1000 W BASEBOARD HEATERS (2)
		3	●	4		
		5	●	6		
CHEMICAL RECEPT.	15	7	●	8	20	AIR COMP. (HYDRO. TANKS ONLY)
*		9	●	10		*
SPARE		11	●	12	20	LIGHTS, RECEPT.
		13	●	14		
*		15	●	16		*
		17	●	18		
		19	●	20		

A.R. AS REQUIRED

\* CAUTION - DO NOT INSTALL ANY 120V CIRCUITS  
ON  $\Phi$ B - (HIGH LEG DELTA SYSTEM)

DRAWING NO.  
W-33

REVISION DATE  
12/2011

THREE PHASE PANEL LAYOUT

## AQUA

Aqua North Carolina, Inc.

# PANEL P-1

120/240V, 1  $\Phi$  3W  
200 AMP CB, SOLID NEUTRAL

DESCRIPTION	TRIP	CKT NO.	A	B	CKT NO.	TRIP	DESCRIPTION
PUMP (10-20 HP)	A.R.	1	●		2	20	1000 W BASEBOARD HEATERS (2)
		3		●	4		
CHEMICAL RECEPT.	15	5	●		6		SPACE
CONTROLS	15	7		●	8	20	AIR COMP. (HYDRO. TANKS ONLY)
SPARE	20	9	●		10	20	LIGHTS, RECEPT.
		11		●	12		
		13	●		14		
		15		●	16		

A.R. AS REQUIRED

DRAWING NO.  
W-34

REVISION DATE  
01/2017

SINGLE PHASE PANEL LAYOUT

**AQUA**  
Aqua North Carolina, Inc.



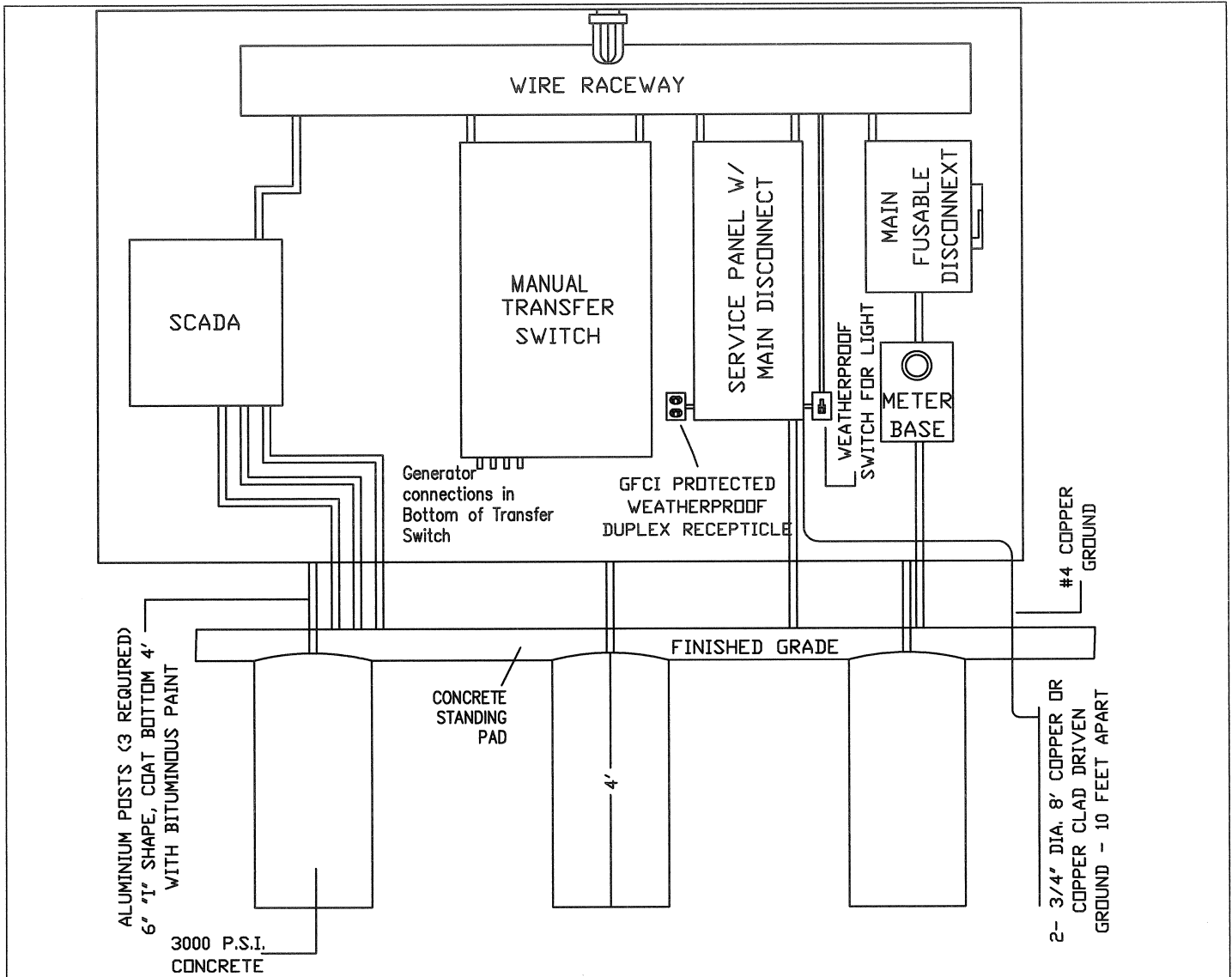

**\*NOTES\***

1. BACKING PLATE TO BE 1/4" ALUMINUM. MOUNT TO "I" BEAM POSTS WITH STAINLESS STEEL NUT, BOLTS, AND WASHERS.
2. ALL ELECTRICAL WORK SHALL CONFORM TO LATEST NATIONAL, STATE AND LOCAL CODES AND REQUIREMENTS.
3. SHOW CONDUIT SIZE AND NUMBER WITH WIRE SIZE AND NUMBER ON PUMP STATION PLANS.
4. PANEL LAYOUT IS SCHEMATIC ONLY. ADJUST AS NEEDED TO ACCOMMODATE EQUIPMENT.
5. ALL ENCLOSURES SHALL BE NEMA 4 RATED AND LOCKABLE.
6. ENCLOSURES SHALL BE MOUNTED TO ALUMINUM BACKING PLATE WITH NYLON SPACERS & STAINLESS STEEL NUTS, BOLTS & WASHERS.
7. ALL CONDUITS SHALL BE SEALED TO PREVENT MOISTURE, SEWER GASES, ETC. FROM ENTERING EQUIPMENT ENCLOSURES.
8. NO EQUIPMENT SHALL BE MOUNTED LESS THAN 36" ABOVE FINISHED GRADE.

FOR PANEL COVER  
SEE W-36

DRAWING NO. **W-35**  
REVISION DATE

Typical Satellite Well Electrical Panel

**AQUA**

Aqua North Carolina, Inc.

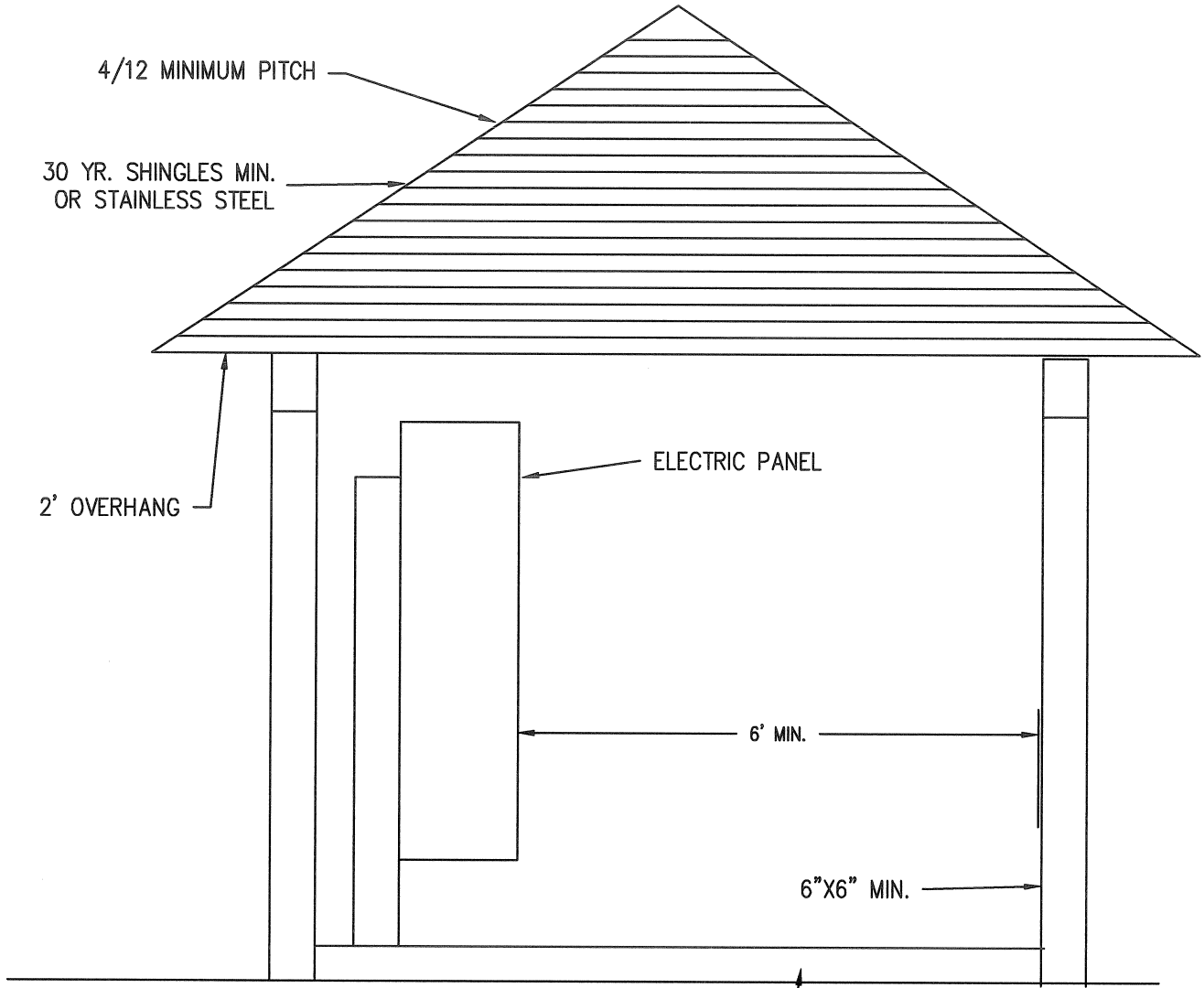

END VIEW

4 INCHES OF CONCRETE POURED ABOVE FINAL GRADE

NOTES:

1. ALL MATERIAL SHALL BE WOOD TREATED FOR GROUND CONTACT OR STAINLESS STEEL
2. MATERIALS SHALL BE IN ACCORDANCE TO BUILDING CODE

DRAWING NO. W-36

REVISION DATE

Typical Satellite Well Electrical Panel Cover

**AQUA**

Aqua North Carolina, Inc.

# **APPENDIX H – AQUA NC SPECIFICATIONS FOR WATER SYSTEMS**



# Specifications for Water Systems

(NC PWSS Approval Serial Number 19-00908)

## June 2019 Update

202 MacKenan Court  
Cary, North Carolina 27511  
919-467-8712

4163 Sinclair Street  
Denver, North Carolina 28037  
704-489-9404

6902 Sandridge Dr.  
Fayetteville, North Carolina 28314  
910-867-1239

152-B Furlong Industrial Dr.  
Kernersville, North Carolina, 27284  
336-889-6318

105 Hampstead Village, Bldg 24-I  
Hampstead, North Carolina 28443  
910-791-4404

# **AQUA NORTH CAROLINA**

## **Community Water System Specifications and Construction Standards**

### **Table of Contents**

<b>DIVISION 1</b>	<b>GENERAL REQUIREMENTS</b>
Section 1	Definitions
Section 2	Plan Review, Approval, Construction and Acceptance of Water Improvements
<b>DIVISION 2</b>	<b>DESIGN STANDARDS</b>
Section 1	Aqua North Carolina Daily Flows
Section 2	Well Sites
Section 3	Design Criteria for Pumps & Motors
Section 4	Water Treatment
Section 5	Water Mains & Appurtenances
<b>DIVISION 3</b>	<b>CONSTRUCTION SPECIFICATIONS</b>
Section 1	General
Section 2	Well Site Preparation
Section 3	Wells
Section 4	Plumbing
Section 5	Storage Tanks
Section 6	Well House
Section 7	Painting
Section 8	Electrical
Section 9	Excavation, Backfill, Compaction, Grading and Restoration
Section 10	Boring and Jacking
Section 11	Pressure Pipe Restraint
Section 12	Connections to Pressure Mains
Section 13	Pipe Material for Water Mains and Service Connections
Section 14	Water Main Installation, Disinfection and Pressure Testing
Section 15	Valves, Hydrants & Accessories
<b>DIVISION 4</b>	<b>STANDARD DETAILS</b>
<b>DIVISION 5</b>	<b>LIST OF MATERIALS AND APPROVED MANUFACTURERS</b>
Section 1	North Carolina

# INTRODUCTION

## **Jurisdiction**

This MANUAL shall apply to all proposed water systems and assets to be owned, operated or maintained by AQUA NORTH CAROLINA.

## **Purpose**

These standards and specifications are adopted to establish minimum acceptable standards for the design and construction of water distribution/transmission facilities that are to be dedicated to AQUA NORTH CAROLINA or facilities that interconnect to other utilities. Such facilities include water supply, distribution, and miscellaneous related appurtenances associated with such systems. These standards and specifications apply only to approval by AQUA NORTH CAROLINA and not by any state or local authorities.

It is the responsibility of the design ENGINEER to ensure that this specification and/or his amendments (as approved by AQUA NORTH CAROLINA) meet all applicable building codes and governing laws.

Approval by AQUA NORTH CAROLINA does not relieve the ENGINEER from obtaining approval from state or local authorities.

## **Scope**

This document is grouped into five divisions:

Division 1: General Requirements, presents general requirements governing review and approval of plans and construction inspection and acceptance.

Division 2: Design Standards contains all the criteria required for the acceptable design of water mains.

Division 3: Construction Specifications, contains detailed technical specifications governing the construction of water facilities.

Division 4: Standard Details, consists of drawings showing typical installation/construction of water facilities.

Division 5: List of Materials and Approved Manufacturers consists of approved equipment for construction per region.

# **DIVISION 1**

## **GENERAL REQUIREMENTS**

# Division 1

## Section 1

### Definitions

#### 1.1 Definitions

Except where specific definitions are used within a specific section, the following terms, phrases, words and their derivations shall have the meaning given herein when consistent with the context. Words used in the present tense include the future tense, words in the plural number include the singular number and words in the singular number include the plural number. The word "shall" is mandatory, and the word "may" is permissive.

AASHTO - American Association of State Highway and Transportation Officials. Any reference to AASHTO standards shall be taken to mean the most recently published revision unless otherwise specified.

ANSI - American National Standards Institute. Any reference to ANSI standards shall be taken to mean the most recently published revision unless otherwise specified.

ASTM - American Society for Testing Materials. Any reference to ASTM standards shall be taken to mean the most recently published revision unless otherwise specified.

AWWA - American Water Works Association. Any reference to AWWA Standards shall be taken to mean the most recently published revision unless otherwise specified.

CONTRACTOR - the person, firm, or corporation with whom the contract for work has been made by the Owner, the Developer or AQUA NORTH CAROLINA.

COUNTY - the applicable county and/or its designated representative(s).

DEVELOPER - the person, firm or corporation engaged in developing or improving real estate for use or occupancy.

DEVELOPER'S ENGINEER - an engineer or engineering firm registered with the State of North Carolina Board of Examiners for Engineers & Surveyors, retained by the DEVELOPER to provide professional engineering services for a project.

DIPRA - Ductile Iron Pipe Research Association. Any reference to DIPRA standards shall be taken to mean the most recently published revision unless otherwise specified

DRAWINGS - engineering drawings prepared by an ENGINEER to show the proposed construction.

ENGINEER - an engineer or engineering firm registered with the North Carolina Board of Examiners for Engineers & Surveyors.



FM - Factory Mutual. Any reference to FM standards shall be taken to mean the most recently published revision unless otherwise specified

GEOTECHNICAL/SOILS ENGINEER - a Registered North Carolina Engineer who provides services related to terrain evaluation and site selection, subsurface exploration and sampling, determination of soil and rock properties, foundation engineering, settlement and seepage analysis, design of earth and earth retaining structures, the design of subsurface drainage systems and the improvement of soil properties and foundation conditions and testing and evaluation of construction materials.

MANUAL - these Specifications for Water Construction.

MANUAL ON UNIFORM TRAFFIC CONTROL DEVICES - the United States Department of Transportation Manual on Traffic Control Devices, latest edition.

NCBELS – The North Carolina Board of Examiners for Engineers and Surveyors

NCDEQ – the North Carolina Department of Environmental Quality

NCDOT - the North Carolina Department of Transportation

NEMA - National Electrical Manufacturers Association. Any reference to NEMA Standards shall be taken to mean the most recently published revision unless otherwise specified.

NSF - National Sanitation Test Laboratory Foundation. Any reference to NSF Standards shall be taken to mean the most recently published revision unless otherwise specified.

OSHA - the Federal Occupational Safety and Health Administration.

OWNER - the person, firm, corporation, or governmental unit holding right of possession of the real estate upon which construction is to take place.

PLANS - DRAWINGS as defined herein above.

PWS – NCDENR Public Water Supply Section

RULES GOVERNING PUBLIC WATER SYSTEMS: North Carolina Administrative Code, Title 15a, Department of Environment and Natural Resources, Subchapter 18C – Water Supplies – Sections .0100 through .2200, latest edition.

SPECIFICATIONS - the specifications contained in Division 3 of this MANUAL.

STANDARDS - the minimum design standards contained in Division 2 of this MANUAL.

STANDARD DETAILS - the detailed drawings in Division 4 of this MANUAL related to water materials and installation of same.

SURVEYOR - a surveyor or surveying firm registered with the North Carolina Board of Examiners for Engineers & Surveyors.

UL - Underwriters Laboratory.

UTILITY – AQUA NORTH CAROLINA, INC.

WATER MAINS - water transmission mains, distribution mains, pipe, fittings, valves, hydrants, services, meters and miscellaneous related appurtenances.

WORK - the labor, materials, equipment, supplies, services and other items necessary for the execution, completion and fulfillment of the contract.

# Division 1

## Section 2

### Plan Review, Approval, Construction, and Acceptance of Water Improvements

#### 2.1 Plans, Specifications, and Models

- 2.1.1 General: All submitted plans should be a standard size sheet (24" x 36") with title block. Graphic scale(s) shall be provided on each sheet and all lettering shall be 1/8" or larger to permit photographic reproduction. All PLAN sheets and the title page of submitted SPECIFICATIONS, Engineer's Report & calculations must be signed, sealed and dated by the DEVELOPER'S ENGINEER in accordance with the rules and regulations of the NCBELS. All submitted plans, specifications, calculations, reports and any other associated documents will be submitted in hard copy and electronic copy. Electronic copies will be in a standard format of PDF and ACAD (DWG.). Any deviations in format must be preapproved by the UTILITY.
- 2.1.2 Master Plan: The entire water system shall be shown on a single Master Plan. For systems where the UTILITY is the owner and operator of both the water and wastewater systems, the entire water and wastewater systems will be shown on a single Master Plan. The Master Plan shall indicate the general locations of all mains, manholes, valves, hydrants, services and service laterals with respect to the proposed development improvements and the existing water and wastewater systems. Main sizes shall be indicated on the Master Plan.
- 2.1.3 Plan and Profile: All water mains shall be drawn in plan and profile. Any occurrence of phased construction should be clearly represented on the plan sheets upon submission to UTILITY for review.

Whenever possible, on-site water and wastewater systems shall be shown on the same PLAN sheet. As a minimum, the plan and profile drawings shall include the following information:

1. General information such as north arrow, names of designer and engineer, revision block with dates, graphic scale(s) and sheet number.
2. Profile with elevations at 10-foot interval, or more frequently if required by good design practice.
3. Development layout with horizontal and vertical controls.
4. All conflicts with other utility and drainage systems, including clearances.
5. Pipe data including size, lengths, class, and material.

6. Size, type, and locations of fittings, valves, hydrants, air release/vacuum relief valves and other related appurtenances.
  7. Limits of pipe deflection.
  8. Limits of special exterior coatings.
  9. Limits of special bedding requirements.
  10. Pipe restraint requirements.
  11. Details of connection to existing systems.
  12. Construction notes regarding cover, horizontal and vertical control, special construction requirements, and references to standard and special details.
- 2.1.4 Details: The PLANS shall include all applicable STANDARD DETAILS as shown in Division 4 of this MANUAL. Special details shall be prepared by the DEVELOPER'S ENGINEER for aerial and underwater crossings of rivers, streams, canals and ditches. Other special details shall be prepared by the DEVELOPER'S ENGINEER as required.
- 2.1.5 Scale: The master plan shall be prepared at a scale not to exceed 1" to 200'. Plan and profile sheets shall not exceed a scale of 1" to 50'. Special details shall be of sufficiently large scale to show pertinent construction information. On especially large systems, a larger scale can be used with the permission of UTILITY, or an overall plan of a greater scale can be used as long as smaller scale plans are also provided.
- 2.1.6 Hydraulic Modeling: A hydraulic model utilizing WaterCAD or WaterGEMS may be required for all new systems planning to provide irrigation, containing 2 wells or more or for any system connecting to a master system. On single well system, the Utility reserves the right to require modeling to verify pressure and flows. If the proposed system is to be connected to an existing system, the entire interconnected system shall be modeled. Contact UTILITY's engineer to determine if the model will be required. If a system provides fire flow, additional modeling may be requested.
- 2.1.6.1 If a hydraulic model already exists for the system being connected to, the DESIGNER, with the permission of the UTILITY, may provide a hydraulic model of the proposed system to be placed in the existing model. In this case, UTILITY shall provide pressure and flow data for the system being connected to.
- 2.1.7 General Notes: All drawings will have these notes somewhere in the set:
- Aqua North Carolina shall be notified 72 hours before construction is to begin.
  - Aqua North Carolina shall be notified 72 hours before any construction is buried.
  - Aqua North Carolina shall be notified 48 to 72 hours before any testing is conducted
- 2.1.8 Project Summary: A summary of the project will be included with the submittal. The submittal will include the following information, at a minimum. This summary can be combined with the Engineer's Report.

- Project name and location.
- Water system name and PWSID (if connecting to existing system).
- A brief description of the project.
- The number of proposed connections.
- All proposed wells/water sources with capacity and proposed storage (if applicable).

## 2.2 Subdivision Related Water Improvements

- 2.2.1 General: This section covers all water improvements that are dedicated to UTILITY.
- 2.2.2 Design and Plan Review: Design of water improvements associated with UTILITY approved projects shall be in compliance with the DESIGN STANDARDS in Division 2, and the SPECIFICATIONS outlined in Division 3 of this MANUAL. PLANS will be reviewed and approved by UTILITY as part of the project review and approval process. Any occurrence of phased construction should be clearly represented on the plan sheets upon submission to UTILITY for review.
- 2.2.3 Preconstruction Meeting: A preconstruction meeting will be required before work begins on any project. The meeting will consist of, at minimum, the DEVELOPER'S ENGINEER, the CONTRACTOR, and a representative of UTILITY. Other attendees can be required by UTILITY as needed, including any subcontractors and regulators. It shall be the CONTRACTOR's responsibility to contact any local and state regulators to see if their presence is required at the preconstruction meeting.
- 2.2.4 Construction Inspection: DEVELOPER's ENGINEER shall periodically inspect all construction subject to these STANDARDS and SPECIFICATIONS.

After all required improvements have been installed; the DEVELOPER'S ENGINEER shall submit certification to UTILITY that the improvements have been constructed substantially in accordance with approved PLANS and SPECIFICATIONS. A walkthrough of the improvements by the DEVELOPER'S ENGINEER and a representative of UTILITY to ensure compliance with the PLANS and SPECIFICATIONS will be required before closing. Non-compliance with approved PLANS or SPECIFICATIONS or evidence of faulty materials or workmanship shall be recorded by the DEVELOPER or DEVELOPER'S ENGINEER and if not corrected in an expeditious manner, all work on the project will be suspended and service withheld. **DEVELOPER'S ENGINEER is responsible for all inspections and certifications.**

## 2.3 Compliance with other Regulatory Requirements

- 2.3.1 It shall be the responsibility of the DEVELOPER to obtain and comply with all applicable Federal, State and Local regulatory requirements.
- 2.3.1.1 **SPECIFICALLY HIGHLIGHTED:**

**15A NCAC 18C .1537 DRINKING WATER TREATMENT CHEMICALS AND SYSTEM COMPONENTS**

- (a) The standards established by the American National Standards Institute/NSF International, codified as ANSI/NSF Standard 60 and ANSI/NSF Standard 61, are incorporated by reference including subsequent amendments and editions. ANSI/NSF Standard 60 applies to drinking water treatment chemicals. ANSI/NSF Standard 61 applies to drinking water system components. Copies may be obtained for public inspection as set forth in Rule .0503 of this Subchapter.
- (b) A water supply product used in a public water system shall meet the standards incorporated by reference in Paragraph (a) of this Rule. A product certified by an organization having a third-party certification program accredited by the American National Standards Institute to test and certify such products may be used in a public water system.
- (c) A supplier of water shall maintain a list of all water supply products used in a public water system for inspection by the Department. Prior to using a product not previously listed, a supplier of water shall either determine the product is certified as required by Paragraph (b) of this Rule or notify the Department of the type, name, and manufacturer of a product.
- (d) A supplier of water shall not introduce or permit the introduction of a water supply product into a public water system that does not meet the requirements of this Rule.

2.3.2 Acceptance of the PLANS by the UTILITY does not imply acceptance of the PLANS by any state or local authorities. It is the responsibility of the ENGINEER to submit the PLANS to all required agencies and to obtain any approvals necessary before construction is to begin.

**2.4 Guidelines for the Acceptance of New Water Mains from Contractors**

General: UTILITY as a purveyor of clean and high-quality water is responsible to prevent or minimize the exposure of its customers to any possible risk of chemical or microbiological contaminants that may result in illness to the community.

This document, which is in a flow chart format, is based on AWWA standard policies, practices, and procedures for accepting new water mains and is addressed to both internal operation personnel and outside contractors. The purpose of these guidelines is to provide a step by step procedure delineating the construction and final clearance of water main extensions.

It applies to all UTILITY facilities. All contract or operations employees are responsible and required to follow these procedures. Construction inspectors and supervisory employees will be responsible for ensuring compliance.

Incorporated Reference: ANSI/AWWA C651-92

**GUIDELINES FOR THE ACCEPTANCE OF NEW WATER MAINS FROM CONTRACTORS**

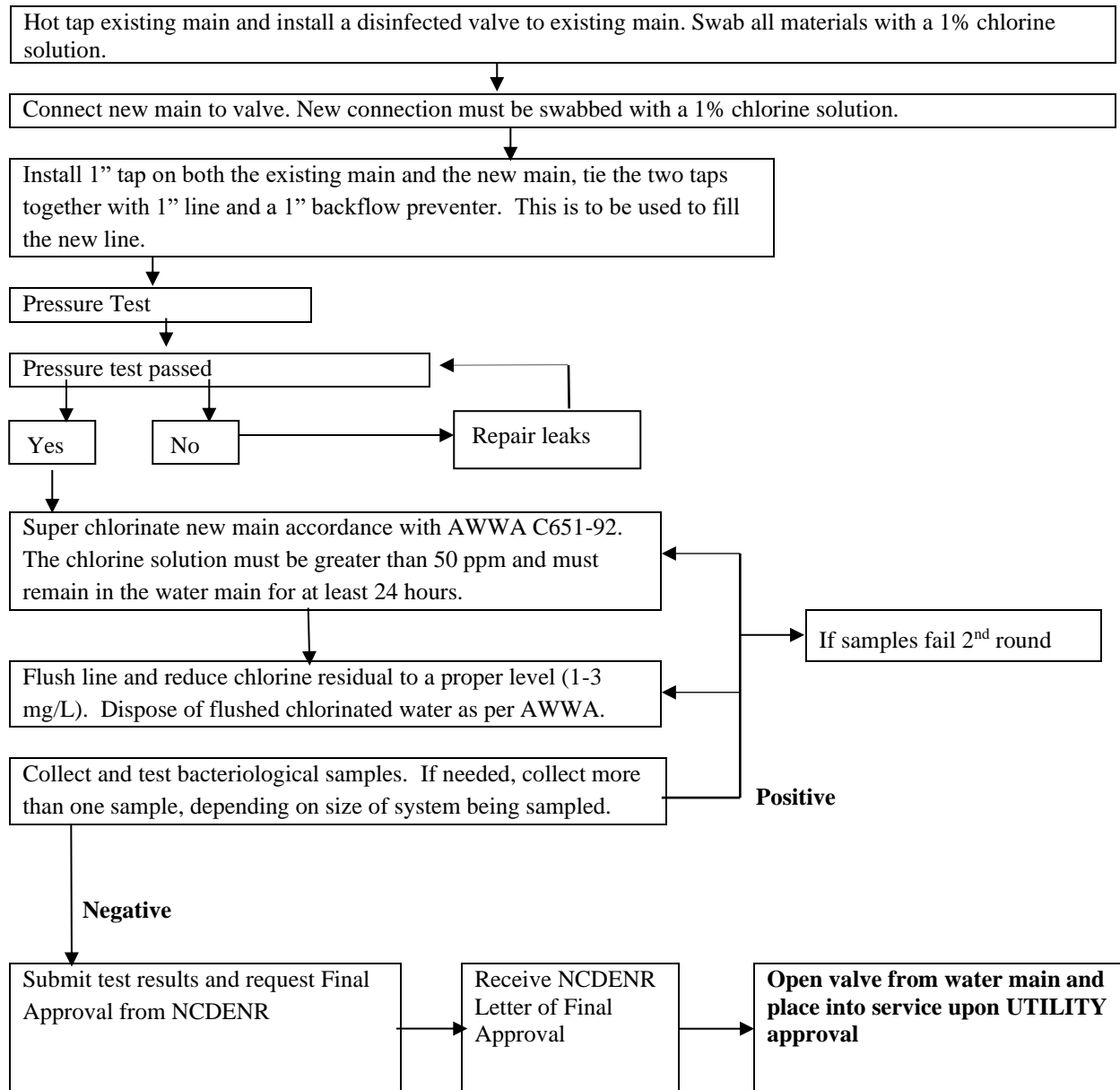

**2.5 Engineering Design Requirements**

- 2.5.1 NCDENR Application for Approval: NCDENR Application for Approval on Engineering Plans and Specifications shall name UTILITY as applicant.
- 2.5.2 Easements: PLANS shall clearly show and label all access and utility easements for any portion of the water system not within publicly dedicated rights of way, including any construction easements needed for the project.
- 2.5.3 NCDENR Submittal Documents: All applicable documents listed in the table below shall be provided by the project’s ENGINEER for UTILITY’s review prior to applying for NCDENR approval for Authorization to Construct.

Table 2.5.4

1	1 hard copy and 1 ‘.pdf’ set of Design Drawings.
2	1 copy and 1 PDF of the NCDENR Checklist for New Well Construction, sealed by the ENGINEER (see attached, this section).
3	1 hard copy and 1 ‘.pdf’ copy of Engineer’s Report, completed in the format approved by NCDENR pursuant to the RULES GOVERNING PUBLIC WATER SYSTEMS, sealed by the ENGINEER.
4	1 copy and 1 ‘pdf’ copy of the Project Summary.
5	1 copy and 1 ‘.pdf’ set of all water system design calculations, sealed by the ENGINEER.
6	1 copy and 1 ‘.pdf’ set of all well construction reports and testing reports for each well in the water system, if any.
7	1 copy and 1 ‘.pdf’ set of all project specification sheets and MSDS sheets
8	1 copy and 1 PDF of the NCDENR Application for Approval of Engineering Plans and Specifications for Water Supply Systems.
9	1 copy and 1 ‘.pdf’ set of the well lot survey for each well lot in the water system showing the well head location, the 100’ radius from the center of the well head and the 20’ access and utility easement to each well lot that does not front upon publicly dedicated rights of way, sealed by the SURVEYOR, if any.

## 2.6 Project Completion and Acceptance

### **UNDER NO CIRCUMSTANCES SHALL AQUA SUPPLY WATER UNLESS ALL OF THE FOLLOWING ITEMS ARE COMPLETED:**

**A – The Engineering Certificate is completed and submitted**

**B – All appropriate information is supplied so that an Applicant’s Certificate can be executed, is executed and submitted**

**C – Aqua receives appropriate Final Approval from all applicable regulatory agencies**

**D – All appropriate documents are supplied for the Closing Documents and the documents executed**

- 2.6.1 **Project Documentation:** All applicable documents shall be provided prior to project’s acceptance by UTILITY and prior to placing the water system in service. The format for these document submissions will be 1 hard copy and 1 PDF and 1 DWG (for drawings)
- 2.6.2 **Backflow Prevention Inspection Report and Testing:** CONTRACTOR is responsible for providing all reports and testing results per most current PWS rules and regulations.
- 2.6.3 **As-Built Inspection:** ENGINEER is responsible for scheduling field inspection/site visits by UTILITY prior to UTILITY’s acceptance of the project.
- 2.6.4 **ENGINEER’s Final Completion Package:** Documents listed in the table below shall be provided by the ENGINEER.

Table 2.6.5

1	Water system pressure and leakage test results and bacteriological analysis results.
2	ENGINEER’s Electronic Record Drawings for the project, which shall include the longitude and latitude of each valve, fire hydrant, meter, etc, in ‘.dwg’ format, AutoCAD Release 14 minimum, 2000, or 2000i
3	1 copy and 1 ‘.pdf’ set of ENGINEER’s signed and sealed Record Drawings for project



4	ENGINEER's Letter of Certification of Completion (signed, sealed, and dated) for the project. The original to be sent by the ENGINEER to NCDEQ.
---	---

2.6.6 Record Drawings: The DEVELOPER's ENGINEER shall submit a certified set of Record Drawings sealed by the Engineer prepared in conjunction with a North Carolina Licensed Professional Land Surveyor to ensure proper locations and coordinates of built and installed devices/facilities to UTILITY prior to acceptance of the project. The DEVELOPER's ENGINEER shall be responsible for recording information on the approved PLANS concurrently with construction progress. Record Drawings submitted to UTILITY, as part of the project acceptance shall comply with the following requirements:

- Record Drawings shall be legibly marked to record actual construction.
- Record Drawings shall show actual location of all underground and aboveground water and wastewater piping and related appurtenances (Plan and profile). For systems where UTILITY is the owner and operator of both the water and wastewater systems, the entire water and wastewater systems Record Drawings shall show all underground and aboveground water and sewer piping and related appurtenances. All changes to piping location including horizontal and vertical locations of utilities and appurtenances shall be clearly shown and referenced to permanent surface improvements. DRAWINGS shall also show actual installed pipe material, class, etc.
- Record Drawings shall clearly show all field changes of dimension and detail, including changes made by field order or by change order.
- Record Drawings shall clearly show all details not on original contract drawings but constructed in the field. All equipment and piping relocation shall be clearly shown.
- Location of all hydrants, meters, meter boxes, valves, and valve boxes shall be shown. A benchmark shall be shown on the plan referencing the state plane coordinate system.
- Record Drawing format shall be georeferenced .DWG file and .PDF.

Each sheet of the PLANS shall be signed, sealed and dated by the DEVELOPER'S ENGINEER as being "Record Drawings." Construction PLANS simply stamped "As-Built" or "Record Drawings" and lacking in the above requirements will not be accepted and will be returned to the DEVELOPER'S ENGINEER. The NCDENR "Applicant Certification" for Final Approval will not be released until correct "Record Drawings" have been submitted.

**AQUA CHECKLIST for NEW WELL CONSTRUCTION** Date: \_\_\_\_\_

Name of Public Water System: \_\_\_\_\_

Public Water System Identification number (PWSID) if known: \_\_\_\_\_

County: \_\_\_\_\_ Well name or number: \_\_\_\_\_

Engineer: \_\_\_\_\_

Well Driller's name: \_\_\_\_\_ Driller's Cert. number: \_\_\_\_\_

Casing: Length installed: \_\_\_\_\_ Type of Casing installed: \_\_\_\_\_  
(should be 50 ft. minimum below grade)

Casing should be grouted full length. Length of Casing Grouted: \_\_\_\_\_

Grouting Method Used:  
Pressure Method: \_\_\_\_\_ Pumping Method: \_\_\_\_\_ Other: \_\_\_\_\_

Well Site Deed(s) enclosed? ( Y / N ) Recorded Plat(s) enclosed? ( Y / N )

Drive shoe used on bottom of well casing? ( Y / N )

Signed well driller's log with driller's certification number ( Y / N )

Monitoring: Bacteriological Analysis ( Y / N ) VOC Results ( Y / N )

"New Well" Inorganic Results ( Y / N ) SOC Results ( Y / N )

Radiological (if required) ( Y / N ) Asbestos (if required) ( Y / N )

Nitrate/Nitrite (if not included in Inorganic Analysis) ( Y / N )

Signed 24-hour well yield and drawdown report enclosed? ( Y / N )

Engineer's well construction verification statement sealed and signed? ( Y / N )

Total dynamic head design calculations? ( Y / N )

Selected pump data and performance curves? ( Y / N )

3 sets of "Application for Approval"? ( Y / N )

Well site approval letter? ( Y / N )

By signing and sealing the below, the Engineer certifies that he/she or someone under his/her direct control was present for the drilling of the subject well. If not he/she certifies and provides a video investigation record/log of the new well submitted with these documents.

Engineer's Seal & Signature:

# **DIVISION 2**

## **DESIGN STANDARDS**

### **Design Standards**

## **Division 2**

### **Section 1**

#### **Aqua North Carolina Daily Flows**

##### **1.1 Design Demand**

- 1.1.1 DEVELOPER'S ENGINEER must confirm demands per RULES GOVERNING PUBLIC WATER SYSTEMS, latest edition. Demand calculations must be done according to these standards, Division 2, Section 5.3.2, or in accordance with the demand listed in the Developer's Agreement with UTILITY, whichever is more stringent.

## Division 2

### Section 2

#### Well Sites

##### 2.1 Location

2.1.0 **Stormwater credits and/or allowances:** For each individual well, whether multiple wells are located on the same lot or not, the developer shall place into Aqua's name/for Aqua's future use/ at Aqua's disposal adequate stormwater credits/permissions to construct up to a minimum net 7,850 square feet of impervious surface.

2.1.1 For approval, NCDENR and/or UTILITY rules require that **minimum** horizontal separation between public water supply wells and known potential sources of pollution be maintained as follows:

A. 100 feet from:

- Any sanitary sewage disposal system or sewer pipe;
- Any subsurface disposal area, disposal tank, leach field or filter backwash;
- Buildings, storage facilities, permanent structures, animal lots, or cultivated areas where chemicals are applied;
- Surface water;
- Chemical or petroleum fuel underground storage tanks with secondary containment;
- Any roads other than the well access road;
- Any other potential sources of pollution such as power transformers.

**Well sites down grade from individual septic tanks, near the 100' radius, are usually not accepted by NCDENR.**

B. 200 feet from:

- A subsurface sanitary sewage treatment and disposal system designed for 3000 gpd or more.

C. 300 feet from:

- A cemetery or burial ground

D. 500 feet from:

- A septage disposal site;
- Chemical or petroleum fuel underground storage tanks without secondary containment; including underground pipelines for transmission of petroleum products (cross-country).

- A boundary of a groundwater contamination area;
- A sanitary landfill or non-permitted non-hazardous solid waste disposal site.

E. 1000 feet from:

- A hazardous waste disposal site.

2.1.1.1 The well shall not be located in an area generally subject to flooding.

2.1.1.2 Note that NCDENR may require greater separation distances or impose other protective measures when necessary to protect the well from pollution (see RULES GOVERNING PUBLIC WATER SYSTEMS, section .0203, Public Well Water Supplies for more detail).

2.1.2 Well sites with drainage ditches or low spots capable of holding water within the 100' radius will not be accepted by the UTILITY.

2.1.3 Well site shall be approved by NCDEQ and a UTILITY Representative prior to drilling. Final approval of well site shall be dependent upon satisfactory completion of any NCDEQ and UTILITY provisos.

2.1.4 A certified survey of the well lot shall be provided prior to submittal for NCDEQ plan approval. The survey shall include topographic information. The coordinates of the well and county pin number shall be provided for each well drilled.

2.1.5 The well lot must be owned or controlled by the UTILITY. Developer shall provide Utility with an appropriate recorded deed of easement and/or general warranty deed which shall include well protective non-contamination provisions acceptable to UTILITY to ensure the required 100' radius is pollution-free. Said deed must be in the UTILITY's name and shall be recorded at the county's register of deed office prior to submittal for NCDENR plan approval and UTILITY accepting the well. A 20' utility and access easement shall also be granted to UTILITY.

## **Division 2**

### **Section 3**

#### **Design Criteria for Pumps & Motors**

##### **3.1 Submersible Motors**

- 3.1.1 Motors shall be manufactured by Franklin or Centri-pro and of the highest psi thrust bearing available. Any other manufacturer must be approved by UTILITY.
- 3.1.2 Three-phase power is required for sites. DEVELOPER and ENGINEER shall investigate the possibility of making three-phase power available before specifying a single-phase motor.
  - 3.1.2.1 On anything less than 10 hp, UTILITY may allow single-phase power.
- 3.1.3 Three phase motors 15 hp – 25 hp shall have a No. 8 pig tail or motor connector. The size pig tail or motor connector for larger motors shall be determined by the manufacturer.
- 3.1.4 All motors shall be new; remanufactured motors shall not be accepted.
- 3.1.5 The ENGINEER shall design the proper size drop wire in accordance with the latest Franklin or Century installation guide or the one provided with an equivalent motor used.
- 3.1.6 After motor is set in place, an insulation test shall be performed to ensure there are no shorts or grounds in the drop wire or motor. If grounds or shorts are found, the contractor will replace the drop wire and/or motor at no cost to the owner.
- 3.1.7 There shall be at least 20' of drop cable left out of well.
- 3.1.8 The appropriate 3-phase motor protection shall be provided as specified by UTILITY for the area served.
- 3.1.9

##### **3.2 Submersible Pumps**

- 3.2.1 Pumps shall be manufactured by Goulds or Grundfos (see Division 5, Section 1.2.2) unless otherwise designated by UTILITY.
- 3.2.2 The pump size and type shall be designed by the ENGINEER and approved by the UTILITY.
- 3.2.3 All pumps shall be set on galvanized pipe or approved equal, of the size approved by UTILITY, unless weight will not allow it. When galvanized drop pipe is not feasible Shur-Align PVC drop pipe shall be allowed upon engineering approval.

- 3.2.4 An inline spring check valve shall be installed at the pump. A pump set 300' or more shall have a second check valve of the same type, installed halfway up the drop pipe.
- 3.2.5 A ¼", polyethylene line of sufficient psi rating to overcome the static pressure shall be installed with pump. One end shall be just above the pump and the other end left out of well at least 30'. The tube shall be continuous with no couplings or cuts.
- 3.2.6 A galvanized "tee" shall hold the pump on the well seal.
- 3.2.7 A well seal of the proper size shall be used complete with an approved well vent of the steel type.
- 3.2.8 If the drop pipe is 2 1/2" or larger, the well seal shall be steel and made with a solid top.
- 3.2.9 The pump setting depth shall be based on fracture locations and stabilized pumping level and is to be reviewed by a Professional Geologist or ENGINEER.
- 3.2.10 Install a 1" (minimum) PVC pipe from the top of the well down to the level of the pump for determining water drawdown depth by acoustic or manual sounding.

### **3.3 Booster Pumps and Motors**

- 3.3.1 Booster pumps shall be manufactured by Goulds or Grundfos (see Division 5, Section 1.2.3) unless otherwise designated by UTILITY. The pump size and type shall be designed and/or approved by UTILITY. It shall be designed to pump the specified amount of gallons per minute at the specified pressure.
- 3.3.2 Motors for the pumps shall be of the manufacturer, horsepower, voltage, phase and hertz as specified or approved by the UTILITY.
- 3.3.3 Dual pumps with alternating, lead-lag and all necessary controls shall be installed.
- 3.3.4 Pumps shall be mounted on concrete pedestals at least 4" in height, with 4" over hang from each side of the pump, out of 3000 psi concrete. Lag bolts of the proper size shall be inserted in the concrete to mount the pump with. An 8" rubber matting shall be installed between the concrete and the pump base.
- 3.3.5 To prevent air-logging, each pump shall be equipped with an air release valve mounted on the highest point in the pump chamber. This air release will also have sanitary vent attached to it.
- 3.3.6 Either a flange or union shall be used at both the inlet and discharge piping where it enters the pump.
- 3.3.7 Each pump shall be equipped with a swing check valve of the specified type in the discharge side piping.
- 3.3.8 A gate or ball valve shall be installed in both the inlet and outlet piping. Gate valves shall be a rising OS&Y valve.
- 3.3.9 A tee with a ¼ inch ball valve with WOG rating of 600 psi shall be installed on both the intake and discharge side of the pump.



## Division 2

### Section 4

#### Water Treatment

##### 4.1 Chemical Equipment

- 4.1.1 A chemical pumping system complete with chemical pumps, solution tanks, tubing, injectors and shelf shall be provided at each treatment location.
- 4.1.2 Chemical pumps shall be 115 VAC of appropriate pressure and flow design requirements, or as specified by UTILITY, specified heads complete with foot valves and injectors or equivalent. Manufacturers' specific recommendations for components designed for the application of all chemicals shall be followed.
- 4.1.3 Solution tanks shall be specified by the UTILITY.
- 4.1.4 Three tees will be installed in valve bank after the check valve to accommodate chemical feed points with an 18" minimum separation between the phosphate and caustic feeds and 5 feet of separation between the phosphate and chlorine feeds. If specified, the phosphate feed point and caustic feed point should be placed immediately after the check valve and the chlorine feed point should be placed past the master meter for the best results.
- 4.1.5 To achieve optimum corrosion control, UTILITY may specify pH adjustment above the state minimum pH of 6.5. Required safety features for wells with caustic feeds include caustic relays wired into the starter and a flow switch installed along a straight section of valve bank at least 12" from an ell. A low flow - flow switch is required on wells producing less than 15 gpm and flow switch will be used on wells producing in excess of 15 gpm.
- 4.1.6 The chemical shelf shall be wall mounted, a minimum size of 2" x 12" x 4', and made of chemical-resistant material with two 10" x 12" shelf brackets and mounted 42" above finished floor to the top or as specified by UTILITY.
- 4.1.7 A Separate chemical feeder shall be used for each chemical applied.
- 4.1.8 Three separate duplex GFCI outlets with separate individual feed circuits/wiring from the electrical control panel shall be provided for the chemical feeders. For Clarification See standard details – specifically W-32A Typical Well House Wiring Diagram. Each duplex outlet will be a GFI/GFCI outlet.

##### 4.2 Filtration Requirements

- 4.2.1 All filtration/contaminant removal and/or waste disposal systems shall be designed by a licensed Professional Engineer, in cooperation with representatives of the UTILITY. These systems will be the sole discretion of the Utility and must be approved before

installation and implementation.

- 4.2.2 When the raw water quality from a new well exceeds the EPA, State Maximum Contaminant Levels (MCL's), or as otherwise discussed within these specifications, provision shall be made, in the well house and lot design and construction, for the addition of physical treatment and, potential waste disposal if approved by the UTILITY (see Division 2, Section 4.3).
- 4.2.3 All water filtration facilities will be equipped with radio controls/telemetry and programmed logic controls (PLC). Radio controls/telemetry shall be provided by UTILITY.
- 4.2.4 Water softening Treatment will only be allowed when there is a receiving sewer with a wastewater treatment plant approved to receive the Water Softening Treatment backwash.

When the receiving sewer is not owned or operated by the Utility (Aqua), a flow acceptance letter must be provided for the discharge

- 4.2.5 Waste Disposal Facilities: Recycle systems are required in accordance with all applicable laws including Federal, State and Local; but when not permissible: sewer, sub-surface, or stream discharge waste disposal methods are also acceptable, when permitted by the appropriate regulatory agencies. With the exception of onsite Recycle and Sludge disposal systems, all waste treatment facilities will be located outside of the well head protection radius and will be separated from the water treatment facilities by an air gap to prevent cross connection. Sub-surface disposal methods will require a repair area close enough to be dosed from the original waste treatment and disposal facilities.
  - 4.2.5.1 When applicable, a flow equalization/settling tank will be installed prior to any sand bed filters. Tank capacity will be sufficient to contain, at least, two complete waste cycle discharge volumes. No "septic" type tanks set above surrounding grade will be allowed.
- 4.2.6 An Operation and Maintenance Manual for the water treatment facilities will be provided to the UTILITY. This Manual will document the basic operation and maintenance issues and procedures for each equipment item and provide schedules for completion of routine tasks.
- 4.2.7 Start-up, Testing, and Operation: Project reports for treatment facilities will be provided to the UTILITY and must include schedules and performance standards for start-up, testing, and (initial) operation. Schedules should include the anticipated start-up date and proposed testing duration. Performance standards should include reference to applicable regulations and specific equipment capabilities.

### **4.3 Water Quality Parameters**

- 4.3.1 Iron (Fe): For any concentration below 0.3 mg/L, a sequestering agent shall be required. The polyphosphate required will be at Utility specification.
- 4.3.2 Manganese (Mn): For any concentration below 0.05 mg/L a sequestrant shall be required. The polyphosphate required will be at Utility specification. At concentrations

greater than 0.30 mg/L, Mn filtration or approved equivalent will be required.

- 4.3.3 If the Fe & Mn Combined Levels exceed 0.50 mg/L, or if the Mn levels are greater than .3 Mn filtration or approved equivalent for removal of iron and manganese will be required unless the Engineer submitting on behalf of the developer and/or Aqua can justify and explain how sequestering will be successful. At minimum, the explanation will include dosing and chemical feed calculations and show how the insoluble portion of Fe and Mn will be less than the current sMCL. . If the engineer of record provides an explanation it is required to receive approval from NCDEQ-PWS Plan Review Section. Failure to receive NCDEQ\_PWS approval will require filter installation. Under no circumstances will the Fe & Mn combined levels exceed 1.0 ppm without installation of iron and manganese filters.
- 4.3.4 Separate samples will be required for both soluble and insoluble Fe and Mn when concentrations are detected.
- 4.3.5 Sulfates: At or greater than 250 mg/l will require treatment and backwash permitting.
- 4.3.6 Total Dissolved Solids (TDS): At 500 mg/L or greater treatment shall be required.
- 4.3.7 Radionuclides levels are at 75% of the maximum contaminant levels, Filtration is required. An Alternative is to resampling at a schedule of four (4) hours, eight (8) hours, and twelve (12) hours at the permitted pumping rate. If these results are less than 75% of the maximum contaminant level, treatment will not be required.

## Division 2

### Section 5

#### Water Mains and Appurtenances

##### 5.1 General Considerations

- 5.1.1 Type of Water Mains: UTILITY will approve PLANS for water supply mains and extensions only when such mains are designed and constructed in accordance with the criteria set forth in this MANUAL.
- 5.1.2 Design Period: Water mains shall be designed for the estimated ultimate tributary population. Water systems shall be designed to satisfy the domestic water demand requirements for the area.
- 5.1.3 Location: Water mains shall be located in dedicated rights-of-way or utility easements. When installed in rights-of-way, water mains shall, in general, maintain a consistent alignment with respect to the centerline of the road. All water mains located outside of dedicated rights-of-way shall require a minimum 20-foot easement with a 5' on either side of the main clear of any other parallel utilities. Additional easement widths shall be provided when the pipe size or depth of cover so dictate. If a water main is located adjacent to a road right-of-way, a minimum 10-foot easement shall be provided. Additional easement widths shall be provided, if the pipe size or depth-of-cover dictates. Water mains shall not be placed under retention ponds, tennis courts, or other structures. In addition, water mains shall not be located along side or rear lot lines.
- 5.1.4 Construction Easements: All construction easements must be shown on the PLANS.

##### 5.2 Design Basis

- 5.2.1 Hydraulic Modeling: A hydraulic model utilizing WaterCAD or WaterGEMS will be required for all new systems containing 2 wells or more or for any system connecting to a master system. If the proposed system is to be connected to an existing system, the entire interconnected system shall be modeled.
  - 5.2.1.1 If a hydraulic model already exists for the system being connected to, the DESIGNER, with the permission of the UTILITY, may provide a hydraulic model of the proposed system to be placed in the existing model. In this case, UTILITY shall provide pressure and flow data for the system being connected to.
- 5.2.2 Average Daily Flow and Peak Flows: Average daily water flow shall be calculated by referencing the Water-Table of Daily Flows for Various Occupancies (Section 1). Maximum daily water flow shall be calculated as two times the average daily water flow and the peak hourly water flow shall be calculated as four times the average daily water flow.

- 5.2.3 Engineer's Report and Design Calculations: DEVELOPER'S ENGINEER shall submit signed, sealed and dated Engineer's Report and design calculations with the PLANS for all water distribution projects. Calculation shall show the water mains will have sufficient hydraulic capacity to transport peak hourly flows while meeting the requirements of Part 1, Division 2, Section 5.3.1 (below). Head losses through meters and backflow devices shall also be included in calculations. The Engineer's Report shall comply with the forms and guidelines given in the RULES GOVERNING PUBLIC WATER SYSTEM (Section .0307, Engineer's Report, Water System Management Plan and Other Plans). Any Engineer's Report that does not follow these guidelines may be rejected by the UTILITY.

### 5.3 Details of Design and Construction

- 5.3.1 Pressure: All water mains shall be designed in accordance with Section 5. The system shall be designed to maintain a minimum pressure of 40 psi at all points in the distribution system under all conditions of flow. Higher pressures may be required at commercial, industrial and high-density residential areas. The minimal normal working pressure in the distribution system shall be approximately 55 psi, but in no case less than 40 psi on the customer side of a meter. For pressures greater than 90 psi special provisions may be required. Design Friction Loss calculations for water mains shall be submitted with plans. AWWA Diurnal and a hydraulic model will be required to prove these requirements are met.
- 5.3.2 Design of Wells: Residential well capacity shall be based on a minimum of 1.0 gpm per residential connection, unless stated otherwise in the developer's agreement. Well capacity within the Bayleaf Master Water System (NC0392373) shall be based on a minimum of 1.5 gpm per residential connection. If PWS requirements or if a greater amount is given in the Developer's Agreement, the more stringent amount shall be used instead.
- 5.3.3 Design of Hydropneumatic Storage: When calculating the required effective and total volume, the Tank size shall be based on the North Carolina Public Drinking Water Regulations.
- 5.3.4 Diameter: Four-inch through 54-inch diameter water mains shall be allowed. As a minimum, four (4) inch-looped systems shall be required in low-density, residential projects. Where looping of mains is not practical, minimum six (6) inch mains shall be required, unless detailed calculations are submitted to substantiate the sufficiency of a smaller main (four (4) inch mains are allowed on the last 400' of a dead-end line). In commercial, industrial, and high-density residential areas, minimum eight (8) inch looped mains shall be required.
- 5.3.5 Dead Ends: In order to provide increased reliability of service and reduce head loss, dead ends shall be minimized by making appropriate tie-ins whenever practical, as determined by UTILITY.

Where dead end mains occur, they shall be provided with a hydrant or with an approved flushing hydrant or blow-off for flushing purposes. Flushing devices shall be sized to provide flows with a velocity of at least 3 feet per second in the water main being flushed. No flushing device shall be directly connected to any sewer or irrigation system. Calculations and a hydraulic model will be required to prove these requirements are met.

- 5.3.6 Valves: All Valves with be clock-wise closed and counter clock-wise open. Valves shall be provided on water mains so that sanitary hazards will be minimized during repairs. Valves shall be located at not more than 500-foot intervals in commercial, industrial and high-density residential areas and at not more than 1,000-foot intervals in all other areas. Valving shall be placed at all areas where water mains intersect in such a way as to ensure effective isolation of water lines for repair, maintenance or future extension.
- 5.3.7 Separation of Water Mains and Sewers: Refer to Division 3 of these SPECIFICATIONS for applicable requirements. No water pipe shall pass through or come in contact with any part of a sewer system. Extreme caution should be exercised when locating water mains at or near certain sites such as sewage treatment plants or industrial complexes. Individual septic tanks must be located and avoided.
- 5.3.8 Surface Water Crossings: UTILITY shall review and approve the PLANS on a case-by-case basis. All aboveground pipes shall be painted as specified in Division 3 for water mains.
- 5.3.9 Air Release Valves: Within 500 feet of the water entry point from a well to the distribution system and at all high points in water mains where air can accumulate, provisions shall be made to remove the air by means of automatic air release valves. At a minimum, air release valves should be placed where there is a change of pipe grade of 2 foot or more and spacing shall at least be one air release valve every 1,500 feet. Automatic air release valves shall not be used in situations where flooding of the manhole or chamber may occur. See details in STANDARD DETAILS.
- 5.3.10 Chamber Drainage: Chambers, pits or manholes containing valves, blow-offs, meters, or other such appurtenances to a distribution system shall not be connected directly to any storm drain or sanitary sewer, nor shall blow-offs or air relief valves be connected directly to any sewer.
- 5.3.11 Disinfection Following Repair or Replacement: Any part of UTILITY water system which has direct contact with finished water and has been out of service for repair, alteration, or replacement shall be disinfected as outlined in Division 3 of these SPECIFICATIONS.

#### **5.4 Water Services and Connections**

- 5.4.1 Water services and connections shall conform to the applicable provisions of Division 3 and the STANDARD DETAILS. Only ¾", 1", 1-1/2", 2", 4", 6", 8" and 12" services will be allowed. Where water services greater than 12" are required, dual services shall be provided. Water services and connections to existing UTILITY systems up to 2" will be made by UTILITY. Services and connections to new water systems and to existing systems larger than 2" shall be made by the CONTRACTOR.

A UTILITY representative must be on site during any connections to existing UTILITY systems.

CONTRACTOR shall not provide water service to new systems/line extensions other than for flushing and testing until the NCDEQ has issued a "Letter of Final Approval." To comply with regulations, the new connection shall not be placed into service until the

"Letter of Final Approval" from NCDEQ has been obtained.

- 5.4.2 For multiple connections to UTILITY existing water systems, the CONTRACTOR shall make the final connection upon UTILITY receipt of the NCDEQ "Letter of Final Approval" in accordance with the applicable AWWA in accordance with the applicable AWWA standard for disinfection of new water systems/ line extensions.

## 5.5 Water Metering

- 5.5.1 **General:** All water service connections shall be metered and be directly in front of the property. In general, gang meters are not accepted. The method of metering shall follow the guidelines listed below. However, the DEVELOPER'S ENGINEER must obtain approval before finalizing the design of the metering system.
- 5.5.2 Single Family Duplex and Multi-Family Subdivisions with Public Rights-of-Way: Each unit shall be individually metered. Single and double services shall be installed at property lines as indicated by the STANDARD DETAILS.
- 5.5.3 Single Family and Duplex Subdivisions with Private Streets: Individual meters may be permitted in accordance with Division 2, Section 5.5.2 if the private streets are designed to the applicable county standards and easements are dedicated over the entire private street common areas. In addition, sufficient area must be available outside of paved areas to locate water mains, services, and meters. If the above criteria cannot be met, the subdivision shall be metered pursuant to Division 2, Section 5.5.5.
- 5.5.4 Commercial, Industrial and Institutional Projects without Private Standby Water Lines: In general, each building shall be individually metered. Meter(s) shall be located in the public rights-of-way at the property line. If this is not practical, then the meter shall be located no closer than 5' from the front of the building.
- 5.5.5 Commercial, Industrial, Institutional, Multi-Family with Private Streets, Apartments and Condominium Projects with Private Standby Water Lines: In general, all such projects shall require installation of a RPZ check assembly on each dedicated standby water line. Where on-site standby water systems contain less than 75 feet of main, a dual system (separate domestic and standby water lines) may be considered. Dual systems shall require backflow prevention in accordance with UTILITY Backflow Prevention Policy, latest edition. Individual meters to each unit are required.
- 5.5.6 Shopping Centers: In general, shopping centers shall require installation of a RPZ check assembly on each dedicated standby water line. Individual meters to each unit are required.
- 5.5.7 Meter Installation: All meters greater than or equal to 2" in size shall be provided by and installed by the CONTRACTOR. Meters less than two inches in size will be installed by UTILITY after payment of applicable fees and charges. All meters less than two inches in size will be installed underground in an approved meter box. Meters two inch and larger shall be installed by the CONTRACTOR per UTILITY Comprehensive Meter Program and the STANDARD DETAILS. In general, meters larger than two inch shall be located in a meter easement located adjacent to the public right-of-way.
- 5.5.8 Meter Sizing: Size of all meters shall be approved by UTILITY. The DEVELOPER'S

ENGINEER shall provide sufficient information on estimated peak flows and low flows. The developer's ENGINEER shall include head losses through metering devices when designing the water system.

5.5.9 **Irrigation Meters:** During the installation of the water system for a new development, UTILITY will require one (1) 1-inch service line to be installed between the water main and each lot. In the event that the builder and/or homeowner chooses to install an in-ground irrigation system, the 1-inch line can be retrofitted to include a 1" x 3/4" tee to accommodate both a 3/4" domestic meter and 3/4" irrigation meter.

5.5.9.1 A Reduced Pressure Zone (RPZ) backflow prevention device shall be installed behind the irrigation meter. The RPZ shall be one of the following models. With UTILITY permission, another manufacturer with equal specifications and workmanship may be used.

- Cla-Val – RP2
- Conbraco - 400
- Febco – 825Y (D)
- Watts – Series 009QT
- Wilkins – WK 975XL-075

5.5.9.2 Before installing an in-ground irrigation system, reference the “AQUA NORTH CAROLINA RESIDENTIAL IRRIGATION METER INSTALLATION” guidelines.

## 5.6 Material, Installation and Testing

Applicable provisions of Division 3 and Division 4 shall apply.

### 5.6.1 Meter Boxes

Meter Boxes for up to 1-inch meters will be NDS D1200 Standard Water Meter Boxes and lids. Alternatives only allowed if approved by the Utility Engineer in writing. The meter Box Body at a minimum will be tapered and have a minimum wall thickness of 0.25 inch, have a double wall at the top cover seat area with a minimum thickness of 0.187 inch. The cover seat area shall have 30 structural support ribs on the underside of the seat, each with a minimum thickness of 3/16 inch. The bottom body shall have a 1.0-inch flange. The meter box cover shall have a minimum thickness of 0.25 inch. Boxes and lids shall be injection molded of structural foam polypropylene with a melt index of 10-12. Meter Box Covers (lid) will be a drop-in type lid with a 2.0-inch remote reading hole port and a cast iron reader flap. Meter box and lids shall be manufactured by the same manufacturer and designed to fit as a unit.

Placement of any meter within traffic loading areas or pavement areas is not preferred. If such an installation is proposed, it must be approved by the Utility Engineer in writing.

Meters and Meter Boxes/vaults larger than 1.0-inch will be approved on a case by case basis by the utility Engineer.



## **5.7 Location and Identification**

A means for locating and identifying all water mains and valves shall be provided in accordance with Division 3 and the STANDARD DETAILS.

## **5.8 Cross-Connection Control**

5.8.1 Location and Installation: In general, all backflow prevention assemblies shall be located directly following the water meter on developer/owner's property. If no meter is present (such as a building dedicated fire line) the backflow device shall be located that the right-of-way, edge of easement or edge of property line, and Aqua shall have no responsibility for the installation, operation or maintenance of the backflow device. Backflow prevention assemblies shall be installed aboveground to facilitate maintenance and testing and shall be operated with appropriate heat tracing for freeze protection. UTILITY's Cross Connection Control Policy shall be followed. It shall be the developer/owner's responsibility to purchase, install and maintain all backflow prevention assemblies. All cross-connection controls shall be tested and inspected by a North Carolina Department of Environmental Quality (NCDEQ) certified backflow prevention tester in accordance with state rules and regulations prior to acceptance by Aqua. Testable backflow devices shall be tested in accordance with State, Federal, and Local laws on a prescribed frequency but at a minimum of annually by a certified backflow prevention tester. Results from these tests shall be provided to Aqua NC. Any devices that are found to be defective shall be repaired immediately and follow-up test results provided to the UTILITY. Testing and maintenance of the backflow devices shall be the sole responsibility of the property owner. Failure to submit testing results and/or maintaining the devices in proper operational order could result in enforcement up to severance of service.

# **DIVISION 3**

## **CONSTRUCTION SPECIFICATIONS**

### **General Construction Requirements**

## Division 3

### Section 1

#### General

##### 1.1 Grades, Survey Lines, and Protection of Monuments

- 1.1.1 Grade: Benchmarks and base line controlling points shall be established prior to beginning work. Reference marks for lines and grades as the work progresses will be located so as to cause as little inconvenience to the prosecution of the work as possible. The CONTRACTOR shall place excavation and other materials as to cause no inconvenience in the use of the reference marks provided. CONTRACTOR shall remove any obstructions placed contrary to this provision.
- 1.1.2 Surveys: The CONTRACTOR shall furnish and maintain, at his own expense, stakes and other such materials, and give such assistance, including qualified helpers, for setting reference marks to the satisfaction of UTILITY and the ENGINEER. The CONTRACTOR shall check such reference marks by such means as he may deem necessary and, before using this, shall call UTILITY's attention to any inaccuracies. The CONTRACTOR shall, at his own expense, establish all working or construction lines and grades as required from the reference marks, and shall be solely responsible for the accuracy thereof. The CONTRACTOR shall, however, be subject to the check and review of UTILITY.
- 1.1.3 Monument Preservation: Property comers and survey monuments shall be preserved using care not to disturb or destroy them. If a property comer or survey monument is disturbed or destroyed during construction, whether by accident, careless work, or required to be disturbed or destroyed by the construction work, said property comer or survey monument shall be restored by a land surveyor registered in the State of North Carolina. All costs for this work shall be paid for by the CONTRACTOR.

##### 1.2 Utility Coordination

- 1.2.1 Location of Utilities: Prior to proceeding with trench excavation the CONTRACTOR shall contact all utility companies in the area to aid in locating their underground services. It shall be the contractor's responsibility to contact utility companies at least three (3) normal working days before starting construction. The CONTRACTOR shall proceed with caution in the excavation and preparation of the trench so that the exact location of underground utilities may be determined.

The CONTRACTOR shall take all reasonable precautions against damage to existing utilities. However, in the event of a break in an existing water main, gas main, sewer or underground cable, the CONTRACTOR shall immediately notify the responsible official of the organization operating the interrupted utility. The CONTRACTOR shall lend all possible assistance in restoring services and shall assume all cost, charges, or claims

connected with the interruption and repair of such services.

- 1.2.2 Deviations Occasioned by Structures or Utilities: Wherever obstructions are encountered during the progress of the WORK and interfere to such an extent that an alteration in the PLANS is required, the ENGINEER shall have the authority to order a deviation from the line and grade and the UTILITY shall have final approval authority. If a change in line or grade of a gravity sewer is necessary, UTILITY will require the addition of any manholes needed to maintain the integrity of the sewer system.
- 1.2.3 Test Pits: Test pits for the purpose of locating underground pipeline, utilities, or structures in advance of the construction shall be excavated and backfilled by the CONTRACTOR. Test pits shall be backfilled immediately after their purpose has been satisfied and maintained in a manner satisfactory to the applicable county and UTILITY. The costs for such test pits shall be borne by the CONTRACTOR.
- 1.2.4 Protection of Existing Facilities: Temporary support, adequate protection and maintenance of all underground and surface utility structures including sewers, manholes, hydrants, valves, valve covers, and miscellaneous other utility structures encountered in the progress of the WORK shall be furnished by the CONTRACTOR at his expense. Any such structures which may have been disturbed shall be restored upon completion of the WORK.

### **1.3 Construction in Easements and Rights-of-Way**

- 1.3.1 Construction in Easements: In easements across private property, the CONTRACTOR shall confine all operations within the easement area and shall be responsible and liable for all damage outside of the easement area. Trees, fences, shrubbery or other type of surface improvements located in easements will require protection during construction. Precautions shall be taken by adequate sheeting or other approved method to prevent any cave-in or subsidence beyond the easement limits or damage to improvements within the easement. In general, the easement area is intended to provide reasonable access and working area for efficient operation by the CONTRACTOR. Where easement space for efficient operation is not provided, the CONTRACTOR shall be responsible for organizing his operations to perform within the restrictions shown on the PLANS.
- 1.3.2 Construction in NCDOT Right-of-Way: The CONTRACTOR shall conform to all requirements of the NCDOT where construction work is in a right-of-way under the jurisdiction of the State of North Carolina. CONTRACTOR is required to have a copy of the encroachment agreement on the site at all times.
- 1.3.3 Construction in County Right-of-Way: WORK shall be governed by the applicable county right-of-way utilization regulations.

### **1.4 Suspension of Work due to Weather**

During inclement weather, all WORK which might be damaged or rendered inferior by such weather conditions shall be suspended. During suspension of the WORK from any cause, the WORK shall be suitably covered and protected so as to preserve it from injury by the weather or otherwise.

### **1.5 Cooperation with other Contractors and Forces**

During construction progress, it may be necessary for persons employed by UTILITY to work in or about the site. UTILITY reserves the right to access to the construction site at such times as UTILITY deems proper. The CONTRACTOR shall not impede or interfere with and shall cooperate with UTILITY for proper execution of the WORK.

#### **1.6 Subsurface Exploration**

The CONTRACTOR shall conduct subsurface explorations as necessary to perform the WORK.

#### **1.7 Salvage**

Any existing UTILITY owned equipment or material including but not limited to pumps, motors, control panels, valves, pipes, fittings, couplings, etc. which are removed or replaced as a result of construction shall be designated as salvage by UTILITY. If considered as salvage, the material shall be carefully excavated if necessary and delivered to UTILITY at a location designated by UTILITY.

#### **1.8 Shop Drawings and Samples**

The CONTRACTOR shall submit one (1) hard copy and one electronic copy (PDF) of the shop drawings, signed by the DEVELOPER'S ENGINEER, to UTILITY for approval. The data shown on the shop drawings shall be complete with respect to dimensions, design criteria, materials of construction and the like to enable review of the information as required.

The CONTRACTOR shall, if requested by UTILITY, furnish certificates, affidavits of compliance, test reports, or samples for check analysis for any of the materials specified in this MANUAL.

#### **1.9 Refurbished Materials**

All materials for construction shall be new materials. Any refurbished materials shall be allowed at the judgment and upon approval of the UTILITY Construction Coordinator.

## Division 3

### Section 2

#### Well Site Preparation

##### 2.1 General

This Section covers the clearing, grubbing, stripping, grading, and any other work needed to prepare the construction site. The CONTRACTOR shall clear and grub all of the areas within the limits of construction as shown on the PLANS and approved by the COUNTY prior to the beginning of any WORK. All site work shall conform to the applicable site clearing, landscaping and tree ordinances of the applicable COUNTY or local governing jurisdiction.

##### 2.2 Clearing and Grubbing

2.2.1 Clearing: The surface of the ground for the area to be cleared and grubbed shall be completely cleared of all timber, brush, stumps, roots, grass, weeds, rubbish and all other objectionable obstructions resting on or protruding through the surface of the ground. Protect trees, shrubs, vegetative growth and fencing which are not called out for removal. Clearing operations shall be conducted so as to prevent damage to existing structures, installations and to those under construction, so as to provide for the safety of employees and others.

2.2.2 Grubbing: Grubbing shall consist of the complete removal of all stumps, roots larger than 1-1/2 inches in diameter, matted roots, brush, timber, logs and any other organic or metallic debris not suitable for foundation purposes, resting on, under or protruding through the surface of the ground. All depressions excavated below the original ground surface for or by the removal of such objects shall be refilled with suitable materials and compacted to a density conforming to the surrounding ground surface.

2.2.3 Stripping: In areas so designated, top soil shall be stripped and stockpiled. Topsoil stockpiled shall be protected and seeded to protect from erosion until it is placed as specified. Any topsoil remaining after all WORK is in place shall be disposed of by the CONTRACTOR unless directed otherwise by UTILITY.

##### 2.3 Grading

###### 2.3.1 Access & Site Grading

- A. Well site shall be sufficiently graded to allow access and set up of drilling equipment.
- B. Additional grading may be required for well testing equipment.

###### 2.3.2 Finished Grading

- A. Well site shall be graded so that finished ground level of the well is at least 12" above the surrounding area within a 30' radius to ensure that surface water drains away from the well in all directions. A minimum of 20' of this radius shall be level within 3" for the construction of the house. No water shall be allowed to collect at any point within the 100' radius. The entire site shall be graded to provide for positive drainage away from the wellhead and so any storm water that enters the 100' radius shall drain to points outside the radius.
- B. Only clean fill dirt shall be used to fill well sites. Fill dirt shall be compressed and compacted every 18" of fill. If UTILITY's Representative is not satisfied with the compaction and the compaction is not sufficient to support the facility and storage tank, compaction tests may be required to be done by a qualified agency. If it is found that the site is not compacted properly, the CONTRACTOR shall pay to correct the problem.
- C. No potential sources of contamination including fertilizers, chemical or petroleum substances shall be placed within the 100' radius of the well head.
- D. All pushed up shrubs, trees, etc, shall be removed from well site during excavation and prior to the finish grading. No burying of shrubs & trees shall be acceptable. In addition, no dumping shall be allowed on to the well site.
- E. Prior to acceptance by Utility, the Owner shall be responsible for removal of all debris or non-permitted substances on well lot.
- F. Final grading of the well site shall be smooth and ready for grassing and/or graveling.

## 2.4 Grassing

2.4.1 Well site shall be grassed.

2.4.2 Grassing:

2.4.2.1 Grass seed shall be applied evenly. Hydroseeding is permitted so long as no unapproved materials are used (see 2.3.2.2, below). Refer to the materials list for approved grass types.

2.4.2.2 Straw shall be applied over grass seed. Jute or coconut matting will be required for steeper slopes as needed and in areas where excessive erosion is noted. No fertilizers, chemicals or petroleum products shall be placed on the well site.

2.4.2.3 The contractor shall ensure a good stand of grass

2.4.3

## 2.5 Roads

**PLEASE NOTE: References to access roads, turn arounds, widths of roads and road construction with these specifications and associated documents are Aqua NC's minimum standard. Other Agencies such as**

**the Fire Service, EMS, and Sherriff's Departments may have more stringent/conservative requirements. An example would be the North Carolina Fire Code – Appendix D “Fire Apparatus Access Roads”. It is the responsibility of the Engineer and Construction Contractor to coordinate design/construction of these access roads/turn arounds with the local Fire Marshal. Design and Construction will meet all requirements – Aqua NC and other agencies.**

- 2.5.1 There shall be an all-weather access road of at least 10' in width constructed within the recorded 20' easement to each well site with a 15'x25' turn around area of at the well adequate to accommodate complete turnaround of service vehicles, unless otherwise specified by local ordinances.
- 2.5.2 Access roads shall be graded with a minimum of 6" center crown in the road. If determined by the Inspector, side ditches to allow water to run off will also be required. At UTILITY Representative's discretion, rip rap may also be required on steep inclines.
  - 2.5.2.1 All drainage ditched shall be lined with excelsior rolled erosion product to protect from erosion.
- 2.5.3 Road and side ditches shall be so constructed as to not direct or allow water runoff to drain toward the wellhead.
- 2.5.4 The finished access road shall be adequately compacted and covered with at least 6" of crush and run gravel and extend from the street to the doors of the facility (including turn around area) and the slab surrounding the wellhead.
- 2.5.5 Culvert pipe shall be placed in all low areas of access road and sized to handle flow of 50-year flood.
- 2.5.6 Road shall be designed and constructed to allow access of large equipment and allow re-drilling of the well, if necessary.
- 2.5.7 Road shall not exceed 12% grade without written consent of UTILITY.
- 2.5.8 A controlled access acceptable to the UTILITY shall be provided at each well site and shall consist of a post and cable properly marked, a gate, or mallard. UTILITY's Representative shall determine which method shall be acceptable.
- 2.5.9 Graveling:
  - 2.5.9.1 Well drive and turn around shall be graveled. The gravel shall be placed so as not to direct water towards the well and also not to block the access to the facility.
  - 2.5.9.2 Gravel shall be 3/4" or smaller crush and run and shall be applied at least 6" thick. Alternatives may be considered (such as #57 or #67 stone or asphalt paving if approved by UTILITY) based on what is deemed suitable to the



neighborhood and acceptable to the UTILITY.

- 2.5.9.3 Graveled areas shall include geotextile between gravel layer and compacted earth surface. Geotextile shall be designed for drainage and separation. Geotextile shall have a minimum grab tensile strength of 120 lbs or greater.

## Division 3

### Section 3

#### Wells

##### 3.1 Grading

###### 3.1.1 Access & Site Grading

3.1.1.1 Well site shall be sufficiently graded to allow access and set up of drilling equipment.

3.1.1.2 Additional grading may be required for well testing equipment.

##### 3.2 General

3.2.1 An on-site meeting with a UTILITY Representative shall be held prior to drilling a well. UTILITY must be notified a 1 week in advance prior to beginning drilling, setting the casing and beginning grouting.

3.2.2 Well shall be drilled at the specified well stake put in the ground by the surveyor, as approved by NCDENR, and in accordance with these specifications (see Section 1).

3.2.2.1 If the well is not drilled in staked location designated by the surveyor or does not have a minimum 100' radius approved by the State, the UTILITY shall not accept the well.

3.2.3 The well drilling contractor and/or DEVELOPER shall obtain any and all required permits needed to drill a well. Penalties assessed for not obtaining the required permits shall be the sole responsibility of the CONTRACTOR and/or DEVELOPER. UTILITY shall not be liable if the required permits are not obtained.

###### 3.2.4 Well Diameter

3.2.4.1 Rock Wells: All rock wells shall be drilled with a minimum 8" well casing . UTILITY requires that the well hole from the bottom of the casing be drilled with a minimum 8" diameter for the full length of the well unless otherwise specified by the UTILITY. Exceptions must be approved by the Utility in writing.

3.2.4.2 Sand Wells: All sand wells shall be drilled with a minimum 8" well casing unless otherwise specified by the UTILITY.

3.2.5 Only potable water shall be used in the process of well drilling. Tanks and vessels carrying water for drilling purposes must be chlorinated to a minimum 50 parts per

million each time they are filled. All chlorine products must be free of sun inhibitors or sun stabilizers. Water from sources, such as unapproved wells, lakes, ponds, rivers, streams, etc, shall not be used.

- 3.2.6 All other drilling fluids and additives used shall comply with recognized industry standards and practices and be applied and used as prescribed by the manufacturer. Toxic and/or unapproved substances shall not be added to drilling fluid.
- 3.2.7 Wells shall be drilled straight and plumb the entire depth of the well. Crooked wells will not be accepted. If Aqua determines the wells is not plumb, i.e unable to install a temporary pump or permanent pump, Aqua will require a new well to be drilled at others expense
  - 3.2.7.1 Rock Wells: The well driller shall attempt to drill to a depth at least fifty (50) feet beyond the last water-bearing fracture.
  - 3.2.7.2 Sand Wells: Casing shall extend at least one (1) foot into the top of the water-bearing formation and in no case be less than 55 feet below ground level.
- 3.2.8 The well shall be constructed in accordance with all State and County regulations, AWWA standards and UTILITY specifications.
- 3.2.9 The well shall be thoroughly cleaned of all drill cuttings prior to the removal of the drilling equipment.
- 3.2.10 At the completion of drilling, the well drilling contractor shall chlorinate the well with granular and tablet chlorine such as HTH or equivalent to a tested level of 100 ppm for 24-hours in accordance with AWWA rule C654 and section .1002 of *The Rules Governing Public Water Supply Systems* (NCAC Title 15A, Subchapter 18C, Section 1002). All chlorine products must be free of sun inhibitors or sun stabilizers.
- 3.2.11 A signed and complete copy of the State and/or County required well drilling record/log shall be submitted to UTILITY showing the name of the Subdivision, well number, coordinates of well, well drilling company, date drilled, depth of well, depth of casing, drive shoe, depth of the grouting and placement method used, static water level, depth and yield at each water zone (including those zones cut off by the installation of the casing), total yield, etc. Well records without the above data will not be accepted.

### 3.3 Well Casing

- 3.3.1 Drive shoe (Rock Wells only) - A drive shoe must be installed on the end of casing. The drive shoe shall be made of forged, high carbon, tempered seamless steel and shall have a beveled, hardened cutting edge. This shoe shall be firmly driven into the rock at least 5' into competent bedrock to make a seal with 10' being preferred. **This should be documented on the signed well construction report.**
- 3.3.2 Casing material - New casing which bears mill markings and which conforms to standard specifications – carbon steel or approved equivalent for water well pipe shall be used. Casing shall be 8" inch heavy weight (0.322" wall thickness), carbon steel or ASTM F480 galvanized or approved equivalent for water well pipe unless otherwise specified. Thermoplastic casing will not be accepted on rock wells.

- 3.3.3 Casing length (Rock Wells only) - Where firm bedrock is encountered shallower than 55 feet, a minimum casing length of 55 feet below ground level will be required. Unless otherwise specified by the on-site Utility Representative, the well must be drilled a minimum of 5' into competent bedrock where the drive shoe and casing must be secured.
- 3.3.4 Method of joining - Casing lengths shall be joined in alignment and water tight by a method appropriate to the material used so that the resulting joint shall have the same structural integrity and protection as the casing itself. Threaded and coupled joints shall be API or equivalent and made up tight. Welding is acceptable.
- 3.3.5 Sanitary protection of the well - The well site shall be protected at all times during the drilling. The casing shall be sealed with a suitable flanged, threaded, welded cap, or compression seal upon completion. The top of the outside casing shall extend at least 12" above concrete finished floor level/elevation.
- 3.3.6 There shall be no openings in the casing wall below its top except for water level measurement access ports, vents, or grout nipples. Such openings shall be sealed water tight prior to leaving the well site.
- 3.3.7 An identification plate shall be attached to each public well immediately after drilling is completed. The well drilling contractor shall furnish a completed well identification plate as outlined below prior to leaving the job site. The well will not be accepted without this tag.
- 3.3.7.1 The identification plate shall be constructed of a durable, weatherproof, rustproof metal or equivalent material.
- 3.3.7.2 The identification plate shall be securely attached to the well casing where it is readily visible.
- 3.3.7.3 The identification plate shall be stamped with permanent markings to show the following information:
- Drilling contractor and registration number.
  - Date well completed.
  - Total depth of well.
  - Casing: Depth (feet), Inside Diameter (inches).
  - Yield or specific capacity expressed in gallons per minute (gpm), or gallons per minute per foot of draw down (gpm/ft.dd).
  - Static water level and date measured.
  - Gravel and screen size (if applicable).

### **3.4 Well Grouting**

- 3.4.1 Grouting materials - For all community wells, composition of grout must meet State requirements.
- 3.4.2 The entire length of the well casing shall be grouted completely before the driller leaves

the site, i.e., in one pour.

- 3.4.3 The UTILITY may specify pressure grouting a well from the inside of the end of the casing out into the annular space; however tremie grouting is the preferred method. Or the UTILITY may specify grouting to the end of the casing within the annular space using two tremie pipes to ensure good distribution around the casing.
  - 3.4.3.1 (Rock Wells only) Contractor shall not pour concrete. Well shall be grouted using the following method: grouting to the end of the casing within the annular space using tremie pipes to ensure good distribution around the casing, or pressure grouting.
- 3.4.4 Below are the specifications for using these types of grouting methods.
  - 3.4.4.1 Grout material shall be placed by tremie pumped or forced injection after water or other drilling fluid has been circulated in the annular space sufficiently to clear all obstructions including rock chips in Type I wells.
  - 3.4.4.2 In accordance with State regulations, there must be a minimum annular space equal to either one-third of the outside diameter of the casing or at a minimum two inches.
  - 3.4.4.3 When emplacing the grouting material, the tremie pipe shall be lowered to the bottom of the zone to be grouted and raised slowly as the grout material is introduced.
  - 3.4.4.4 The tremie pipe shall be kept full continuously from start to finish of the grouting procedure, with the discharge end of the tremie pipe being continuously submerged in the grout until the zone to be grouted is completely filled.
  - 3.4.4.5 The grout must be allowed to properly cure at least 24 hours before construction may be resumed.
- 3.4.7 (Rock Wells only) For sanitary protection, the well should be grouted from the bottom of the casing secured in firm bedrock. Special care must be taken to set casing and grout into Piedmont crystalline rock and not just too overlying isolated boulders or iron hardpan. Additional length of grout may be necessary in some cases to support the weight of the casing.

### **3.5 Well Screens (Sand Wells only)**

- 3.5.1 The well shall be equipped with a screen that will adequately prevent the entrance of formation material into the well after the well has been developed and completed by the well contractor.
- 3.5.2 The well screen will be of a design to permit the optimum development of the aquifer with minimum head loss consistent with the intended use of the well. The openings shall be designed to prevent clogging and shall be free of rough edges, irregularities or other defects that may accelerate or contribute to corrosion or clogging. How this design is determined shall be included with the Engineer's submittal for approval. ( i.e. were samples sent to the screen manufacturer to determine optimum screen size, etc.)

3.5.3 Multi-screen wells shall not connect aquifers or zones which have differences in water quality with would result in contamination of any aquifer or zone.

3.5.4 Under no circumstances will a well screen be set less than 55 feet below land surface.

### **3.6 Gravel and Sand Packed Wells (Sand Wells only)**

3.6.1 In constructing a gravel or sand packed well:

3.6.1.1 The packing material shall be composed of quartz, granite, or similar rock material and shall be clean, of uniform size, water-washed and free from clay, silt, or other deleterious material.

3.6.1.2 The size of the packing material shall be determined from a grain size and of the formation material and shall be of a size sufficient to prohibit entrance of formation material into the well in concentrations above five (5) milliliters per liter of settleable solids and ten NTU's of turbidity as suspended solids as permitted under N.C.2C Rules.

3.6.1.3 The packing material shall be placed in the annular space around the screens casing by a fluid circulation method, preferable through a conductor pipe to insure accurate placement and avoid bridging.

3.6.1.4 The packing material shall be adequately disinfected.

3.6.1.5 Centering guides must be installed within five (5) feet of the top packing material to ensure even distribution of the packing material in the borehole.

3.6.2 The packing material shall not connect aquifers or zones which have differences in water quality that would result in deterioration of the water quality in any aquifer or zone.

### **3.7 Well Development**

3.7.1 All water supply wells shall be properly developed by the well driller;

3.7.2 Development shall include removal of formation materials, mud, drilling fluids and additives such that the water contains no more than:

3.7.2.1 five (5) milliliters per liter of settleable solids; and

3.7.2.2 ten (10) NTUs of turbidity as suspended solids.

### **3.8 Testing**

3.8.1 No well shall be accepted when the drawdown test results are less than 15 gallons per minute unless accepted and approved by the Utility in Writing. .

3.8.2 A UTILITY Representative shall be present at start and completion of the drawdown. UTILITY must be provided 1 week notice prior to start of drawdown testing.

- 3.8.3 Test pump shall be set at the depth specified by UTILITY and shall be of sufficient size to determine the true well yield.
- 3.8.4 Perform a step test at a maximum of one hour, minimum of thirty minutes, or between as the production stabilizes (Step test with a minimum steps of 30 to 60 minutes). The steps should be performed in the following order: 50% production, 75% production, 100% production, and 125% production. The water level should be checked every one (1) minute and will be considered stable after ten (10) stable representative reads. If the production stabilizes quickly at 125% a similar test should be performed at 150% production.

Water level measurements shall be collected by hand or by acoustic monitoring.

- 3.8.5 A 24-hour test with a two-hour recovery shall be run without interruption. If the test is interrupted for any reason, it shall be the contractor's responsibility to re-run a complete test at no extra charge to the owner. Wells that have not been placed in service within two years of the date the well was drilled will require a current 24-hour well drawdown test to be completed.
- 3.8.6 Wells in close proximity to other community wells and/or private wells will be required to be tested simultaneously in accordance with State and Local Regulations.
- 3.8.7 This test shall be run in accordance to UTILITY's specifications, which are as follows:

3.8.7.1 GPM and Pumping Level –

- Check every 5 minutes for 1st hour
- Check every 10 minutes for 2nd hour
- Check every 15 minutes for 3rd hour
- Check every 30 minutes for 4th hour
- Check every hour for remainder of test

3.8.7.2 Field Water Quality Parameters - Field water quality parameters (iron, manganese, hardness and pH) shall be tested as follows:

- 1st hour then,
  - Every 4 hours thereafter, then,
  - At the end of the test
  - Field samples should be pulled more often if parameters are not within limits.
- \*The drawdown/capacity test will NOT be accepted unless the field water quality parameters are collected and the results recorded on the 24 hour drawdown report**

3.8.7.3 New well analysis samples shall be collected between the 10<sup>th</sup> to 12<sup>th</sup> hour of the 24 hour draw-down test.

3.8.7.4 After the 24-hour test is run, shut off the pump and start the recovery test as stated below.

3.8.7.5 Recovery Static Level -

- Check every 1 minute for 1st 30 minutes

- Check every 10 minutes for 2nd 30 minutes
  - Check every 15 minutes for 3rd 30 minutes
  - Check every 30 minutes for 4th 30 minutes
- 3.8.8 Water sample results must meet all regulatory and/or UTILITY water quality standards. The following contaminants will be sampled from every new well: bacteriological, inorganic chemical, including gross alpha and beta particles, uranium, radium 226 and 228, volatile organic chemicals, synthetic organic chemicals, Asbestos (as applicable), and any other regulated or unregulated contaminants as deemed necessary by the UTILITY. At least one copy of these analyses shall be submitted to UTILITY.
- 3.8.9 After the test pump is removed, the contractor shall rechlorinate the well to at least 100 ppm for 24-hours as required by AWWA rule C654 and recap it.
- 3.8.10 At least one signed hard copy and one electronic (PDF) copy of the well drawdown test shall be submitted to UTILITY.
- 3.8.11 Test log shall include gallons per minute, static water level, pumping water level, above ground head, time, turbidity of water, depth of any noted cascading of water, and all field parameter testing results.
- 3.8.12 A videotape shall be made of the well and a copy presented to the UTILITY. Should the video indicate that well construction deficiencies exist, the owner of the well shall be responsible for all necessary construction modifications. Any additional drawdown tests or any water analyses required due to construction modifications will be at the well owner's expense.
- 3.8.13 The Available Yield of the well shall be considered to be 90 percent of the 24-hour draw down stabilized pumping rate. If the specific capacity of the well is greater than 1, then 100% of the pumping rate may be used. The 1 gallon per minute per connection will be based on the Available Yield of 90%. Unused Capacity available shall not exceed the 90% threshold and is subject to a new pump test at the time of the new request and at each request thereafter.
- 3.8.14 Resampling: When at the discretion of the UTILITY, sufficient cause exists to resample water quality parameters, then a modified draw down test shall be run for, at least 3 volumes of the well or for the length of time as determined by the UTILITY, at the stabilized draw down pumping rate. The water quality samples for laboratory analyses shall be drawn at the end of the modified draw down test. If field parameter testing during the original draw down test indicated significant changes in water quality during the 24-hour test, then the resampling draw down test will run through the time of the changing concentrations, but no less than 3 hours. During the modified draw down testing, all field parameters shall be sampled at the above frequencies.
- 3.8.15 When well modifications are made to significantly alter the hydrologic or water quality conditions (i.e. a packer, liner, or concrete fill), or the well has not been activated within 2 years, then a complete draw down test shall be conducted on the modified well. Water samples to be pulled at the end of the test to determine the new sample results.

### **3.9 Well Abandonment**



- 3.9.1 In the event that a well is not accepted by the Utility, it shall be abandoned in accordance with the North Carolina Administrative Code, Subchapter 2c, Section .0113 and Section .0114 and in accordance with County rules and regulations. A representative of the UTILITY shall be notified of the well abandonment 24-hours prior to completing the abandonment for Inspection purposes.
- 3.9.2 An official Well Abandonment Record on latest official form provided by the Division of Water Quality (Groundwater Section) shall be completed. A copy of this completed form shall be sent to the County Health Department, NCDENR, and UTILITY.
- 3.9.3 **All unused wells must be abandoned to protect the integrity of the ground water supply.** It shall be at the discretion of the UTILITY to allow a well not being used for the community water system to be kept for irrigation or other purposes.

## Division 3

### Section 4

#### Plumbing

##### 4.1 Valve Bank

- 4.1.1 A valve bank shall be installed and sized in accordance with the approved plans and UTILITY's specifications. The valve bank shall be designed so that the maximum water velocity shall be 8 ft/sec. All Valves with be clock-wise closed and counter clock-wise open. All water valves within the Well House (whether main well house or satellite) shall be ¼ turn ball valves.
- 4.1.2 Only ASTM approved pipe shall be used above ground level as specified on the parts list.
- 4.1.3 Acceptable piping for below ground installations can be found on the materials list.
- 4.1.4 A turbine meter shall be installed on wells yielding more than 30 gpm water production. The turbine meter shall be capable of producing a 4-20 ma signal and shall also have a visual indicator showing the gallons per minute and total gallons pumped. Said meter size and model shall be specified by UTILITY.
- 4.1.5 A positive displacement meter of 1" size shall be used on wells producing 30 gpm or less. The meter shall be capable of producing a 4-20 ma signal and shall also have visual indicator showing the gallons per minute and total gallons pumped
- 4.1.6 Each valve bank shall have a WYE strainer installed before the water enters the meter. The WYE strainer shall be equipped with a ball valve and be piped to discharge at least 40 feet from the building to a ditch or the lowest point on the well lot. This drain shall not be installed in such a manner to cause flooding or standing water on the well lot. An air gap shall be maintained at the discharge end of the pipe. A rodent screen and splash block shall also be provided at the discharge end of this pipe.
- 4.1.7 When the plumbing is complete, all inside pipes 1" or smaller shall be insulated with rubber tube insulation such as Rubatex. All outside pipes and appurtenances shall be heat traced and insulated with rubber insulating tape such as Rubatex tape to a minimum thickness of 7/8" and covered with PVC pipe sized as follows:
- 2" or Smaller Pipe - 2" Rubatex & 4" Sch. 40 PVC
  - 4" or Smaller Pipe - 4" Rubatex & 6" Sch. 40 PVC
- 4.1.8 A ¼ inch ball valve with WOG rating of 600 psi shall be installed on all gauges.
- 4.1.9 Gauges of proper pressure rating as determined by UTILITY shall be oil filled.

- 4.1.10 Swing check valves, spring check valves, ball valves, and short stem gate valves shall meet a minimum of 200% of the operating systems pressure or the ASTM approved rating, whichever is greater.
- 4.1.11 A pressure switch shall be installed complete with 1/4" shut off, 1/4" drain and oil-filled gauge of the proper pressure.
- 4.1.12 One threaded hose bib equipped with a vacuum breaker shall be installed in the chemical feed equipment. An unthreaded sample tap shall be provided at the well head. One unthreaded sample tap shall be provided on the system side of the valve bank.
- 4.1.13 All blow off pipes shall be installed so that the water will drain to a ditch or the lowest area of the well lot. This drain shall not be installed in such a manner as to cause flooding or standing water on the well lot. An air gap and rodent screen shall be maintained at the discharge end of the pipe.
- 4.1.14 In compliance with \*OSHA 29 CFR 1910.151(c), emergency dual head eye wash units piped to the valve bank on the system side of the check valve will be located within the well house near the chemical equipment and near the entrance to the building. Drench hoses shall remain in operable condition at all times. The emergency eye wash heads will be located between 4 and 5 feet above the floor and attached to the wall per manufacturer specifications.
- 4.1.15 Coatings and Linings: Where ductile iron pipe and fittings are installed below grade or installed in a casing pipe, a bituminous coating approximately 1.0 mil thick shall be applied in accordance with ANSI/AWWA A21.51/C151. Where ductile iron pipe and fittings are to be installed aboveground, pipe, fittings and valves shall be thoroughly cleaned and given one field coat (minimum 1.5 mils dry thickness) of rust inhibitor primer. Intermediate and finished field coats of Alkyd shall also be applied by the CONTRACTOR (minimum 1.5 mils dry thickness each coat). Primer and field coats shall be compatible and shall be applied in accordance with the manufacturer's recommendations. Final field coat shall be olive green for raw water and dark blue for finished water.

All ductile iron pipe and fittings shall have an interior protective lining of cement-mortar with a seal coat of asphaltic material in accordance with ANSI/AWWA A21.4/C104

- 4.1.16 Distribution Pressure Relief Valve (PRV): On all systems containing hydropneumatic tanks as the storage and pressure regulating structure - A pressure relief valve shall be located within the well house and mounted on the piping such that it is exposed to the pressures as experienced by the distribution system. This PRV will be piped so that when activated it will discharge to the blow-off piping listed above.  
The PRV shall be factory set at 100 pounds per square inch and shall be a 2 inch flow model as manufactured by Kunkle with the capability of discharging water in a range from 19 gallons per minute (gpm) to 229 gallons per minute. The PRV shall be built as follows:

All Bronze with Pressure tight cap  
Both inlet and outlet connections will be cast integral with body to permit easy inspection and servicing without disconnecting piping.  
Beveled seats lapped for optimum performance.

Stainless Steel (SS) spring for optimum corrosion resistance  
Working pressure rated from 1 to 300 psig  
Temperature rated from -60 to 406 degrees Fahrenheit

If the well pump or pumps within the system have an approved capacity to exceed 200 gpm, then multiple valves or larger valves must be evaluated. The discharge capacity of the valve(s) must meet the well pump(s) approved pumping capacity.

This valve will be installed behind a ¼ turn ball valve as shown in the details.

## **4.2 Hydropneumatic Tank**

- 4.2.1 The contractor will plumb in the hydropneumatic tank, including but not limited to, the supply line, discharge line, air compressor piping, pressure relief, vacuum breakers, etc., (in accordance with the utility drawing.) and shall provide protection from freezing for these items.
- 4.2.2 The supply main will be of new ASTM approved pipe, complete with 90-degree ell, unions, etc. Where the tank is set on prefab saddles, a mechanical joint dresser coupling shall be provided ahead of tank connection to allow for settling.
- 4.2.3 One Well System - A 2" blow-off assembly complete with square nut cast valve and a cut off valve between the blow-off assembly and the tank shall be installed. A 2" galvanized or brass coupling shall be left within 3" of the top of the blow-off valve box for future connections (in accordance with the Utility drawing).
- 4.2.4 Multiple Tank Systems - A tank bypass of the proper size shall be installed on systems with more than one hydro-pneumatic tank and on potential elevated tank systems with hydro-pneumatic tank, complete with tank and main cutoff valves (in accordance with the Utility drawing).
- 4.2.5 The relief valve shall be a side discharge of pressure rating and size as per UTILITY specifications and shall be mounted on the top of the tank and will insulated to prevent freezing.
- 4.2.6 The vacuum breaker shall be a minimum 3/4" installed as shown in accordance to the utility drawing.
- 4.2.7 A ball valve with 600 WOG rating and a ball valve with a locking device shall be installed between the tank and the pressure relief valve and vacuum breaker (in accordance with the Utility drawing).

## **4.3 Air Compressor**

- 4.3.1 An air compressor shall be installed complete with necessary piping and fittings.
- 4.3.2 Air compressor shall be of sufficient pressure to overcome the system cut-off pressure

while providing a minimum of .5cfm of free air. Controls shall be provided to start and stop the compressor due to water levels and pressures.

- 4.3.3 Probes used for air compressors shall be set at 6" above the center of the hydro-pneumatic tank. The air compressor safety cut off shall be set 2 psi above the system cut off pressure.
- 4.3.4 When used, the air volume control shall be placed so as to maximize the drawdown of the hydro-pneumatic tank during cycles.
- 4.3.5 All pipe in conjunction with air compressor shall be thoroughly cleaned to remove any cuttings or oil that might be left from cutting and threading of pipe.

#### **4.4 Ground Storage Tanks**

- 4.4.1 Inlet and outlet fittings shall be located, sized, and of the type specified by the UTILITY and designed to promote turnover in the tank.

#### **4.5 Distribution**

- 4.5.1 The distribution line shall be C900 DR 14 PVC or ductile iron as specified by the UTILITY, complete with mechanical joint fittings, ductile iron spools (inc. attached to the bottom flange of the tank), flange adapter, reducers, etc. A locating wire 30 mil HDPE jacket or larger, shall be attached to the locating wire left by the distribution system contractor and run with the pipe, the end terminating at the top of the valve box or under the tank. All underground pipes shall have a minimum cover of 3' with the first 18" of fill free of rocks and debris. Concrete blocking or approved restraint fittings shall be provided behind all ells and tees as per AWWA standards (in accordance with the utility drawing.)

## Division 3

### Section 5

#### Storage Tanks

##### 5.1 Hydropneumatic Storage Tanks

- 5.1.1 Hydropneumatic tank shall be constructed and stamped in accordance with the American Society of Mechanical Engineers (ASME) Pressure Vessel Code stamped with the ASME "U" symbol stamp and registered with the National Board of Boiler and Pressure Vessel Inspectors. These tanks must be inspected by the Department of Labor, Boiler and Pressure Vessel Division after installation but prior to operation. Tank shall be manufactured to UTILITY's specifications and have a rated working pressure of at least 125 psi. Size of tank with number and size of outlets will be specified by the UTILITY. The minimum size tank accepted by UTILITY for a community water system shall be 5,400-gallons
- 5.1.2 The contractor shall set tank complete with pedestals as per plans.
- 5.1.3 Pedestals shall be excavated to solid compact ground (at least 36" below ground) and poured of 3,500 psi concrete (or 3,000 psi concrete with an additive) to form to the tank with a 12" dip at the center. Alternatively, steel saddles may be used to cradle the tank and shall sit firmly on top of the concrete pedestals. Pedestals shall be set on solid, compact ground with a minimum bearing capacity of 2500 psf. The first pedestal shall be no further than 10' from the house without UTILITY approval. The width shall be 2' with a length of 6' for 5,400-gallon tanks. The width shall be 30" with a length of 8' and a depth of 48" for 10,000-gallon tanks. Pedestals for other tank sizes shall be as specified by UTILITY. Forms shall be removed after 48 hours. Pedestal finish shall be smooth. The bottom of the tank shall be 18" above finish elevation of the ground beneath it.
- 5.1.4 Before setting the tank, the tank shall be painted with the appropriate finish and allowed to dry for 7 days. [Tank Coating shall comply with AWWA D102](#). The two surfaces must be separated by a rubber or dense polypropylene material as specified by UTILITY. See Division 3 Section 7 for appropriate materials.
- 5.1.5 The tank shall be air cured for a minimum of 14 continuous days before filling.
- 5.1.6 The tank shall be thoroughly flushed to remove any sediment or foreign matter. A chlorine solution, in concentrations sufficient to produce a chlorine residual of at least 50-ppm, shall be introduced to overflow the tank. The chlorine solution shall remain in contact with the interior surfaces for a period of 24 hours. The tank then shall be thoroughly flushed with the free chlorine residual solution not to exceed 2 ppm after flushing. The tank shall not be placed into service until bacteriological test results are found to be satisfactory.

##### 5.2 Ground Level Storage Tanks

- 5.2.1 Ground storage tank shall be installed in accordance with the design specifications completed by a licensed engineer in the State of North Carolina. Said design shall be approved by UTILITY and shall comply with all County, State, and Federal requirements. Ground Storage tanks shall be constructed in accordance with the American Society of Mechanical Engineers (ASME) Code. Tanks shall be manufactured to UTILITY specifications and size.
- 5.2.2 Design and its fabrication must comply with AWWA Standards D 100 of the American Water Works Association, Inc. Tank Coating shall comply with AWWA D102. Foundations and support structures must comply with standard ACI 318. All accessory items installed shall be in full conformity with the current applicable OSHA safety regulations and the operating requirements of the structure. At a minimum if the tank is taller than 8 feet, a fixed ladder or form of access/egress must be installed in accordance with OSHA and AWWA standards and recommendations.
- 5.2.3 The Contractor shall provide working drawings and design calculations for the tank and the foundation. Drawings shall show the size and location of all structural components and reinforcement, the required strength and grade of all materials and the size and arrangement of principle piping and equipment. The drawings and calculations shall bear the certification of a professional Engineer licensed in the State of North Carolina.
- 5.2.4 A sanitary, screened vent and overflow of the proper size shall be installed on the top of the tank.
- 5.2.5 Probes of 316 stainless steel and all necessary controls for operation and monitoring of the water levels shall be installed in accordance with the UTILITY specifications and/or the approved plans. The number and settings for these probes shall be determined by the UTILITY and/or the approved plans.
- 5.2.6 The tank shall be all-welded construction of the most economical design. All members of structural steel shall be designed to safely withstand the maximum stresses to which they may be subjected during erection and operation.

## Division 3

### Section 6

#### Well House

##### 6.1 Pad

- 6.1.1 The well house pad at minimum shall measure 10' x 10' by 6-inches thick. The footer and the slab shall be a continuous pour. The pad and foundations shall meet the international building code and all state and local regulations as it pertains to the appropriate building structure, at a minimum it shall be constructed as shown in the Standard Details.. The wellhead pad shall extend a minimum of 8' 6" from well house pad and allow for a continuous bond concrete extending three feet horizontally around the outside of the well casing as per plans.
- 6.1.2.1 The well house pad shall be a minimum of 6" thick with 12" X 12" footings and a 1/2" slope to the drains. Concrete shall have a compressive strength of 3,000 psi.
- 6.1.2.2 The wellhead concrete pad shall be 8" thick with 12" x 12" footings and join with the well grout. Forms shall be level and square.
- 6.1.2 A 4" floor drain with pea-trap shall be installed in the center of the well house. The under-floor piping shall be Schedule 40 PVC. It shall be installed with a 0.5 % slope. The top of the pipe shall have a minimum of 12" of cover, and it shall extend a minimum of 20' away from the well house or as directed by UTILITY. No standing water shall be allowed. Necessary measures including ditching and riprap may be required depending in site conditions.
- 6.1.3 Finished elevation of the pad shall be 3" to 4" above the surrounding ground and the site shall be graded so as not to allow runoff water to enter the building.
- 6.1.4 The edges of the pad shall be smooth.
- 6.1.5 Concrete shall be poured and installed in accordance with industry standards.
- 6.1.6 After the pad is poured and has set for at least 24 hours, forms shall be dismantled and removed from the site.
- 6.1.7 No slab penetrations shall be allowed except wellhead and drain. All additional piping shall be routed outside of building footprint prior to burying.

##### 6.2 Block

- 6.2.1 A row of 6" block is required around the perimeter of the building complete with 3/8"



anchor bolts as per plans for wood framed well houses or in accordance with local permitting standards.

- 6.2.2 Blocks and mortar joints shall be level and free of cracks and shall be filled with concrete.

### **6.3 Wood Building**

- 6.3.1 The contractor shall build house complete with a 36", single, aluminum, powder coated, exterior door as per Well House Framing Detail (See Drawing W-31).

- 6.3.2 Pressure treated 2" x 6" lumber shall be used as the seal plate and bolted to the anchor bolts or in accordance with County standards.

- 6.3.3 Joists shall be on 16" centers.

- 6.3.4 Ceiling joists shall be a minimum of 8' above finished floor.

- 6.3.5 Siding shall be 5 1/4" x 8" x 5/16" fiber cement board (or approved equal), installed per manufacturer's recommendations. Color to be selected by UTILITY (see Division 3 Section 7.2). Alternatives will be submitted to UTILITY for approval.

- 6.3.6 The well cover house shall be 24" above finished block to the top of the wall. Well cover size shall not exceed 36" wide and 7' long.

- 6.3.7 A gable vent or ridge vent shall be installed with a soffit vent for proper roof ventilation.

- 6.3.8 Two - 8" x 16" automatic foundation vents with wire security grating shall be installed 6" above the block on the back sides of the well house. Two 8" x 16" closing vents shall be installed in the front ceiling to allow heat to dissipate out through the roof in the summer.

- 6.3.9 Hasps shall be installed on well cover roof.

- 6.3.10 If building is to be built of any material other than wood, plans shall be approved by UTILITY in writing.

- 6.3.11 Interior Walls shall be backed with faced batt insulation and finished out with 1/2" plywood and painted white.

- 6.3.12 A well head protection sign (provided by UTILITY) shall be installed on each well house as well as a well identification number.

### **6.4 Roofs**

- 6.4.1 A gable style roof shall be built with 4/12 pitch.

- 6.4.2 Covering shall be 1/2" OSB with 30# felt paper and (golden or autumn brown) architectural shingles with 20-year warranty.

- 6.4.3 Well cover roof shall be removable by sliding and flashed with 1.5" x 1.5" angle iron to

house.

6.4.4 All eaves shall be boxed in. Fascia shall be constructed of fiber cement board.

6.4.5 Metal drip edge material shall be installed at all exposed edges of the roof decking.

## **6.5 Insulation**

6.5.1 All wood houses shall be constructed with R-15 faced batt insulation in the walls and R-30 fiberglass insulation in the ceilings. Construction in Alleghany, Ashe, Avery, Mitchell, and Yancey counties require R-19 fiberglass insulation in walls.

6.5.2 All block houses shall have insulation poured to the top of the block in each block cavity.

## **6.6 Commercial Size Well Houses**

6.6.1 If structure is larger than 144 square feet, it shall comply with all local fire regulations (i.e. access road, address, fire extinguisher, etc.)

## **6.7 Satellite Well Houses**

6.7.1 Installation of a satellite well house shall be at the discretion of the UTILITY.

6.7.2 Please refer to the Satellite Well House cut sheets attached to these specifications for complete construction details.

## Division 3

### Section 7

#### Painting

##### 7.1 Paint Products

- 7.1.1 Materials specified are those that have been approved by the UTILITY. Products of the Sherwin Williams Company and the Tnemec Company are listed to establish a standard of quality. Equivalent materials of other manufacturers may be substituted on written approval of the UTILITY.
- 7.1.2 Requests for substitution shall include manufacturer's literature for each product giving the name, product number, generic type, descriptive information, solids by volume, recommended dry film thickness, and manufacturer's color charts.
- 7.1.3 Requests for substitution shall be submitted for approval at least 30 days prior to paint application.

##### 7.2 Houses

- 7.2.1 Wood houses shall have at least two coats of Sherwin Williams A-100, latex flat exterior Plantation Brown paint applied to house and the trim.
- 7.2.2 Blockhouses shall be sealed and then have two coats of Sherwin Williams latex flat exterior A-100 Plantation Brown 90224.

##### 7.3 New Hydro-pneumatic Tanks

- 7.3.1 Interior - Epoxy
  - 7.3.1.1 Surface Preparation: Steel Structures Painting Council (SSPC) SP10, Near White Metal Blasting Cleaning. After surface preparation and prior to painting, all unwelded seams will be filled with Tnemec Series 63-1500 Filler and Surfacer.
  - 7.3.1.2 1st Coat: Tnemec Series N140F-1255 Beige Pota-Pox primer at 4 dry mils per manufacturer's recommendation.
  - 7.3.1.3 2nd Coat: Tnemec Series N140F-00 Tank White Pota-Pox finish at 5 dry mils per manufacturer's recommendation. After installation of final coat, interior shall be force cured for a minimum 24 hours with heated air.
  - 7.3.1.4 A minimum of fourteen (14) days cure time shall be allowed before being placed into service.

7.3.1.5 Manufacturer approved thinners for specific Series and applications shall be used. Total dry film thickness shall be a minimum 9 dry mils per SSPC dry film thickness measuring standards.

7.3.2 Exterior - Epoxy / Polyurethane

7.3.2.1 Surface preparation: Steel Structures Painting Council (SPCC) SP10, Near White Metal Blast Cleaning.

7.3.2.2 1st Coat: Tnemec Series N14F-1255 Beige Pota-Pox Primer at 3.0 dry mils.

7.3.2.2 2nd Coat: Tnemec Series 1074 Endura-Shield (Color 84BR Weathered Bark) at 4.0 dry mils.

7.3.2.3 3rd Coat: Tnemec Series 1074U Endura-Shield (Color 84BR Weathered Bark) at 3.0 dry mils.

7.3.2.4 A minimum of seven (7) days cure time shall be allowed before placing into service.

7.3.2.5 Manufacturer approved thinners for specific Series and applications shall be used. Total dry film thickness of the new system shall be a minimum 10 dry mils.

7.3.3 Cathodic Separation protection

Cathodic Protection Material of  $\frac{3}{4}$  inches minimum thickness shall be placed between the tank and the pedestals. This material will be wide enough and long enough to cover any areas that the tank and pedestals could possibly come into contact with each other.

7.3.4 Disinfection

All Hydro-pneumatic tanks shall be disinfected in accordance with North Carolina State Regulations and pass a bacteriological test.

A VOC sample may be collected by the UTILITY at its discretion.

## Division 3

### Section 8

#### Electrical

- 8.0 Maintenance Employee Safety is of the utmost importance. When devices are engineered and available that could limit incidents such as Arch-Flash, then equipment, panels, and boxes with design features built into them will be specified and used.
- 8.1 All electrical work shall be installed under a licensed electrician and shall pass all local and State inspection requirements.
- 8.2 **Services**
- 8.2.1 All new installations shall be equipped with power service.
- 8.2.2 Only copper conductors will be accepted for the service.
- 8.2.3 A grounding electrode of adequate size shall be connected to the well casing with two (2) driven electrode rods of 3/4" Minimum diameter. Driven grounding Rods shall be at least ten (10) feet apart. A ground test shall be performed and data presented to the UTILITY to insure adequate grounding is achieved.
- 8.2.4 All services shall have a minimum 200-amp meter base.
- 8.3 **Panels**
- 8.3.1 All control panels, transfer switches, meter, bases, branch circuit panels, electric boxes, motor control boxes, etc shall be NEMA rated as follows:
- Located/mounted in the interior of a wellhouse/building shall be NEMA 4X
- Located/mounted on the exterior of a wellhouse/building/remote well site (even if under a shed or building roof overhang) shall be NEMA 4X
- 8.3.2 Main well house panel shall be as specified by the UTILITY in Section 5, and shall be interior, surface mounted with a main breaker of specified size with a minimum of 16 circuits. Panels shall be a minimum of 200 Amp rated and include a NEMA 4X enclosure as specified above. Panels shall be ITE with copper busway.
- Remote well house panels shall be identical to above in amp size, ITE with copper busway and minimum circuit rating. It shall be mounted in according to the Standard details and shall be NEMA Rated as listed above.
- 8.3.3 Each panel shall be provided with lightning arresters, Cutler Hammer CHS-A01 or equal.
- 8.3.4 When wiring is finished, the panel shall be labeled as to which breaker feeds what load.

- 8.3.5 Wiring loads shall be balanced in panels.
- 8.3.6 One 20 ampere single pole breaker shall be installed as a spare in each panel.
- 8.3.7 All electrical outlets shall be protected by GFI breakers.

#### **8.4 Magnetic Starters**

- 8.4.1 As specified in Section 5, NEMD standard, with hand off/automatic (HOA) and an indicator light shall be used unless otherwise approved by the UTILITY. An Intermatic Model FF5M spring wound 5 minute timer switch shall be installed with a permanently marked cover to control the “auto-on” of the pump.
- 8.4.2 Each starter shall have two sets of normally open auxiliary contacts provided.
- 8.4.3 An adequate thermal overload shall be provided in each leg of the starter, as specified in the pump and motor manufacturer’s specification book or attached chart.
- 8.4.4 Size of the starter will be determined by UTILITY.
- 8.4.5 Magnetic starts shall be Allen Bradley, NEMA 3R with 120 VAC coil.

#### **8.5 Pressure Switches**

If required, an Allen Bradley 835T-T253J (or UTILITY-approved equivalent) pressure switch will be installed.

#### **8.6 Indicating Controls**

An elapsed time meter and an impulse counter shall be mounted and wired by the contractor. Said elapsed time meter and impulse counter shall be selected from the attached materials list.

#### **8.7 Telemetry/Radio Controls**

- 8.7.1 If required, telemetry and/or radio controls will be designed and installed as approved by UTILITY at UTILITY’s cost.
- 8.7.2 .UTILITY will pay for any SCADA equipment required.

#### **8.8 Air Compressor**

Where a hydro-pneumatic tank is installed, a compressor and controls shall be installed. Said compressor shall be selected from the attached parts list specified by UTILITY.

#### **8.9 Chemical Receptacle**

Three discrete circuit 115 VAC duplex GFI/GFCI receptacles shall be installed as shown in the Standard Details or as specified by the UTILITY. These receptacle outlets shall be permanently marked as “chemical”.

### **8.10 Utility Receptacles**

Two 115 VAC utility receptacle that are energized constantly and protected by a ground fault interrupter in addition to the breaker shall be installed. These receptacle outlets shall be permanently marked as "utility". One shall be located on the chemical panel side of house and one shall be located on the electrical panel side of house.

### **8.11 Lights**

One LED vapor-tight ceiling mount fixture manufactured by LSI industries, model EG34SLEDHOCWUSEL, or equal, is required in each well house and shall be controlled from a wall switch at the entrance.

### **8.12 Heating**

8.12.1 For a standard 10 X 10 well house, there shall be one four-foot 1,000-watt 240 volts AC baseboard heater mounted 6" above block on the interior wall. If the building is larger, then additional heating may be required.

8.12.2 The baseboard heater shall be controlled by a remote bulb thermostat. Thermostat shall be manufactured by White-Rodgers, Model #2B61-186.

8.12.3 If more than one baseboard heater is required baseboard heaters shall be substituted with one 3.3 kW unit heater.

### **8.13 Wire**

8.13.1 All wire shall be copper of THW or THHN type and of adequate size.

### **8.14 Raceways**

8.14.1 All raceways underground shall be minimum 2" schedule 40 PVC.

8.14.2 All exposed conduit shall be a sized according to conduit fill with exception of service masts which shall be of 2" rigid conduit.

8.14.3 Liquid tite flex or Carflex with the proper fittings shall be used from the well to the junction boxes, etc.

8.14.4 One hole or minerallic straps shall be used on all raceways in accordance with the N.E.C.

8.14.5 All building interior conduit shall be PVC

### **8.15 Fittings**

8.15.1 PVC FS switch boxes shall be used for receptacles and switches.

8.15.2 Boxes and Fittings used with PVC pipe shall be of the PVC type.

### **8.16 Manual Transfer Switch**

- 8.16.1 Equipment shall conform to the requirements of NFPA 70.
- 8.16.2 Products shall be listed and classified by UL or other North Carolina Recognized Third Party Testing Agency.
- 8.16.3 Equipment shall be NEMA ICS 10, manual transfer switch suitable for use as service equipment. Load side lugs shall be suitable for connection of two conductors per phase. The second set of conductors will be #6 AWG for connection to a surge protective device.
- 8.16.4 Ratings shall be for 480 volts, three phase, four wire, 60 Hz. 400A continuous rating or greater.
- 8.16.5 Enclosure shall be NEMA ICS 6, Type 3X.
- 8.16.6 Generator connections shall be installed in the base of the transfer switch. The connectors shall be Hubbell Single Pole Receptacles meeting the following:

- 400-amp panel mount
- Mates with 300 or 400-amp plugs
- Rated to 600 volts
- Contact material shall be brass

Color sequence AND receptacle designations shall be as follows – Left to Right facing the transfer switch:

Single Phase installations:

Blue Male Receptacle, Black Male Receptacle, Green FEMALE Receptacle

Three Phase Installations:

Blue Male Receptacle, Orange Male Receptacle, Black Male Receptacle, Green FEMALE Receptacle



## Division 3

### Section 9

#### Excavation, Backfill, Compaction, Grading, & Restoration

##### 9.1 General

This Section covers excavation, backfill, compaction, grading and restoration associated with utility trench and structural construction. All such WORK shall be performed by the CONTRACTOR concurrently with the WORK specified in these SPECIFICATIONS. The CONTRACTOR shall furnish all labor, materials, equipment and incidentals necessary to perform all excavation, backfill, fill, compaction, grading and slope protection required to complete the WORK shown on the DRAWINGS and specified herein. The WORK shall include, but not necessarily be limited to: pump stations, manholes, vaults, conduit, pipe, roadways and paving; all backfilling, fill and required borrow; grading; disposal of surplus and unsuitable materials; and all related WORK such as sheeting, bracing and water handling.

##### 9.2 Soil Borings and Subsurface Investigations

Subsurface exploration and geotechnical engineering evaluation where provided is for the CONTRACTOR'S information only. Data on indicated subsurface conditions are not intended as representations or warranties of accuracy or continuity between soil borings.

The CONTRACTOR shall examine the site and undertake additional subsurface investigations including soil borings, if so desired, before commencing the WORK. UTILITY will not be responsible for presumed or existing soil conditions in the WORK area.

##### 9.3 Existing Utilities

CONTRACTOR shall locate existing utilities in the areas of WORK. If utilities are to remain in place, the CONTRACTOR shall provide adequate means of protection during earthwork operations. Should uncharted or incorrectly charted piping or other utility conflicts encountered during excavation, the CONTRACTOR shall consult the owner of such piping or utility immediately for directions. Payment for damage and repair to such piping or utilities is the contractor's responsibility. Refer to Section 10.2 for utility coordination requirements.

UTILITY shall not be responsible for uncharted or incorrectly charted water and wastewater mains or other utilities. It is the contractor's responsibility to ensure that such facilities exist at the presumed point prior to commencing construction.

##### 9.4 Materials

9.4.1 General: Materials for use as bedding and backfill, whether in-situ or borrow, shall be as described under this Section. The CONTRACTOR shall upon request by UTILITY, make an appropriate sample of this material available for testing by UTILITY or its

designated representative.

- 9.4.2 **Structural Fill:** Materials for structural fill shall be bedding rock or select common fill as specified herein or other suitable material as approved by UTILITY.
- 9.4.3 **Common Fill:** Common fill shall consist of material substantially free of organic material, loam, wood, trash and other objectionable material which may be compressible or which cannot be compacted properly. Common fill shall not contain stones larger than 4 inches in any dimension, asphalt, broken concrete, masonry, rubble or other similar materials. It shall have physical properties such that it can be readily spread and compacted during filling. Additionally, common fill shall be no more than 12 percent by weight finer than the No. 200 mesh sieve unless finer material is approved for use in a specific location by UTILITY.
- 9.4.4 **Select Common Fill:** Select common fill shall be as specified above from common fill, except that the material shall contain no stones larger than 1-1/2 inches in largest dimension, and shall be no more than 5 percent by weight finer than the No. 200 mesh sieve.
- 9.4.5 **Bedding Rock:** Bedding rock shall be 3/16 inch to 3/4 inch washed and graded stone (NCDOT #57). This stone shall be graded so that 90 to 100 percent will pass a 3/4 inch screen and 95 to 100 percent will be retained on a No. 8 screen. No stones larger than 1 inch in any dimension shall be accepted.

## 9.5 Dewatering, Drainage and Flotation

- 9.5.1 **General:** The CONTRACTOR shall excavate, construct and place all pipelines, concrete work, fill, and bedding rock, in-the-dry. In addition, the CONTRACTOR shall not install the final 24-inches of excavation until the water level is a minimum of one foot below the proposed bottom of excavation. For purposes of these SPECIFICATIONS, "in-the-dry" is defined to be within 2% of the optimum moisture content of the soil. UTILITY reserves the right to ask the CONTRACTOR to demonstrate that the water level is a minimum of one foot below proposed bottom of excavation before allowing the construction to proceed.

Discharge from dewatering shall be disposed of in such a manner that it will not interfere with the normal drainage of the area in which the WORK is being performed, create a public nuisance, or form ponding. No flooding of streets, driveways or private property will be permitted. The operations shall not cause injury to any portion of the WORK completed, or in progress, or to the surface of streets, or to private property. The dewatering operation shall comply with the requirements of appropriate regulatory agencies. Additionally, where private property will be involved, advance permission shall be obtained by the CONTRACTOR. Engines driving dewatering pumps shall be equipped with residential type mufflers. Where feasible, electrical "drops" shall be used in lieu of portable generators.

- 9.5.2 **Additional Requirements:** The CONTRACTOR shall, at all times during construction, provide and maintain proper equipment and facilities to remove promptly and dispose of properly all water entering excavations. The CONTRACTOR shall keep such excavations dry so as to obtain a satisfactory undisturbed subgrade foundation condition until the fill, structure, or pipelines to be built thereon have been completed.

Dewatering shall at all times be conducted in such a manner as to preserve the natural undisturbed bearing capacity of the subgrade soils at the proposed bottom of the excavation.

It is expected that wellpoints will be required for pre-drainage of the soils prior to final excavation for some of the deeper in-ground structures or piping and for maintaining the lowered groundwater level until construction has been completed to such an extent that the structure, pipeline or fill will not be floated or otherwise damaged. Wellpoints shall be surrounded by suitable filter sand and negligible fines shall be removed by pumping.

The CONTRACTOR shall furnish all materials and equipment and perform all work required to install and maintain the drainage systems for handling groundwater and surface water encountered during construction of structures, pipelines and compacted fills.

If required during backfilling and construction, water levels shall be measured in observation wells located as directed by UTILITY.

Continuous pumping will be required as long as necessary until completion of below grade activity.

## **9.6 Excavation**

9.6.1 Excavation for Structures: All such excavations shall conform to the elevations and dimensions shown on the DRAWINGS within a tolerance of plus or minus 0.10 feet and extending a sufficient distance from footings and foundations to permit placing and removal of formwork, installation of services and other construction, inspection or as shown on the DRAWINGS. In excavating for footings and foundations, care shall be exercised not to disturb the bottom of the excavation. The bottom of excavations shall be rendered firm and dry before placing any structure or concrete.

9.6.2 Trench Excavation: Excavation for all trenches required for the installation of utility pipes shall be made to the depths indicated on the DRAWINGS and in such manner and to such widths as will give suitable room for installing the pipe within the trenches, for bracing and supporting and for pumping and drainage facilities.

The bottom of the excavations shall be firm and dry and in all respects acceptable to UTILITY.

Excavation shall not exceed normal trench width or depth as specified in the STANDARD DETAILS. Any excavation which exceeds the normal trench depth shall require special backfill requirements as determined by UTILITY.

Where pipes are to be installed on bedding rock, select common fill or encased in concrete, the trench may be excavated by machinery to or just below the designated subgrade provided that the material remaining in the bottom of the trench is no more than slightly disturbed.

Where pipes are to be installed directly on the trench bottom, the lower part of the trenches shall not be excavated to grade by machinery. The last of the material being

excavated shall be done manually in such in a manner that will give a shaped bottom, true to grade, so that pipe can be evenly supported on undisturbed material, as specified in the STANDARD DETAILS. Bell holes shall be made as required.

## **9.7 Bedding and Backfill**

- 9.7.1 General: Material placed in fill areas under and around structures and pipelines shall be deposited within the lines and to the grades shown on the DRAWINGS or as directed by UTILITY, making due allowance for settlement of the material. Fill shall be placed only on properly prepared surfaces which have been inspected and approved by UTILITY. If sufficient select common or common fill material is not available from excavation on site, the CONTRACTOR shall provide fill as may be required.

Fill shall be placed and spread in layers by a backhoe or other approved method, unless otherwise specified. Prior to the process of placing and spreading, all materials not meeting those specified under Division 3, Section 9.4 shall be removed from the fill areas. The CONTRACTOR shall assign a sufficient number of men to this WORK to insure satisfactory compliance with these requirements.

All fill materials shall be placed and compacted "in-the-dry." The CONTRACTOR shall dewater excavated areas as required to perform the work and in such manner as to preserve the undisturbed state of the natural inorganic soils.

Prior to filling, the ground surface shall be prepared by removing vegetation, debris, unsatisfactory soil materials, obstructions and deleterious materials. CONTRACTOR shall plow strip or break up sloped surfaces steeper than one vertical to four horizontal so that fill material will bond with the existing surface. When existing ground surface has a density less than that specified under Division 3, Section 12.9 for the particular area classification, CONTRACTOR shall break up the ground surface, pulverize, moisture-condition to the optimum moisture content and compact to required depth and percentage of maximum density.

Before compaction, material shall be moistened or aerated as necessary to provide the optimum moisture content. Material which is too wet shall be spread on the fill area and permitted to dry, assisted by harrowing if necessary, until the moisture content is reduced to allowable limits. If added moisture is required, water shall be applied by sprinkler trucks or other sprinkler systems, which will insure uniform distribution of the water over the area to be treated and give complete and accurate control of the amount of water to be used. If too much water is added, the area shall be permitted to dry before compaction is continued. The CONTRACTOR shall supply all hose, piping, valves, sprinklers, pumps, sprinkler trucks, hauling equipment and all other materials and equipment necessary to place water on the fill in the manner specified. CONTRACTOR shall compact each layer to required percentage of maximum dry density or relative dry density in accordance with Division 3, Section 9.9. Backfill or fill material shall not be placed on surfaces that are muddy, frozen or contain frost or ice.

- 9.7.2 Bedding and Backfill for Structures: Bedding rock shall be used for bedding under all structures as indicated on the STANDARD DETAILS. The CONTRACTOR shall take all precautions necessary to maintain the bedding in a compacted state and to prevent washing, erosion or loosening of this bed. Structural fill shall be used as backfill against the exterior walls of the structures. Fill shall be compacted sufficiently in accordance

with Division 3, Section 9.9.2 of these SPECIFICATIONS. If compaction is by rolling or ramming, material shall be wet down as required.

Backfilling shall be carried up evenly on all walls of an individual structure. No backfill shall be allowed against walls until the walls and their supporting slabs, if applicable, have attained sufficient strength.

In locations where pipes pass through building walls, the CONTRACTOR shall take precautions to consolidate the fill up to an elevation of at least one (1) foot above the bottom of the pipes. Structural fill in such areas shall be placed for a distance of not less than three (3) feet either side of the center line of the pipe in level layers not exceeding eight (8) inches in depth.

The surface of filled areas shall be graded to smooth true lines, strictly conforming to grades indicated on the DRAWINGS. No soft spots or uncompacted areas will be allowed in the WORK.

Temporary bracing shall be provided as required during construction of all structures to protect partially completed structures against all construction loads, hydraulic pressure and earth pressure. The bracing shall be capable of resisting all loads applied to the walls as a result of backfilling.

- 9.7.3 Bedding and Backfill for Pipes: Bedding for pipe shall be as shown on the PLANS and detailed on the STANDARD DETAILS. The CONTRACTOR shall take all precautions necessary to maintain the bedding in a compacted state and to prevent washing, erosion or loosening of this bed.

Backfilling over and around pipes shall begin as soon as practicable after the pipe has been installed, jointed and inspected. All backfilling shall be prosecuted expeditiously and as detailed on the STANDARD DETAILS.

Any space remaining between the pipe and sides of the trench shall be carefully backfilled and spread by hand or approved mechanical device and thoroughly compacted with a tamper as fast as placed, up to a level of one (1) foot above the top of the pipe. The filling shall be carried up evenly on both sides. Compaction shall be in accordance with the STANDARD DETAILS and Division 3, Section 9.9.

The remainder of the trench above the compacted backfill (as just described above) shall be filled and thoroughly compacted in uniform layers. Compaction shall be in accordance with the STANDARD DETAILS and Division 3, Section 9.9.

## **9.8 Compaction**

- 9.8.1 General: The CONTRACTOR shall control soil compaction during construction to provide the percentage of maximum density specified. The CONTRACTOR shall provide UTILITY copies of all soils testing reports prepared by a GEOTECHNICAL/SOILS ENGINEER, demonstrating compliance with these SPECIFICATIONS.

When existing trench bottom has a density less than that specified under Division 3, Section 9.9.2, the CONTRACTOR shall break up the trench bottom surface, pulverize,

moisture-condition to the optimum moisture content and compact to required depth and percentage of maximum density.

- 9.8.2 Percentage of Maximum Density Requirements: Fill or undisturbed soil from the bottom of the pipe trench to 1 foot above the pipe shall be compacted to a minimum density of 95% of the maximum dry density as determined by AASHTO T-180.

Non-Paved Areas: Backfill from 1 foot above utility pipe to grade shall be compacted to a minimum density of 95% of the maximum dry density as determined by AASHTO T-180.

Paved Areas: Backfill from 1 foot above utility pipe to bottom of subgrade shall be compacted to a minimum density of 98% of the maximum dry density as determined by AASHTO T-180.

Fill under and around structures, and to the extent of the excavation shall be compacted to a minimum density of 95% of the maximum dry density as determined by AASHTO T-180.

- 9.8.3 Compaction Tests: If the UTILITY deems it necessary, compaction tests can be required. The locations of compaction tests within the trench shall be in conformance with the following schedule, as determined by the UTILITY:

- One test at the spring line of the pipe.
- At least one test for each 12" layer of backfill within the pipe bedding zone for pipes 24 inches and larger.
- One test at an elevation of one foot above the top of the pipe.
- One test for each two feet of backfill placed from one foot above the top of the pipe to finished grade elevation.

If based on GEOTECHNICAL/SOILS ENGINEER testing reports and inspection, fill which has been placed is below specified density, CONTRACTOR shall provide additional compaction and testing prior to commencing further construction.

## 9.9 Topsoil

- 9.9.1 Strip topsoil from within limits of earthwork operations as specified. Topsoil shall be a fertile, friable, natural topsoil of loamy character and characteristic of locality. Topsoil shall be capable of growing healthy horticultural crops of grasses. Stockpile topsoil and protect as directed by Resident Engineer. Eliminate foreign materials, such as weeds, roots, stones, subsoil, frozen clods, and similar foreign materials larger than 1/2 cubic foot in volume, from soil as it is stockpiled. Retain topsoil on station. Remove foreign materials larger than 50 mm (2 inches) in any dimension from topsoil used in final grading. Topsoil work, such as stripping, stockpiling, and similar topsoil work shall not, under any circumstances, be carried out when soil is wet so that the composition of the soil will be destroyed.

- 9.9.2 Topsoil shall be uniformly redistributed in a 4-8-inch layer and lightly compacted to a minimum thickness of 4 inches. Any irregularities in the surface resulting from topsoiling or other operations shall be corrected in order to prevent formation of depressions or

water pockets. Topsoil shall not be placed while in frozen or muddy condition, when subsoil is excessively wet or in and condition detrimental to proper grading.

9.9.3 Erosion and sedimentation controls must be maintained when applying topsoil.

## 9.10 Grading

All areas within the limits of construction, including transition areas, shall be uniformly graded to produce a smooth uniform surface. Areas adjacent to structures or paved surfaces shall be graded to drain away from structures and pavement. Ponding shall be prevented. After grading, the area shall be compacted to the specified depth and percentage of maximum density.

No grading shall be done in areas where there are existing pipelines that may be uncovered or damaged, until such lines have been relocated.

## 9.11 Maintenance

CONTRACTOR shall protect newly graded areas from traffic and erosion and keep them free of trash and debris. CONTRACTOR shall repair and reestablish grades in settled, eroded and rutted areas.

Where completed compacted areas are disturbed by subsequent construction operations or adverse weather, CONTRACTOR shall scarify surface, reshape and compact to required density prior to further construction.

## 9.12 Inspection and Quality Assurance

9.12.1 Inspection: CONTRACTOR shall examine the areas and conditions under which excavating, filling and grading are to be performed, and not proceed with the WORK until unsatisfactory conditions have been corrected.

CONTRACTOR shall examine existing grade prior to commencement of WORK and report to UTILITY if elevations of existing grade vary from elevations shown on DRAWINGS.

9.12.2 Quality Assurance: All work shall be performed in compliance with applicable requirements of governing authorities having jurisdiction.

The CONTRACTOR, at his expense, shall engage soil testing and inspection services for quality control testing during earthwork operations. The testing and inspection service shall be subject to the approval of UTILITY.

Quality control testing shall be performed during construction to ensure compliance with these SPECIFICATIONS. CONTRACTOR shall allow the testing service to inspect and approve fill materials and fill layers before further construction is performed. The CONTRACTOR shall give copies of all test results in a report form to UTILITY to demonstrate compliance with compaction requirements stipulated in this MANUAL.

## Division 3

### Section 10

#### Boring and Jacking

##### 10.1 General

The installation of a casing pipe by the method of boring and jacking shall be covered by these SPECIFICATIONS. The overall work scope shall include, but not be limited to, boring and jacking pits and equipment, sheeting, steel casing pipe, spacers, coatings, location signs as required, miscellaneous appurtenances to complete the entire WORK as shown on the STANDARD DETAILS, and restoration. Applicable provisions of Division 3 shall apply concurrently with these SPECIFICATIONS. Boring and jacking operations shall be performed within the right-of-way and/or easements shown on the DRAWINGS.

##### 10.2 Pipe Material

10.2.1 Steel Casing: Steel casings shall conform to the requirements of ASTM Designation A 139 (straight seam pipe only) Grade "B" with minimum yield strength of 35,000 psi. The casing pipes shall have the minimum nominal diameter and wall thickness as shown on the following table:

Carrier Pipe Nominal Diameter	Casing Outside Diameter	Casing Wall Thickness (Hwy)	Casing Wall Thickness (RR)
4"	14"	.250"	.250"
6"	16"	.250"	.250"
8"	18"	.250"	.312"
10"	22"	.250"	.375"
12"	24"	.250"	.375"
14", 16"	30"	.312"	.500"
18", 20"	36"	.375"	.563"
24"	48"	.500"	.625"
The inside diameter of the casing pipe shall be a minimum of 3 inches greater than the outside diameter of the carrier pipe bell or coupling.			

Field and shop welds of the casing pipes shall conform to the American Welding Society (AWS) standard specifications. Field welds shall be complete penetration, single-bevel groove type joints. Welds shall be airtight and continuous over the entire circumference



of the pipe and shall not increase the outside pipe diameter by more than 3/4 inch.

Casings shall extend a minimum of 5 feet beyond paved areas.

10.2.2 Carrier Pipe: The carrier pipe shall be minimum class 50 ductile iron pipes with restrained joints. Ductile iron pipe shall comply with the specification outlined in Division 3, Section 1 of these SPECIFICATIONS.

10.2.3 Inspection: All casing pipe to be installed may be inspected at the site of manufacture for compliance with these SPECIFICATIONS by an independent laboratory selected and paid for by UTILITY. The manufacturer's cooperation shall be required in these inspections.

All casing pipe shall be subjected to a careful inspection prior to being installed. If the pipe fails to meet the specifications, it shall be removed and replaced with a satisfactory replacement at no additional expense to UTILITY.

### 10.3 Pipe Handling

Care shall be taken in loading, transporting, and unloading to prevent injury to the pipe or coatings. Pipe shall not be dropped. All pipes shall be examined before installation, and no piece shall be installed which is found to be defective. Any damage to the pipe or coatings shall be repaired to the satisfaction of UTILITY.

### 10.4 Construction Requirements

10.4.1 Work Coordination: It shall be the contractor's responsibility to perform the boring and jacking work in strict conformance with the requirements of the agency in whose right-of-way or easement the work is being performed. Any special requirements of the agency such as insurance, flagmen, etc., shall be strictly adhered to during the performance of WORK. The special requirements shall be performed by the CONTRACTOR at no additional cost to UTILITY.

10.4.2 Dewatering: Dewatering through the casing during construction shall not be permitted. All dewatering methods shall be approved by UTILITY before construction work begins.

10.4.3 Carrier Pipe Support: The carrier pipes shall be supported within the casing pipes so that the pipe bells do not rest directly on the casing. The load of the carrier pipes shall be distributed along the casing by casing spacers. Casing spacers shall be bolt on style split shell metal spiders with bituminous coating or approved equal. All nuts and bolts shall be stainless steel. Runners shall be made of a high molecular weight polymer with inherent high abrasion resistance and a low coefficient of friction.

10.4.4 Jacking Pits: Excavation adjacent to the roads shall be performed in a manner to adequately support the roads. Bracing, shoring, sheeting or other supports shall be installed as needed. CONTRACTOR shall install suitable reaction blocks for the jacks as required. Jacking operations shall be continuous and precautions shall be taken to avoid interruptions which might cause the casing to "freeze" in place. Upon completion of jacking operations, the reaction blocks, braces, and all other associated construction materials shall be completely removed from the site.

- 10.4.5 MISCELLANEOUS REQUIREMENTS: Correct line and grade shall be carefully maintained. Earth within the casing shall not be removed too close to the cutting edge in order to prevent the formation of voids outside the casing. If voids are formed, they shall be satisfactorily filled with grout by pumping.

The sections of steel casing shall be field welded in accordance with the applicable portions of AWWA C206 and AWS D7.0 for field welded pipe joints. CONTRACTOR shall wire brush the welded joints and paint with Inertol Quick-Drying Primer 626 by Koppers Company or approved equal. After completion of jacking, CONTRACTOR shall clean the interior of the casing of all excess material.

The annular space between the carrier pipe and casing shall be filled with clean sand, if required in the Bore and Jack permit. Masonry plugs shall be installed at each open end of the casing. Plugs shall be 12" thick and suitable for restraining the earth load while allowing drainage of the casing.

## Division 3

### Section 11

#### Pressure Pipe Restraint

##### 11.1 General

Pressure pipe fittings and other items requiring restraint shall be braced with restraining assemblies as specified in this Section.

##### 11.2 Restrained Joint Construction

Sections of piping requiring restrained joints shall be constructed using pipe and fittings with restrained "Locked-type" joints manufactured by the pipe and fitting manufacturer and the joints shall be capable of holding against withdrawal for line pressures of a minimum 150 psi. Mechanical joint ductile iron pipe retainer glands shall not be permitted. Any restrained joints that allow for elongation upon pressurization will not be allowed in those locations where the pipe comes out of the ground.

Restrained pipe joints that achieve restraint by incorporating cut out sections in the wall of the pipe shall have a minimum wall thickness at the point of cut out that corresponds with the minimum specified wall thickness for the remainder of the pipe.

The minimum number of restrained joints required for resisting forces at fittings and changes in direction of pipe shall be determined from the length of restrained pipe on each side of fittings and changes in direction necessary to develop adequate resisting friction with the soil.

The required lengths of restrained joint ductile iron pipe and PVC pipe shall be determined by the ENGINEER and shown in a tabular form as depicted on the "Restrained Joint Detail" in the STANDARD DETAILS.

Wherever 2-45° bends are used in place of a 90° bend and the minimum length of restrained pipe required from one 45° bend extends beyond the other 45° bend, the 2-45° bends will be considered as though a 90° bend were located midway between the 2-45° bends. No use of 90 degree bends is allowed unless approved by the UTILITY in writing.

##### 11.3 Mechanical Restraining Devices

11.3.1 General: Mechanical Restraining Devices as specified herein may be substituted for the restrained "Locked-Type" joints. The length of pipe to be restrained shall be based on the "Restrained Joint Detail" in the STANDARD DETAILS.

11.3.2 Joint Restraint Device: Mechanical joint restraint shall be incorporated in the design of the follower gland and shall include a restraining mechanism which, when actuated, imparts multiple wedging action against the pipe, increasing its resistance as the pressure

increases. Flexibility of the joint shall be maintained after burial. Glands shall be manufactured of ductile iron conforming to ASTM A536. Restraining devices shall be of ductile iron heat treated to a minimum hardness of 370 BHN. Dimensions of the gland shall be such that it can be used with the standardized mechanical joint bell and tee-head bolts conforming to ANSI A11.11 and ANSI/AWWA C153/A21.53. Twist-off nuts shall be used to insure proper actuating of the restraining devices.

The mechanical joint restraint device shall have a working pressure of at least 150 psi with a minimum safety factor of 2:1 (this will be shown on the PLANS).

## Division 3

### Section 12

#### Connections to Pressure Mains

##### 12.1 General

Installations of pressure connections 2" and larger shall be made in accordance with this Section.

##### 12.2 Tapping Sleeves

12.2.1 General: Tapping sleeves shall be mechanical joint sleeves or fabricated steel sleeves as specified below. Tapping Sleeves shall meet AWWA C233 (latest version). All pressure connections to asbestos cement pipe and all "size on size" taps shall utilize mechanical joint sleeves.

12.2.2 Mechanical Joint Sleeves: Sleeves shall be cast of gray-iron or ductile-iron and have an outlet flange with the dimensions of the Class 125 flanges shown in ANSI B16.1, properly recessed for tapping valve. Glands shall be gray-iron or ductile iron. Gaskets shall be vulcanized natural or synthetic rubber. Bolts and nuts shall comply with ANSI/AWWA C111/A21.11. Sleeves shall be capable of withstanding a 200-psi working pressure.

12.2.3 Steel Tapping Sleeves: Sleeves shall be fabricated of minimum 3/8" carbon steel meeting ASTM A285 Grade C. Outlet flange shall meet AWWA C-207, Class "D" ANSI 150 lb. drilling and be properly recessed for the tapping valve. Bolts and nuts shall be high strength low alloy steel to AWWA C111 (ANSI A21.11). Gasket shall be vulcanized natural or synthetic rubber. Sleeve shall have manufacturer-applied fusion bonded epoxy coating, minimum 12 mil thickness.

12.2.4 Tapping Valves: Tapping valves shall meet the requirements of Section 22.2 except that units shall be flange by mechanical joint ends. Valves shall be compatible with tapping sleeves as specified above and specifically designed for pressure connection operations.

##### 12.3 NOTIFICATION AND CONNECTION TO EXISTING MAINS

TO AVOID THE POSSIBILITY OF ISOLATION VALVES BEING LEFT OPEN - All connections to existing mains shall be made by the CONTRACTOR only after the connection procedure and his work scheduling has been reviewed and approved by UTILITY. All connections to existing piping will be such that the connection is made through a wet tap with tapping valve or the connection is started with a gate valve. This is to ensure that the existing system's cleanliness and sanitation is maintained until the new piping system has satisfactorily passed all test and has been disinfected The CONTRACTOR shall submit a written request to UTILITY a minimum of one (1) week prior to scheduling said connections. In his request he shall outline the following:

1. Points of connection, fittings to be used, and method of flushing and disinfection if applicable.
2. Estimated construction time for said connections.

UTILITY shall review the submittal within one (1) week after receiving it and inform the CONTRACTOR regarding approval or denial of his request. If his request is rejected by UTILITY, the CONTRACTOR shall resubmit his request modifying it in a manner acceptable to UTILITY.

All connections shall only be made on the agreed upon date and time. If the CONTRACTOR does not initiate and complete the connection work in the agreed upon manner, he shall be required to reschedule the said connection by following the procedure outlined above.

The CONTRACTOR shall not operate any valves in the system.

## **12.4 Installation**

12.4.1 Excavation, Backfill, Compaction and Grading: The applicable provisions of Division 3, Section 9 shall apply.

12.4.2 Construction Details: Sufficient length of main shall be exposed to allow for installation of the tapping sleeve and valve and the operation of the tapping machinery. The main shall be supported on concrete pedestals or bedding rock at sufficient intervals to properly carry its own weight, plus the weight of the tapping sleeve valve and machinery. Any damage to the main due to improper or insufficient supports shall be repaired at the contractor's expense.

The inside of the tapping sleeve and valve, the outside of the main, and the tapping machine shall be cleaned and swabbed or sprayed with 10% liquid chlorine prior to beginning installation for water system pressure connections.

After the tapping sleeve has been mounted on the main, the tapping valve shall be bolted to the outlet flange, making a pressure tight connection. Prior to beginning the tapping operation, the sleeve and valve shall be pressure tested at 150 psi to ensure that no leakage will occur.

For pressure connections 12" diameter or less, the minimum diameter cut shall be 1/2" less than the nominal diameter of the pipe to be attached. For 14" through 20" installations, the minimum diameter shall be 1 1/2" less; for larger taps, the allowable minimum diameter shall be 2" to 3" less than the nominal diameter of the pipe being attached. After the tapping procedure is complete, the CONTRACTOR shall submit the coupon to UTILITY.

Adequate restrained joint fittings shall be provided to prevent movement of the installation when test pressure is applied. Provisions of Division 3, Section 11 shall apply.



## Division 3

### Section 13

#### Pipe Material for Water Mains and Service Connections

##### 13.1 General

These SPECIFICATIONS cover the pipe, fittings, and accessory items used for water distribution systems.

Pipe used in water distribution systems shall be either polyvinyl chloride (PVC), or ductile iron pipe (DIP).

The CONTRACTOR shall be responsible for all materials furnished and storage of same, until the date of substantial completion. He shall replace at his expense all materials found to be defective or damaged in handling or storage. The CONTRACTOR shall, if requested by UTILITY, furnish certificates, affidavits of compliance, test reports, or samples for check analysis for any of the materials specified herein. All pipe delivered to project site for installation is subject to random testing for compliance with the designated specifications.

All water main materials, including pipe and fittings, shall meet NSF/ANSI 61 standards per rule .0406 of the Rules Governing Water Systems.

##### 13.2 PVC Pipe

13.2.1 PVC Pipe: All PVC pipe of nominal diameter three (3) through twelve (12) inches shall be manufactured in accordance with AWWA Standard C900, latest edition. The PVC pipe shall have a minimum working pressure rating of 200 psi and shall have a dimension ratio (DR) of 14. Pipe shall be the same O.D. as ductile iron pipe. PVC pipe smaller than three (3) inches shall be SDR 21 Class 200.

13.2.2 Joints: PVC pipe shall have integral bell push-on type joints conforming to ASTM D3139.

13.2.2 Fittings: Fittings used with C900 PVC pipe shall be mechanical joint ductile iron or gray iron conforming to ANSI/AWWA A21.10/C110, 250 psi minimum pressure rating, or ductile iron compact fittings four (4) through twenty-four (24) inches in accordance with ANSI/AWWA A21.53/C153.

Fittings used with 3" and smaller PVC pipe shall be manufactured from virgin rigid PVC (polyvinyl chloride) compounds with a Cell Class of 12454 as identified in ASTM D 1784. All fitting shall be threaded unions Bell and spigot with elastomer gaskets, or compression type – no glue joints are to be used.

##### 13.3 Ductile Iron Pipe & Fittings



- 13.3.1 **Ductile Iron Pipe:** All ductile iron pipe of nominal diameter (3) through fifty-four (54) inches shall conform to ANSI/AWWA A21.50/C150 and ANSI/AWWA A21.51/C151. A minimum of Class 50 pipe shall be supplied for all sizes of pipe unless specifically called out in the DRAWINGS, or required by UTILITY.
- 13.3.2 **Fittings:** Any fittings required shall be mechanical joint ductile iron or gray iron conforming to ANSI/AWWA A21.10/C110, 250 psi minimum pressure rating, or ductile iron compact fittings three (3) through twenty-four (24) inches in accordance with ANSI/AWWA A21.53/C153.
- 13.3.3 **Joints:** Joints for ductile iron pipe and fitting joints shall be push-on or mechanical joints conforming to ANSI/AWWA A21.11/C111. Where called for in the plans, restrained or flanged joints shall be provided. Flanged joints shall conform to ANSI Standard B 16.1-125 LB. Restrained joints shall conform to Division 3, Section 1, 11.3.
- 13.3.4 **Polyethylene Encasement:** The pipe shall be polyethylene encased (8 mil) where shown on the DRAWINGS or required by UTILITY in accordance with ANSI/AWWA A21.51/C105.

#### **13.4 Service Pipe, Stops, Fittings, and Service Saddles**

- 13.4.1 **Service Pipe:** All service lines shall be 3/4", 1", 1-1/2" or 2" blue polyethylene tubing conforming to specifications in AWWA C800 and AWWA C901. One and one-half inch (1-1/2") and larger shall be sized in accordance with the Iron Pipe Sizing Standard (IPS); 3/4 " and 1" shall be the Copper Tube Sizing Standard (CTS)
- 13.4.2 **Stops:** Corporation stops shall be 3/4", 1", 1-1/2" or 2" brass, equipped with connections compatible with the polyethylene tubing and threaded in accordance with specifications in AWWA C800 and AWWA C901. Curb stops shall be sized to match the meter size and conform to the specifications in AWWA C800 and AWWA C901. There will be one corporation stop at the main tap and start of the service line. There will be a second corporation stop type of ball valve placed at the end of the service line and prior to the meter yoke so that the meter yoke can be isolated. The second ball corporate stop shall be accessible from inside of the meter box.
- 13.4.3 **Fittings:** Fittings shall be brass, cast and machined in accordance with specifications in AWWA C800 and AWWA C901, with compatible polyethylene tubing connections.
- 13.4.4 **Service Saddles:** A service saddle shall be used for all service line taps. Service saddles shall be double strap, anchored by a minimum four (4) bolt pattern on a ductile iron saddle body. Service saddles for PVC pipe shall have the double strap sized exactly to the pipe outside diameter. Sealing gaskets shall be BUNA-N rubber and straps shall be corrosion resistant alloy steel.

UTILITY may require a stainless-steel strap and fusion epoxy or nylon coated ductile iron body with stainless steel hardware in areas designated as corrosive.

- 13.4.5 All services shall be sleeved with 2" schedule 40 PVC or greater under paved areas.

## Division 3

### Section 14

#### Water Main Installation, Disinfection and Pressure Testing

##### 14.1 General

Pipe shall be installed in accordance with the manufacturer's specifications and instructions for the type of pipe used and applicable AWWA standards, such as C600 and C605, unless otherwise stated in these SPECIFICATIONS.

##### 14.2 Pipe Handling

All types of pipe shall be handled in such manner as will prevent damage to the pipe or coating. Accidental damage to pipe or coating shall be repaired to the satisfaction of UTILITY or be removed from the job. When not being handled, the pipe shall be supported on timber cradles or on properly prepared ground, graded to eliminate all rock points and to provide uniform support along the full length. When being transported, the pipe shall be supported at all times in a manner which will not permit distortion or damage to the lining or coating. Any unit of pipe that, in the opinion of UTILITY, is damaged beyond repair by the CONTRACTOR shall be removed from the site of the work and replaced with another unit.

Joint gaskets shall be stored in clean, dark, dry location until immediately before use.

Dirt or other foreign material shall be prevented from entering the pipe or pipe joint during handling or laying operations and any pipe or fitting that has been installed with dirt or foreign material in it shall be removed, cleaned and reinstalled. At times when pipe installation is not in progress, the open ends of the pipe shall be closed by a watertight plug or by other means approved by UTILITY to ensure absolute cleanliness inside the pipe.

##### 14.3 Separation of Water Mains and Sewers

14.3.1 General: Water mains that are installed in the vicinity of pipe lines designated to carry raw wastewater or reclaimed water (wastewater effluent) shall meet the horizontal and vertical separations specified below.

14.3.2 Horizontal Separation: A minimum horizontal separation of ten feet, outside of pipe to outside of pipe, shall be maintained between potable water piping and domestic wastewater gravity piping or storm water piping.

A minimum horizontal separation of ten feet, outside of pipe to outside of pipe, shall be maintained between potable water piping and reclaimed water piping carrying unrestricted public access reuse water.

Where it is not possible to maintain the required horizontal separation, the potable water

main may be laid in a separate trench or on an undisturbed earth shelf located on one side of the wastewater gravity piping, storm water piping or reclaimed water piping and at such an elevation that the bottom of the water main is at least eighteen inches above the top of the other pipe.

If the minimum allowable ten feet of horizontal separation or eighteen inches vertical separation in a separate trench cannot be maintained, the water pipe shall be ductile iron if the other pipe is a storm water pipe that may not be possibly upgraded in material and joint type.

If the minimum allowable ten feet of horizontal separation or eighteen inches vertical separation in a separate trench cannot be maintained, the water pipe and sanitary sewer pipe shall be ductile iron.

If the other pipe is a reclaimed water pipe and the above separation requirements are not met, the reclaimed water pipe shall be ductile iron.

Deviations from these requirements and other alternatives may be considered on a case-by-case basis if supported by data from the design engineer and must receive specific approval by the Department prior to implementation.

There shall be at least a 10-foot horizontal separation between potable water piping and sanitary sewer force mains without exception. Field conditions not allowing the minimum separation being achieved shall be reported to the engineer. Specific solutions to separation problems as proposed by the engineer must be accepted by the Department prior to implementation.

No water main shall pass through or come in contact with any part of a sanitary sewer manhole or storm sewer structure.

- 14.3.3 Vertical Separation: A minimum vertical separation of eighteen inches, outside of pipe to outside of pipe, shall be maintained between potable water piping, wastewater gravity piping, storm water piping or reclaimed water piping.

When there is less than eighteen inches of net vertical clearance between the potable water pipe and storm water pipe, the water piping shall be ductile iron. One full length of pipe shall be centered at the point of crossing.

If the minimum allowable ten feet of horizontal separation or eighteen inches vertical separation in a separate trench cannot be maintained, the water pipe and sanitary sewer pipe shall be ductile iron.

If the other pipe is a reclaimed water pipe and the above vertical separation requirements are not met, the reclaimed water pipe shall be ductile iron.

Special structural support or concrete saddles may be necessary at the pipe crossing location.

It is preferable to install the potable water pipe above the domestic wastewater, storm water or reclaimed water pipe at crossings.

Deviations from the separation requirements and other alternatives may be considered on a case-by-case basis if supported by data from the design engineer and must receive specific approval from the UTILITY and PWS prior to implementation.

There shall be a minimum of eighteen inches of net vertical separation between water mains and sanitary sewer force mains without exception. Situations where it is not possible to maintain the required vertical separation shall be reported to the engineer. Specific solutions as proposed by the engineer must be accepted by the UTILITY and PWS prior to implementation.

14.3.4 Crossing a Water Main over a Sewer: Whenever it is necessary for a water main to cross over a sewer, the water main shall be laid at such an elevation that the bottom of the water main is at least eighteen inches above the top of the sewer, unless local conditions or barriers prevent an eighteen inch vertical separation – in which case both the water main and sewer shall be constructed of ferrous materials and with joints that are equivalent to water main standards for a distance of ten feet on each side of crossing.

14.3.5 Crossing a Water Main under a Sewer: Whenever it is necessary for a water main to cross under a sewer, both the water main and the sewer shall be constructed of ferrous materials and with joints equivalent to water main standards for a distance of ten feet on each side of the point of crossing. A section of water main pipe shall be centered at the point of crossing.

#### **14.4 Trench Preparation and Pipe Bending**

14.4.1 Trench Preparation and Pipe Bedding: Applicable provisions of Division 3, Section 9 shall apply. Also refer to STANDARD DETAILS.

14.4.2 Pipe Preparation and Handling: All pipe and fittings shall be inspected prior to lowering into trench to insure no cracked, broken, or otherwise defective materials are being used. CONTRACTOR shall clean ends of pipe thoroughly and remove foreign matter and dirt from inside of pipe and keep clean during and after installation.

CONTRACTOR shall use proper implements, tools, and facilities for the safe and proper protection of the WORK. CONTRACTOR shall lower pipe into the trench in such a manner as to avoid any physical damage to the pipe and shall remove all damaged pipe from the job site. Care shall be taken not to drop or dump pipe into trenches under any circumstances.

14.4.3 Trench Dewatering and Drainage Control: Specifications from Division 3, Section 9 shall apply. CONTRACTOR shall prevent water from entering the trench during excavation and pipe installation operations to the extent required to properly grade the bottom of the trench and allow for proper compaction of the backfill. Pipe shall not be installed in water.

14.4.4 Survey Line and Grade: Pipe shall be installed to the lines and grades shown on the PLANS. The CONTRACTOR shall provide line and grade stakes at a 1,000-foot maximum spacing and at all line and/or grade change locations. CONTRACTOR shall provide Temporary Bench Marks at maximum 1,000-foot intervals. The minimum pipe depth shall be three (3) feet below the finished grade surface or three (3) feet below the elevation of the edge of the pavement of the road surface whichever is greater.

14.4.5 Pipe-laying in Trench: CONTRACTOR shall prevent foreign material from entering the pipe while it is being placed in the trench. CONTRACTOR shall remove all foreign material from the pipe or joint ring before the next pipe is placed. If the pipe-laying crew cannot put the pipe into the trench, and in place, without getting soil into the pipe, UTILITY may require that snugly-fitted, tightly-woven canvas bags be placed over each end before lowering the pipe. The bags shall be left in place until the connection is to be made to the adjacent pipe. During laying operations, CONTRACTOR shall keep debris, tools, clothing, or other materials out of the pipe.

14.4.6 Installing PVC Pipe: All PVC pipe shall be installed in accordance with standards set forth in the UNI-BELL "Handbook of PVC Pipe Design and Construction" unless such standards conflict with this MANUAL in which case this MANUAL shall apply.

14.4.7 Installing Ductile Iron Pipe: All ductile-iron pipe shall be installed in accordance with AWWA C600 unless such standards conflicts with this MANUAL in which case this MANUAL shall apply. CONTRACTOR shall cut pipe only as necessary to comply with alignment shown on the PLANS. Flame cutting of pipe shall not be allowed.

CONTRACTOR shall provide special tools and devices, such as special jacks, chokers, and similar items required for proper installation. Lubricant for the pipe gaskets shall be furnished by the pipe manufacturer, and no substitutes shall be permitted under any circumstances.

The pipe shall be polyethylene encased (8 mil) where shown on the DRAWINGS in accordance with ANSI/AWWA A21.51/C105.

14.4.8 Installing Pipes on Curves: Long radius curves, either horizontal or vertical, may be installed with standard pipe by deflections at the joints. Maximum deflections at pipe joints and laying radius for the various pipe lengths shall be as recommended by the pipe manufacturer.

14.4.9 Pipe Restraining: Requirements specified in Division 3, Section 11 shall apply.

14.4.10 Bedding and Backfill for Pipes: Requirements specified in Division 3, Section 9 shall apply.

## 14.5 Hydrostatic Tests

14.5.1 General: Hydrostatic tests shall consist of pressure test and leakage test. Hydrostatic tests shall be conducted on all newly installed pressure pipes, joints and valves including all service lines to the curb stops. Air testing of pressure pipes will not be permitted under any circumstance. Tests may be made on sections not exceeding 2,000 feet, when this procedure is acceptable to UTILITY. CONTRACTOR shall furnish all necessary equipment and material, make all taps, and furnish all closure pieces in the pipe as required. Equipment to be furnished by the CONTRACTOR shall include graduated containers, pressure gauges, hydraulic force pumps, and suitable hoses and piping. UTILITY will monitor and approve a satisfactory test.

When filling and/or flushing a new water line extension that is connected to an existing system, the valve between the two shall always stay closed. Filling and/or flushing shall

be accomplished through and adequately sized “jumper”. The jumper shall consist of a tap onto the existing water line, a valve, a Reduced Pressure Zone (RPZ) backflow preventer, a valve, and a tap into the new extension. Filling and flushing of the new water line shall be accomplished through this tap. At no time shall the RPZ be removed until written authorization has been received from the UTILITY. The operation of the valves shall be coordinated with the UTILITY.

ONCE THE NEW WATER LINE EXTENSION IS ACCEPTED BY THE UTILITY, ALL TEMPORARY TAPS, PIPING AND RPZs SHALL BE REMOVED 9TAPS CAN BE ABANDONED IN PLACE.

The CONTRACTOR may conduct hydrostatic tests after the trench has been partially backfilled with the joints left exposed for inspection for his informational purposes only. The hydrostatic tests for acceptance shall only be conducted after the trenches have been completely backfilled and compacted as specified. Where any section of pipe is provided with concrete thrust blocking, pressure test will not be made until at least five days have elapsed after the thrust blocking is installed.

The CONTRACTOR is to provide UTILITY 48 hour notice before any pressure testing is to begin.

- 14.5.2 Testing Criteria: All pipe sections to be pressure tested shall be subjected to a hydrostatic pressure of 150 psi. The duration of each pressure test shall be for a period of 2 hours. If during the test, the integrity of the tested line is in question, UTILITY may require a 6-hour pressure test. The basic provisions of AWWA C-600 and C-605/M23 shall be applicable.
- 14.5.3 Procedure for Pressure Test: Each section of pipe to be tested, as determined by UTILITY, shall be slowly filled with water and the specified test pressure shall be applied by means of a pump connected to the pipe in a satisfactory manner. Before applying the specified test pressure, all air shall be expelled from the pipe. To accomplish this, taps shall be made, and appropriate valves installed to ensure bleeding of all air from the main. If defective pipes, fittings, valves, or hydrants are discovered in consequence of this pressure test, all such items shall be removed and replaced by the CONTRACTOR with sound material and the test shall be repeated until satisfactory results are obtained. Provisions of AWWA C600 and C605/M23, where applicable, shall apply.
- 14.5.4 Procedure for Leakage Test: After completion of the pressure test, a leakage test shall be conducted to determine the quantity of water lost by leakage under the specified test pressure. Applicable provisions of AWWA C600 and C605/M23 shall apply.

Allowable leakage in gallons per hour for pipeline shall not be greater than that determined by the formula:

$$L = \frac{SD(P)^{1/2}}{148,000}$$

L = Allowable leakage in gallons per hour.

S = Length of pipe tested, in feet.

D = Nominal diameter of the pipe in inches.

P = Average test pressure during leakage test in pounds per square inch gauge.

Leakage is defined as the quantity of water to be supplied in the newly installed pipe or any valve section under test which is necessary to maintain the specified leakage test pressure after the pipe has been filled with water and the air expelled. Should any test of pipe installed disclose leakage greater than that allowed, CONTRACTOR shall locate and replace or repair the defective joints, pipe or valve until the leakage from subsequent testing is within the specified allowance.

**In accordance with Division 1 Section 2, the engineer of record shall submit a certifying statement/report on the results of the testing with the Final Certification Package.**

## 14.6 Disinfection of Water Mains

14.6.1 General: Before being placed in service, all new water mains shall be chlorinated in accordance with the specifications below and the procedures outlined in AWWA C651 "Standard Procedure for Disinfecting Water Mains." , section 4.4.3, the Continuous Feed Method, and section .1003 of *The Rules Governing Public Water Supply Systems*.

14.6.2 Flushing: Sections of pipe to be disinfected shall first be directionally flushed (full diameter) to remove any solids or contaminated material that may have become lodged in the pipe. If no hydrant is installed at the end of the main, then a blow-off valve shall be provided large enough to develop a velocity of at least 2.5 feet per second in the main.

A Disinfection plan must be presented to the UTILITY prior to disinfection/flushing. If additional valves and/or blow-offs/hydrants are required to achieve a directional flushing, they will be provided by the Contractor as part of the construction.

All taps required for chlorination or flushing purpose or for temporary or permanent release of air shall be provided for by the CONTRACTOR as a part of the construction of water mains. After the disinfection, all such taps shall be sealed to the satisfaction of UTILITY.

14.6.3 Disinfection Criteria: Before being placed into service, all new mains and repaired portions of, or extensions to existing mains shall be chlorinated so that the initial chlorine residual is not less than 50 mg/l.

14.6.4 Form of Applied Chlorine: Chlorine may be applied as liquid chlorine (gas-water mixture), or a mixture of water and high-test calcium hypochlorite. CONTRACTOR shall assume responsibility for safe handling of chlorine and shall meet requirements of OSHA and other regulatory agencies for safe handling of chlorine.

14.6.5 Point of Application: The preferred point of application of the chlorinating agent is at the beginning of the pipe line extension or any valved section of it, and through a corporation stop inserted in the pipe. The water injector for delivering the chlorine-bearing water into the pipe should be supplied from a tap made on the pressure side of the gate valve controlling the flow into the pipe line extension. Alternate points of applications may be used when approved or directed by UTILITY.

14.6.6 Operation of Aqua North Carolina Valves: Valves shall be manipulated by UTILITY personnel so that the strong chlorine solution in the line being treated will not flow back

into the line supplying the water.

- 14.6.7 Retention Period: Treated water shall be retained in the pipe at least 24 hours.
- 14.6.8 Chlorinating Valves and Hydrants: In the process of chlorinating newly installed pipe, all valves or other appurtenances shall be operated while the pipe line is filled with the chlorinating agent and under normal operating pressure.
- 14.6.9 Final Flushing and Testing: Following chlorination, all treated water shall be thoroughly flushed from the newly installed pipe at its extremity until the replacement water throughout its lengths shows upon test, a free chlorine residual not in excess of 1 ppm after flushing.

After flushing; water samples, as directed by UTILITY, shall show acceptable bacteriological results. All bacteriological testing shall be performed by a private laboratory. All such bacteriological analysis must be performed by a laboratory certified by the State of North Carolina.

Proper chain of custody procedures must be followed and samples shall only be collected by certified laboratory personnel in the presence of UTILITY'S personnel.

**Copies of testing results and all related correspondence with the NCDENR shall be submitted to UTILITY.**

- 14.6.10 Repetition of Flushing and Testing: Should the initial treatment result in an unsatisfactory bacterial test, the original chlorination procedure shall be repeated by the CONTRACTOR until satisfactory results are obtained. The water lines shall not be placed into service until bacteriological test results are found to be satisfactory by a state-approved laboratory.

#### **14.7 Notification and Connection to Existing Mains**

Requirements specified in Division 3, Section 12.3 shall apply.

#### **14.8 Cross-Connection Control**

- 14.8.1 Inspection and Testing: Backflow prevention assemblies shall be tested by a certified cross-connection control technician in the presence of a UTILITY representative.

All backflow prevention assemblies shall be inspected and approved by UTILITY prior to project acceptance and service being provided.

#### **14.9 Water Service Piping and Connection**

Water service piping and connection shall be installed as indicated in the STANDARD DETAILS. The location of all service lines shall be as shown on the DRAWINGS and shall be either single or dual service. On curbed streets, the exact location for each installed service shall be marked by etching or cutting a "W" in the concrete curb. Where no curb exists, locations shall be adequately marked by a method approved by UTILITY.

#### **14.10 Location and Identification**



All PVC water mains shall be a solid blue color. All water mains shall have an "Early Warning" protection tape installed continuously along the alignment. The protection tape shall be installed during backfilling 8 to 12 inches below finished grade directly over the pipe and be continuously marked "Caution, Water Main Buried Below." The tape shall have a metallic detectable strip included and be blue in color. All protection tape shall be as Terra-Tape or equal. See STANDARD DETAILS. In addition to the warning tape there shall be installed a 12 gage THNN location wire. Concurrent Ends of this location wire shall be physically connected utilizing a protective corrosion resistant connector as approved by the UTILITY.

All ductile iron water mains shall either be marked with a continuous 2-inch wide blue stripe located within the top 90 degrees of the pipe or wrapped in blue polyethylene bags. Backfill shall not be placed for 30 minutes following paint application.

## Division 3

### Section 15

#### Valves, Hydrants & Accessories

##### 15.1 General

All valves and appurtenances shall be products of well established firms who are fully experienced and qualified in the manufacture of the particular equipment to be furnished. The equipment shall be designed, constructed and installed in accordance with the best practices and methods and shall comply with these SPECIFICATIONS as applicable.

##### 15.2 Resilient Seat Gate Valves

15.2.1 General: All gate valves twenty-four (24) inches and smaller shall be resilient seat gate valves. All Valves with be clock-wise closed and counter clock-wise open Such valves shall be resilient seated, manufactured to meet or exceed the requirements of AWWA C509, latest revision, and in accordance with the following SPECIFICATIONS. Valves shall have an unobstructed waterway equal to or greater than the full nominal diameter of the pipe

15.2.2 Material: The valve body, bonnet, and bonnet cover shall be cast iron ASTM A126, Class B. All ferrous surfaces inside and outside shall have a fusion-bonded epoxy coating. A 2" wrench nut shall be provided for operating the valve in a buried installation. All valves shall be tested in strict accordance with AWWA C509. All valves are to open counterclockwise.

15.2.3 Miscellaneous Requirements: The valves shall be right hand open, non-rising stem with the stem made of cast, forged, or rolled bronze as specified in AWWA C509. Two stem seals shall be provided and shall be of the o-ring type. The stem nut must be independent of the gate.

The resilient sealing mechanism shall provide zero leakage at the water working pressure when installed with the line flow in either direction.

##### 15.3 Butterfly Valves

15.3.1 General: All shut-off valves sixteen (16) inches and larger shall be butterfly valves. Butterfly valves and operators shall conform to the AWWA Standard Specifications for Rubber Seated Butterfly Valves, Designation C504, except as hereinafter specified. Valves, except as specified hereinafter, shall be Class 150A or B. All Valves with be clock-wise closed and counter clock-wise open

15.3.2 Material: The valve body shall be constructed of close grain cast iron per ASTM A126, Class B or equivalent material. All retaining segments and adjusting devices shall be of

corrosion resistant material. Valve seats shall be a natural rubber or synthetic rubber compound. Valve seats 30 inches and larger shall be field adjustable and replaceable without dismounting operator disc or shaft and without removing the valve from the line. All retaining segments and adjusting devices shall be of corrosion resistant material. Valves 24 inches and smaller shall have bonded or mechanically restrained seats as outlined in AWWA C504.

15.3.3 Face-to-Face Dimension: The face-to-face dimensions of valves shall be in accordance with above mentioned AWWA Specification for short-body valve.

15.3.4 Valve Shaft: The valve shaft shall be turned, ground, polished and constructed of 18-8 stainless steel and designed for both torsional and shearing stresses when the valve is operated under its greatest dynamic or seating torque. Shaft shall be of either a one-piece unit extending full size through the valve disc and valve bearing or it may be of a stub shaft design.

15.3.5 Valve Operator: In general, the butterfly valve operators shall conform to the requirements of AWWA Standard Specifications for Rubber Seated Butterfly Valves, Designation C504, insofar as applicable

## 15.4 Valve Installation

All valves shall be inspected upon delivery in the field to insure proper working order before installation. They shall be set and jointed to the pipe in the manner as set forth in the AWWA Standards for the type of connection ends furnished. All valves and appurtenances shall be installed true to alignment and rigidly supported. Any damage to the above items shall be repaired to the satisfaction of UTILITY before they are installed.

Valves shall be installed in a vertical position and be provided with a standard valve box so arranged that no shock will be transmitted to the valve. The box shall be vertically centered over the operating nut, and the cast iron box cover shall be set flush with the road bed or finished surface.

After installation, all valves shall be subjected to the field test for piping as outlined in Division 3, Section 14 of these SPECIFICATIONS. Should any defects in materials or workmanship appear during these tests, the CONTRACTOR shall correct such defects to the satisfaction of UTILITY.

Flanged joints shall be made with hot dipped galvanized bolts, nuts and washers. Mechanical joints shall be made with mild corrosion resistant alloy steel bolts and nuts. All exposed bolts shall be painted the same color as the pipe. All buried bolts and nuts shall be heavily coated with two (2) coats of bituminous paint

## 15.5 Valve Boxes

All buried valves shall have cast-iron three-piece valve boxes Valve boxes shall be provided with suitable heavy bonnets and shall extend to such elevation at the finished grade surface as directed by UTILITY. The barrel shall be two-piece, sliding type, having 5-1/4 inch shaft. The upper section shall have a flange at the bottom having sufficient bearing area to prevent settling and shall be complete with cast iron covers. Covers shall have "WATER" cast into the top for all water mains. The actuating nuts for deeper valves shall be extended to come up to 4-foot depth below finished grade.

Care shall be taken while constructing valve boxes to ensure that valve stems are vertical and the cast iron box has been placed over the stem with base bearing on compacted fill and top flush with final grade. Boxes shall have sufficient bracing to maintain alignment during backfilling. CONTRACTOR shall remove any sand or undesirable fill from valve box prior to final inspection.

All valve boxes shall be equipped with concrete collar.

## 15.6 Air Release Valves

Air Release Valves shall be manufactured to meet or exceed the requirements of AWWA C512 as appropriate, latest revision, and in accordance with the following SPECIFICATIONS:

The air release valves for use in water mains shall be installed as shown on the STANDARD DETAILS. Valves used for 6 inch water lines and larger shall have a cast-iron body or bronze body, cover and baffle, stainless steel float, bronze water diffuser, Buna-N or Viton seat and stainless-steel trim. Valves used on water lines smaller than six inches shall have a cast iron body with a stainless-steel float and trim, Buna-N valve with a stainless steel seat. Valves shall be provided with a vacuum check to prevent air from re-entering the line. The fittings shall be threaded (NPT).

## 15.7 Hydrants

15.7.1 Material: Hydrants shall have a 5-1/4 inch valve opening and shall comply with AWWA Standard C502 for hydrants for water works service, unless in conflict with MANUAL, in which case this MANUAL shall apply. Each hydrant shall have 6-inch mechanical joint ends with harnessing lugs ("dog ears") and shall open by turning to the left (counter-clockwise). Hydrant shall be of ample length for 3-1/2 foot depth of bury. It shall be provided with two 2-1/2 inch hose nozzles and one 5 1/4 inch pumper nozzle, all having National Standard hose threads. Nozzles shall have caps attached by chains. Operating nuts shall be AWWA Standard (pentagonal, measuring 1-1/2 inch point to flat). Hydrants shall be equipped with "O-Ring" packing.

15.7.2 Painting: All iron parts of the hydrant both inside and outside shall be painted, in accordance with AWWA C502. All inside surfaces and the outside surfaces below the ground line shall be coated with asphalt varnish. They shall be covered with the two coats, the first having dried thoroughly before the second is applied

The outside of the hydrant above the furnished ground line shall be thoroughly cleaned and thereafter painted with one coat of paint of a durable composition.

15.7.3 Construction Details: Hydrants shall be plumb and shall be set so that the lowest hose connection is, at least, eighteen (18) inches above the surrounding finished grade. All hydrants shall be inspected in the field upon delivery to the job to insure proper operation before installation. The resetting of existing hydrants and moving and reconnecting of existing hydrants shall be handled in a manner similar to a new-installation. Hydrant shall be constructed in accordance with the STANDARD DETAILS.

15.7.4 Location: Hydrants shall be located in the general location as shown on the DRAWINGS. All hydrants shall be located no less than five (5) and no more than ten (10) feet from the

edge of pavement of the adjacent roadway and no less than five (5) feet from any physical feature which may obstruct access or view of any hydrant, unless otherwise approved by the applicable county and UTILITY

## **DIVISION 4**

### **STANDARD DETAILS**

<b><u>Figure No.</u></b>	<b><u>Title</u></b>
1	Bore & Jack Detail Casing
2	Pavement Crossing
3	Standard Roadway Open-Cut Detail
4	Utility Separation Details
5	Typical Conflict Resolution by Deflection or Fittings
6	Restrained Joint Detail
7	Service Connection
7A	Typical 1.5 to 2 Inch Water Service
7B	Standard Meter Box and lid – 1 inch meter and smaller
8	Tapping Sleeve (1 of 2)
9	Tapping Sleeve (2 of 2)
10	Gate Valve and Extension
11	Hydrant Detail
12	Blow-off Detail for Hydropneumatic Tanks
12A	Standard Automatic Flushing Device
13	Air Release Valve Detail
14	Trench Detail
15	Guard Post Detail
16	Typical Thrust Block Detail
17	Reduce Pressure Backflow Preventer
18	Reduced Pressure Backflow Device Detail, 2 inch Services and Smaller
19	Service Connections for Compound Meters and Backflow Preventer Assembly 3", 4", 5", 8" and 10"
20	Typical Water System Layout With Gravity Sewer in the Cul-de-sac
20A	Typical Water System Layout Without Gravity Sewer in the Cul-de-sac
21	8" Well Detail
22	Well House Foundation
23	Well Piping Details
23A	Satellite Well Piping details
24	Chemical Details
25	Well w/ Tank Piping Details
26	Air Piping & Tank Piping Detail – McDonnell & Miller Layout
26A	Air Piping & Tank Piping Detail – Whitewater Layout
27	Hydropneumatic Tank
28	Hydropneumatic Tank Details for Standard Replacement
29	Hydropneumatic Tank Details for Standard Replacement 2
30	Well House Framing Details
31	Well House Exterior Details
32	Well House Electrical Layout
32A	Typical Well House Wiring Diagram
33	Three Phase Panel Layout
34	Single Phase Panel Layout
35	Typical Satellite Well Electrical Panel
36	Typical Satellite Well Electrical Panel Cover

**DIVISION 5**  
**LIST OF MATERIALS AND**  
**APPROVED MANUFACTURERS**

## Division 5

### Section 1

#### North Carolina

##### 1.1 Well Sites

- 1.1 Grassing: Centipede grass seed mixed with “Contractus”.
- 1.2 Graveling: 4” thick, compacted, crush and run gravel.

##### 1.2 Pumps and Motors

- 1.2.1 Submersible Motors: Motors shall be manufactured by Franklin or Centri-pro and of the highest psi thrust bearing available. Any other manufacturer must be approved by UTILITY.
- 1.2.2 Submersible Pumps
  - 1.2.2.1 Goulds or Grundfos are acceptable; design shall be for the most efficiency.
  - 1.2.2.2 1.5”, 2” & 3” sizes acceptable, larger sizes may be approved as required (Drop Pipe).
  - 1.2.2.3 Strataflo, series 300, full port, NPT, spring check valve. Two (2) are required if setting is 300 plus feet deep.
- 1.2.3 Booster Pumps and Motors
  - 1.2.3.1 Booster pumps shall be designed by, or approved, by Utility to meet 12hr demand with submersible pumping and storage capacity. The pumps and the tank(s) shall also meet Peak demand. All pumps shall be approved by Utility.
  - 1.2.3.2 Booster Pumps of the series specified and shall be manufactured by either:
    - Goulds  
Low pressure up to 60psi, Centrifugal, Series “S”, “LH”, “M” or “L” close coupled, 230VAC, single or 3 phase, depending on circumstances.  
High pressure over 60psi, Multi-stage, Series “SSV”, configuration SVB, SVD, or SVC, vertical , 230VAC, single or 3 phase, depending on circumstances.  
In certain instances, as specified by the Utility, Variable speed pumps may be used and would be of the “Aquavar” series.
    - Grundfos



Low pressure up to 60psi, Centrifugal, Series “SR” or SF, close coupled, 230VAC, single or 3 phase, depending on circumstances.

High pressure over 60psi, Multi-stage, Series “CR”, “CRI” or CRN with a flanged inlet and outlet configuration, 230VAC, single or 3 phase, depending on circumstances.

In certain instances, as specified by the Utility, Variable speed pumps may be used and would be of the “BoosterpaQ” system.

- 1.2.4 Control: Only dual pumps with alternating, lead-lag, bypass and step interlock and all necessary controls shall be installed.
- 1.2.5 Air release shall be Watts, 1/4” bronze model FV -4M1(Dayton 4A821).
- 1.2.6 Swing check valve (horizontal piping only): Nibco, Bronze, Industrial, NPT, WOG minimum 200psi.  
Spring check valve (vertical piping only): Strataflo, series 300 spring.
- 1.2.7 Gate valve: Nibco, Bronze, Industrial, short stem, NPT, WOG 300psi, series T-133.
- 1.2.8 Ball valve (1/4”): Apollo, Bronze, NPT, series 70-100, WOG 600psi.  
Gauge: liquid filled 100psi w 1/4” NPT stem - Campbell PG11T-1.  
liquid filled 200psi w 1/4” NPT stem – Campbell PG13T-L

### 1.3 Plumbing

#### 1.3.1 Valve Bank

1.3.1.1 Above ground pipe: galvanized steel, cast Brass or Stainless.

1.3.1.2 Below ground pipe: PVC, , Ductile Iron, Brass or Stainless.

1.3.1.3 Water Meter: Sensus Omni or Hersey MVR Pulsar Flow provided by UITLETY.

1.3.1.4 Wye Strainer: Watts, bronze, series 777 or 77s, WOG 400psi

Ball valve (1” up): Apollo series 77-100, Bronze, threaded , Full Port with WOG of 600psi.

Pipe (above ground): galvanized, brass or stainless steel with braided poly pipe to Strainer.

1.3.1.5 Rubatex insulation only.

1.3.1.6 1/4” ball valve: Apollo, bronze, series 70-100, WOG 600psi.

1.3.1.7 Gauges: liquid filled 100psi w 1/4” NPT stem - Campbell PG11T-1.

liquid filled 200psi w 1/4” NPT stem – Campbell PG13T-L.

1.3.1.8 Swing check valves (1” up): Nibco, Lead Free bronze, threaded with WOG 200psi.

Ball valves (1” up): Apollo series 77-100, Bronze, threaded , Full Port with

WOG of 600psi.

Gate valves: Nibco, Lead Free Bronze, non-rising stem, Series T-113 with WOG 300 psi

1.3.1.9 Pressure Switch: Allen Bradley, Model 836T-T253J.

Ball Valves: Apollo, bronze, series 70-100, WOG 600psi.

1.3.1.10 Hose bib:

Threaded: Nibco, Lead Free, bronze, NPT with WOG 200psi.

Non-threaded: Nibco, industrial, bronze, NPT with WOG 200psi.

1.3.1.11 Eyewash: Guardian, model G5026.

1.3.1.12 Distribution Pressure Relief Valve – 2 inch Kunkle Model 0020-H01-MG

Factory set at 100 psig – all bronze

1.3.2 Hydro Pneumatic tank

1.3.2.1 Dresser sleeve shall be MJ, cast type such as manufactured by UFCO or equal.

1.3.2.2 MJ valve: valves shall comply with AWWA C-500 and be iron body, parallel seat type, bronze fitted with resilient rubber coated wedge. Model # Kennedy 15TIX, Mueller A2360 or equivalent.

Valve Box: cast iron, adjustable screw type Part #.

Valve Box Ring: Brooks 24" valve collar.

1.3.2.3 MJ valve: valves shall comply with AWWA C-500 and be iron body, parallel seat type, bronze fitted with resilient rubber coated wedge. Model # Kennedy 15TIX, Mueller A2360 or equivalent.

1.3.2.4 Valve Box: cast iron, adjustable screw type, such as manufactured by UFCO or equal.

Valve Box Ring: Brooks 24" valve collar.

1.3.3 Distribution line:

1.3.3.1 SDR 21, Class 200 PVC, acceptable within subdivision up to 2" unless otherwise directed by UTILITY.

1.3.3.2 DR 14, C900 PVC, acceptable within subdivision, state, county or federal roads, under culverts and under creeks (when cased).

1.3.3.3 Class 50, Ductile Iron, minimum pressure rating 200psi, acceptable within subdivision, state, county or federal roads, under culverts and under creeks (when cased).

1.3.3.4 HDPE pipe of the specified size and pressure rating of not less than 200psi, shall be used under wetlands or stream crossings. Proper size and type fittings shall be installed. Once the pipe is installed, if direct bored, it shall have a waiting period of 7 days, to allow for shrinkage before tying on to other pipe.

- 1.3.4 Restraint Fittings
  - 1.3.4.1 MJ fittings, where the restraining system is built in, such as AquaGrip, shall be acceptable on all types of pipe without further blocking.
  - 1.3.4.2 Megalug restraint collars systems shall not be allowed on SDR 21, Class 200 PVC. Types with minimum of 6 lugs, are acceptable on all other pipes listed under (5) above.
- 1.3.5 Relief Valve: bronze, NPT, ASTM and Boiler rated, steam rated, valve, set at the tested or approved tank pressure, Kunkle Valve, Model 6010eem01-km0(xxx) (psi).
- 1.3.6 Vacuum Breaker: Strataflo, series 300, inverted spring check valve with mushroom vent.
- 1.3.7 Locking Ball Valve: Apollo ball valve, model 75 -105 with 600 WOG rating and a four position locking device. All Valves with be clock-wise closed and counter clock-wise open
- 1.3.8 Air Compressor
  - 1.3.8.1 Whitewater, Model 1/6hp, 120VAC.
  - 1.3.8.2 Probes and pressure switch Included with (1).
- 1.3.9 Chemical Barrels: Pulsafeeder chemical barrel (55 gal).

## **1.4 Distribution mains**

- 1.4.1 Mains
  - 1.4.1.1 same as Distribution Line.
  - 1.4.1.2 same as Restraint Fittings.
  - 1.4.1.3 Other Fittings: Tees, bend, etc. MJ cast (Mueller or equal) or compression (as made by “One Bolt, Inc.”).
  - 1.4.1.4 MJ Gate Valves (Square nut): Kennedy 15TIX, Mueller A-2360 or equivalent.
  - 1.4.1.5 Valve Box: cast iron, adjustable screw type, such as manufactured by UFCO or equal.
  - 1.4.1.6 Valve Box Ring: Brooks 24” valve collar.
  - 1.4.1.7 Air Relief Valve: automatic blow-off – For 6 inch and large water lines, the air relief valve shall be APCO #200, Crispin PL 20 (2inch) or equivalent. For water lines smaller than 6 inch the air relief valve shall be the Crispin AR10 (1 inch), APCO #50 (1 inch), or equivalent.
  - 1.4.1.8 Mains: Last 400’ on cul-de-sacs – minimum size 4”.

## 1.4.2 Services

1.4.2.1 Meter Box: NDS D1200 meter box with hinge lid.

1.4.2.2 Meter setter: Ford Model VHH-72-7W or Mueller 1404-2 Yoke or

1.4.2.3 Strap Saddles: Bronze, double strap made by Mueller, Ford or Equal.

1.4.2.4 Compression Fittings: Mueller, Ford or equal.

1.4.2.5 Chaseways: schedule 40, PVC, electrical conduit or plumbing pipe.

1.4.2.6 Meters: Provided by UTILITY.

1.4.2.7 All service lines shall be ¾" 1", 1-1/2" or 2" blue polyethylene tubing conforming to specifications in AWWA C800 and AWWA . One and one-half inch (1-1/2") and larger shall be sized in accordance with the Iron Pipe Sizing Standard (IPS); ¾ " and 1" shall be the Copper Tube Sizing Standard (CTS)

## 1.4.3 Backflow and Cross Connection

1.4.3.1 Backflow Prevention Device:

Severe Hazard: Bronze RPZ – Cla-Val-RP2, Watts Series 009QT, Wilkins

WK975XL-075, Febco 825Y (D), Conbraco 400, or approved equal

Moderate Hazard: Bronze, Double Check Valve Assembly, part # 40-104-997

## 1.4.4 Hydrants

1.4.4.1 Kennedy K81-D2 5 1/4", Mueller Centurion A421 5 1/4", or utility-approved equal.

## 1.5 Water Treatment

### 1.5.1 Chemical Equipment.

1.5.1.1 Chemical Pump: Pulsafeeder, model LE Series of appropriate pressure and flow design requirements, or as specified by UTILITY.

14gpd @ 100psi: LEK3SA-VHC-xxx

24gpd @ 100psi: LE14SA-VHC-xxx

6gpd @ 150psi: LE2SA-VHC-xxx

22gpd @ 150psi: LEK34SA-VHC-xxx

1.5.1.2 Chemical Vat: NSF Approved- Snyder or approved equivalent

1.5.1.3 Safety Components

Flow Switch, Low Flow (below 15gpm): ITT, McDonnell & Miller Model FS7-4.

Flow Switch, Full Flow (over 15gpm): ITT, McDonnell & Miller Model FS4-3.

## 1.6 Tanks

### 1.6.1 Hydro Pneumatic Tanks

1.6.1.1 Tank shall be National Board stamped ASME approved, as manufactured by RECO USA or Ramco Tank Manufacturers. Other tank manufacturers to submit plans for approval to UTILITY before construction on the tank begin.

1.6.1.2 Pedestals shall be poured with 12” dip for tank and a minimum of 3/8” thick rubber shall be installed between the tank and the pedestal.

#### 1.6.2 Ground Storage Tanks

1.6.2.1 Probes shall be manufactured by WARRICK CONTROLS and of the configuration specified by Utility.

### 1.7 Well House

#### 1.7.1 Building

1.7.1.1 Door: 36” minimum single door, steel of (min) 16 Gauge, painted with Epoxy Paint or a semi solid or solid fiberglass door.

1.7.1.2 Automatic Foundation Vents: 8”x16”.  
Closing Vents: 8”x 16”, part #.

### 1.8 Electrical

#### 1.8.1 Panels

1.8.1.1 Panel 230VAC, ITE, with copper busway.  
Nema 4X Inside and Outside  
Part Number Single Phase  
Part Number Three Phase

#### 1.8.2 Magnetic Starters

1.8.2.1 Starter: Allen Bradley, Nema 3R, , three pole with 120VAC coil.

1.8.2.2 Timer: Intermatic Model FF5M spring wound 5-minute timer (also works for hand switch).

1.8.2.3 Auxiliary Contacts: Two Normally open required

1.8.2.4 Thermal Overloads: Allen Bradley – series “J”.

#### 1.8.3 Pressure Switch: Allen Bradley – 835T-T253J or Square D

#### 1.8.4 Indicating Controls

1.8.4.1 Elapsed Time Meter: Vender-Root 7795.

1.8.4.2 Impulse Counter: Durant 6-Y-41345.

1.8.5 Telemetry / Radio Controls

1.8.5.1 Telemetry: provided by UTILITY.

1.8.5.2 Radio Control: provided by UTILITY.

1.8.6 Air Compressor: Whitewater, Model 1/6hp, 120vac, Model # 1HAB-44-M100X 115 volt 1/6HP 0.12 KW 60 Hz, or McDonnell & Miller Tank Level Controller.

1.8.7 Heating

1.8.7.1 Base Board Heater:

4': 1,000-watt, 240 volts AC, part # Dayton 3UG84D.

1.8.7.2 Remote Thermostat: White-Rodgers, Model #2B61-186.

1.8.8 Auto-Off Timers: Intermatic FF Series, Commercial Series.

## **APPENDIX I – CLAIMS FORM**

# Public Works Commission

## Fayetteville, North Carolina

### PROPERTY DAMAGE CLAIM FORM

This form is provided as a means for an individual to seek reimbursement from the Public Works Commission of the City of Fayetteville, North Carolina for property damage of an individual or guardian filing this claim. The Fayetteville Public Works Commission is governed by the General Statutes of North Carolina.

Please read and follow instructions below:

1. Fill in all parts of the form. If there are any section(s) that do not apply to your claim, please indicate by placing N/A in the space.
2. Cost estimates must be bona fide estimates for repair or replacement of all damage items listed on this form.
3. Food items should be listed individually on a separate paper and a cost or replacement cost be provided.
4. Total the combined items at the end of the list and transfer that total and all other totals to the Amount of Claim line on the requisition page.
5. Original cost estimates, pictures, or documents should be attached to the completed claim form. (No photocopies will be accepted.)
6. Sign and date the claim form.
7. Return completed form to: Water Resources Engineering Department/Annex  
C/O Public Works Commission  
P.O. Box 1089  
Fayetteville, N.C. 28302-1089

Last Name: \_\_\_\_\_ First Name: \_\_\_\_\_

Business Name (if applicable): \_\_\_\_\_

Street: \_\_\_\_\_ City: \_\_\_\_\_ State: \_\_\_\_\_ Zip: \_\_\_\_\_

Home Telephone #: ( ) \_\_\_\_\_ Work Telephone #: ( ) \_\_\_\_\_

Email Address (if you would like to be contacted by email): \_\_\_\_\_

Date of Incident: \_\_\_\_\_ Time of Incident: \_\_\_\_\_

Location of Incident: \_\_\_\_\_

List and describe all damaged property: (Attach additional sheets if necessary)

---

---

---

---

---



---

Owner: *(If different than claimant)*

Name: \_\_\_\_\_ Daytime Telephone #: ( ) \_\_\_\_\_

Address: \_\_\_\_\_

---

If this property is covered by Insurance Company, list information below:

Insurance Agent: \_\_\_\_\_ Telephone #: ( ) \_\_\_\_\_

Insurance Company: \_\_\_\_\_

Address: \_\_\_\_\_ State: \_\_\_\_\_ Zip Code: \_\_\_\_\_

Policy Number: \_\_\_\_\_ Expiration Date: \_\_\_\_\_

---

**VEHICLE DESCRIPTION:**

Make and Model: \_\_\_\_\_ Year: \_\_\_\_\_

Police Report Number (If available): \_\_\_\_\_

---

Give a brief description of what happened: *(Attach additional sheets if necessary)*

\_\_\_\_\_  
\_\_\_\_\_  
\_\_\_\_\_  
\_\_\_\_\_

---

Witness(s):

Name: \_\_\_\_\_ Phone: ( ) \_\_\_\_\_

Address: \_\_\_\_\_

---

**AMOUNT OF CLAIM: \$** \_\_\_\_\_

I acknowledge that all statements provided in this Claim for Damage form is true and that I have signed and dated this statement for authenticity of documents and information.

Claimant Signature: \_\_\_\_\_

Date: \_\_\_\_\_

---

Any questions regarding this claim should be directed to the Water Resources Engineering at (910) 223-4730. The Public Works Commission reserves the right to question any cost estimate(s) prior to acceptance of a claim.

**BEFORE MAILING MAKE SURE ALL ESTIMATES AND/OR LISTS ARE ATTACHED**

# **APPENDIX J – LATERAL RELOCATOIN RELEASE FORM**

## Lateral Relocation Release Form

Project: \_\_\_\_\_

Contractor: \_\_\_\_\_

I, \_\_\_\_\_ property owner of \_\_\_\_\_

(address), requested my proposed sewer/water lateral location be relocated from sta.

\_\_\_\_\_ to sta. \_\_\_\_\_. I \_\_\_\_\_ release and hold harmless,

\_\_\_\_\_ (contractor), The City of Fayetteville, the Public Works Commission,

and \_\_\_\_\_ (engineering firm) any and all liability stemming from the above

agreement.

\_\_\_\_\_

Property Owner

\_\_\_\_\_

Date

\_\_\_\_\_

Contractor Representative

\_\_\_\_\_

Date

\_\_\_\_\_

Project Coordinator

\_\_\_\_\_

Date

## **APPENDIX K – WATER PERMIT**



EVELYN O. SHAW, COMMISSIONER  
RONNA ROWE GARRETT, COMMISSIONER  
DONALD L. PORTER, COMMISSIONER  
CHRISTOPHER DAVIS, COMMISSIONER  
MARION J NOLAND, INTERIM CEO/GENERAL MANAGER

FAYETTEVILLE PUBLIC WORKS COMMISSION  
955 OLD WILMINGTON RD  
P.O. BOX 1089  
FAYETTEVILLE, NORTH CAROLINA 28302-1089  
TELEPHONE (910) 483-1401  
WWW.FAYPWC.COM

July 25, 2023

John P. Allen  
Fayetteville Public Works Commission  
955 Old Wilmington Road  
Fayetteville, NC 28301

Re Engineering Plans and Specifications Approval  
Water Supply System Extension  
Fayetteville PWC Water System to serve  
**Fayetteville Annexation Phase  
V Project XI Construction  
Area 25 Lake Rim Estates &  
Oak Meadow Subdivision**  
Cumberland County  
**Permit # PWC2023-W024**

Dear Mr. Allen,

Enclosed please find one copy of the approved "Application for Water Supply System Extension" together with one copy of the referenced engineering plans bearing the Fayetteville Public Works Commission (PWC) stamp of approval and signature of the signing Authority for the referenced project. The project plans and PWC specifications referenced in the submitted permit application are approved insofar as the protection of public health is concerned as provided in the rules, standards and criteria adopted under the authority of Chapter 130A-317 of the General Statutes. The official copies of engineering plans have been stamped with the serial number of this application PWC Permit Number **PWC2023-W024** on **July 25, 2023**. Only such plans and specifications are included in this approval and any erasures, additions, or alterations of the proposed improvements except those permitted will make such approval null and void.

Engineering plans and specifications prepared by John P. Allen, call for the construction of approximately **294 LF of 2 inch water, 226 LF of 6 inch water, 1,069 LF of 8 inch water, and 6,459 LF of 12 inch water.** for **Fayetteville Annexation Phase V Project XI Construction Area 25 Lake Rim Estates & Oak Meadow Subdivision located in Cumberland County.** This permit is valid for 24 months from the date of issuance, or until revoked, and shall be subject to the conditions and limitations as specified herein. The permit may be extended in accordance with PWC's Delegated Sewer Collection System and Water Distribution System Permit Program authorized by the City of Fayetteville's Code of Ordinances. The enclosed "Authorization to Construct" certificate shall be posted at the primary entrance of the job site throughout construction of this project.

This permit is not transferable. In the event there is a change of Applicant, a formal permit application shall be submitted to PWC accompanied by documentation from the parties involved, and other supporting materials as may be appropriate.

**BUILDING COMMUNITY CONNECTIONS SINCE 1905**

AN EQUAL EMPLOYMENT OPPORTUNITY EMPLOYER

This permit shall become voidable unless the water distribution facilities are constructed in accordance with the conditions of this permit, PWC's Design Manual, applicable State rules and regulations, and other supporting material, unless specifically mentioned herein.

Failure to abide by the conditions and limitations contained in this permit; NCAC 15A Subchapter 18C "Rules Governing Public Water Systems"; and other supporting materials may subject the Applicant to complete construction of additional or replacement water supply system facilities, referral of the North Carolina-licensed Professional Engineer to the licensing board, and/or an enforcement action by PWC, in accordance with PWC's Delegated Sewer Collection System and Water Distribution System Permit Program authorized by the City of Fayetteville's Code of Ordinances,

In the event that the water supply system facilities fail to perform satisfactorily, including the creation of nuisance conditions, the Applicant shall take immediate corrective action, including those as may be required by PWC, such as the construction of additional or replacement facilities.

The issuance of this permit shall not exempt the Applicant from complying with any and all statutes, rules, regulations, or ordinances that may be imposed by PWC, any other Federal, State, or Local government agencies which have jurisdiction or obtaining other permits which may be required by PWC or any other Federal, State, or Local government agencies.

Approval must be secured from PWC before any construction or installation if:

- Deviation from the approved engineering plans and specifications is necessary; or
- There are changes in site conditions affecting capacity, hydraulic conditions, operating units, the function of the water treatment processes, the quality of water to be delivered, or conditions imposed by the Public Works Commission in any approval letters.

After-construction requests are discouraged and may not be approved, thus requiring replacement or repair prior to certification and activation.

Upon completion of the construction and in accordance with Rule .0303, the applicant shall submit a certification statement signed and sealed by a registered professional engineer stating that construction was completed in accordance with approved engineering plans and specifications, including any provisions stipulated in this letter. Prior to Final Approval, PWC shall submit a signed certification stating that the requirements in 15A NCAC 18C .0307 (d) and (e) have been satisfied and if applicable, a completed application for an operating permit and fee. Once the certification statements and operating permit application and fee, if applicable, are received and determined adequate, the PWC will grant Final Approval in accordance with Rule .0309 (a). Therefore, no construction, alteration, or expansion of the water system shall be placed into service until the Public Works Commission has issued Final Approval.

A complete Engineering Certification is one where the form is fully executed, and the supporting documents are provided as applicable. Supporting documentation shall include one copy of the project construction record drawings (plan and profile views of water mains) of the water supply system extension. Final record drawings should be clear on the plans and are defined as the design drawings that are marked up or annotated with after construction information and show required buffers, separation distances, material changes, etc.

Any portion of the water supply system extension placed into service prior to completion of this Engineer's Certification shall be considered a violation of the permit and shall subject the Applicant to appropriate enforcement actions.

**Prior to receiving any water meters for use on the above referenced project, PWC must have received and approved:**

- The Engineering Certification from the Design Engineer
- Record Drawings
- The PWC Project Coordinator's inspection report
- The Applicant's "Statement of Total Project Cost" summary.

**Please allow approximately thirty (30) calendar days for PWC to process the above documentation.**

If any parts, requirements, or limitations contained in this permit are unacceptable, an adjudicatory hearing shall be requested within 30 calendar days following receipt of this permit. This request must be in the form of a written petition, in accordance with PWC's Delegated Sewer Collection System and Water Distribution System Permit Program authorized by the City of Fayetteville's Code of Ordinances. This permit shall be final and binding, unless such petition has been properly filed.

If you have any questions regarding this matter, please contact Mr. John Allen at (910) 223-4734.

Sincerely,  
**PUBLIC WORKS COMMISSION**

JOHN P. ALLEN

[JOHN P. ALLEN \(Jul 26, 2023 08:34 EDT\)](#)

John P. Allen, P.E.

Interim Manager

Water Resources Engineering

Enclosures: DWS-15380

cc: Jeffrey B. Reitzel, P.E., PLS

Project file

## **APPENDIX L – SEWER PERMIT**





WADE R. FOWLER, JR., COMMISSIONER  
EVELYN O. SHAW, COMMISSIONER  
RONNA ROWE GARRETT, COMMISSIONER  
DONALD L. PORTER, COMMISSIONER  
MARION J NOLAND, INTERIM CEO/GENERAL MANAGER

FAYETTEVILLE PUBLIC WORKS COMMISSION  
955 OLD WILMINGTON RD  
P.O. BOX 1089  
FAYETTEVILLE, NORTH CAROLINA 28302-1089  
TELEPHONE (910) 483-1401  
WWW.FAYPWC.COM

July 25, 2023

John P. Allen  
Fayetteville Public Works Commission  
955 Old Wilmington Road  
Fayetteville, NC 28301

Re: Engineering Plans and Specifications Approval  
Wastewater Collection System Extension  
**Fayetteville Annexation Phase V Project XI**  
**Construction Area 25 Lake Rim Estates & Oak**  
**Meadow Subdivision**  
Cumberland County  
**Permit # PWC2023-S024**

Dear Mr. Allen,

In accordance with your application, the Fayetteville Public Works Commission (PWC), on behalf of the State of NC Environmental Management Commission, has assigned Permit Number PWC2023-S024, effective July 25, 2023, to the addressee for the construction of the subject wastewater collection system extension as described in the application for **Fayetteville Annexation Phase V Project XI Construction Area 25 Lake Rim Estates & Oak Meadow Subdivision**.

This permit is valid for 24 months from the date of issuance, or until revoked, and shall be subject to the conditions and limitations as specified below:

1. The enclosed Authorization to Construct shall be posted at the primary entrance of the job site throughout construction.
2. The project shall be constructed in accordance with the approved application, engineering plans, and the PWC standards, specifications, PWC's Delegated Sewer Collection System and Water Distribution System Permit Program authorized by the City of Fayetteville's Code of Ordinances on behalf of the State of NC Environmental Management Commission and other applicable Laws, Rules, and Regulations. Permission is hereby granted to 4,384 LF of 12 inch CL 50 DIP, 9,477 of 8 inch SDR 26 PVC, 10,722 of 8 inch CL 50 DIP, and 87,480 GPD of collected domestic wastewater into the PWC/Fayetteville Collection System (WQCS 00007), pursuant to the application received and in conformity with 15A NCAC 02T, PWC's Design Manual, the State's Minimum Design Criteria as applicable, and any other supporting data subsequently filed and approved by PWC.
3. The wastewater collected by this system shall be treated in the PWC Rockfish Wastewater Treatment Facility Permit NC0050105, prior to being discharged into the receiving stream.
4. **This permit is not transferable.** In the event there is a change of Applicant, a formal permit application shall be submitted to PWC accompanied by documentation from the parties involved, and other

**BUILDING COMMUNITY CONNECTIONS SINCE 1905**

AN EQUAL EMPLOYMENT OPPORTUNITY EMPLOYER

supporting materials as may be appropriate.

5. This permit shall become voidable unless the wastewater collection facilities are constructed in accordance with the conditions of this permit, PWC's Design Manual, applicable State rules and regulations, and other supporting material, unless specifically mentioned herein.
6. This permit shall be effective only with respect to the nature and volume of wastes described in the approved application and other supporting data.
7. Construction of the gravity sewers, pump stations, and force mains shall be scheduled so as not to interrupt service to the existing utilities nor result in an overflow or bypass discharge of wastewater to the surface waters of the State.

Upon completion of construction and prior to operation of these permitted facilities, the completed Engineering Certification form shall be submitted with the required supporting documents to the address provided on the form. Any wastewater flow made tributary to the wastewater collection system extension prior to completion of this Engineer's Certification shall be considered a violation of the permit and shall subject the Applicant to appropriate enforcement actions.

A complete certification is one where the form is fully executed, and the supporting documents are provided as applicable. Supporting documentation shall include the following:

- a. One copy of the project construction record drawings (plan and profile views of sewer lines and force mains) of the wastewater collection system extension. Final record drawings should be clear on the plans and are defined as the design drawings that are marked up or annotated with after construction information and show required buffers, separation distances, material changes, etc.
- b. One copy of the supporting applicable pump station design calculations including pipe and pump sizing, velocity, pump cycle times, and level control settings, pump station buoyancy, wet well storage, surge protection, detention time in the wet well, and force main, ability to flush low points in force mains with a pump cycle, and downstream sewer capacity analysis. If a portable power source or pump is dedicated to multiple stations, an evaluation of all the pump stations' storage capacities and the rotation schedule of the portable power source or pump, including travel timeframes, shall be provided.
- c. Changes to the project that do not result in non-compliance with this permit, regulations, or the Minimum Design Criteria should be clearly identified on the record drawings, on the certification in the space provided, or in written summary form.

Prior to Certification (Final or Partial): Permit modifications are required for any changes resulting in non-compliance with this permit (including pipe length increases of 10% or greater, increased flow, pump station design capacity design increases of 5% or greater and increases in the number/type of connections), regulations, or the Minimum Design Criteria. Requested modifications or variances to the Minimum Design Criteria must be reviewed by the State and will be reviewed on a case-by-case basis and each on its own merit. Please note that variances to the Minimum Design Criteria should be requested and approved by the State during the permitting process prior to construction. After-construction requests are discouraged by the State and may not be approved, thus requiring replacement or repair prior to certification and activation.

8. Gravity sewers installed greater than ten percent below the minimum required slope per the State's Gravity Sewer Minimum Design Criteria shall not be acceptable and shall not be certified until corrected. If there is an unforeseen obstacle in the field where all viable solutions have been examined, a slope variance can be requested from the State with appropriate supporting documentation. This shall be done through a permit modification with fee submitted to the State. Such variance requests will be evaluated

on a case-by-case basis. Resolution of such request shall be evident prior to completing and submitting the construction certification.

9. Failure to abide by the conditions and limitations contained in this permit; 15A NCAC 2T; the Division's Gravity Sewer Design Criteria adopted February 12, 1996 as applicable; the Division's Minimum Design Criteria for the Fast-Track Permitting of Pump Station and Force Mains adopted June 1, 2000 as applicable; and other supporting materials may subject the Applicant to an enforcement action by PWC, in accordance with PWC's Delegated Sewer Collection System and Water Distribution System Permit Program authorized by the City of Fayetteville's Code of Ordinances, construction of additional or replacement wastewater collection facilities, and/or referral of the North Carolina-licensed Professional Engineer to the licensing board.
10. In the event that the wastewater collection facilities fail to perform satisfactorily, including the creation of nuisance conditions, the Applicant shall take immediate corrective action, including those as may be required by PWC, such as the construction of additional or replacement facilities.
11. The issuance of this permit shall not exempt the Applicant from complying with any and all statutes, rules, regulations, or ordinances that may be imposed by PWC, any other Federal, State, or Local government agencies which have jurisdiction or obtaining other permits which may be required by PWC or any other Federal, State, or Local government agencies.
12. **Prior to receiving any water meters for use on the above referenced project, PWC must have received and approved:**
  - The Engineering Certification from the Design Engineer**
  - Record Drawings**
  - The PWC Project Coordinator's inspection report**
  - The Applicant's "Statement of Total Project Cost" summary.**

**Please allow approximately thirty (30) calendar days for PWC to process the above documentation.**

If any parts, requirements, or limitations contained in this permit are unacceptable, an adjudicatory hearing shall be requested within 30 calendar days following receipt of this permit. This request must be in the form of a written petition, in accordance with PWC's Delegated Sewer Collection System and Water Distribution System Permit Program authorized by the City of Fayetteville's Code of Ordinances. This permit shall be final and binding, unless such petition has been properly filed.

We are enclosing one (1) set of approved plans for construction. The project must comply with all permit requirements as contained herein, all requirements found in the PWC Design Manual and all regulations related to the Environmental Management Commission.

If you have any questions regarding this matter, please contact Mr. John Allen at (910) 223-4734.

Sincerely,  
PUBLIC WORKS COMMISSION

JOHN P. ALLEN

JOHN P. ALLEN (Jul 26, 2023 08:33 EDT)

John P. Allen, P.E.  
Interim Manager  
Water Resources Engineering

Enclosures: DWS-15380

cc: Jeffrey B. Reitzel, P.E., PLS.

Project File